

Site Preparation Guide hp Integrity Superdome and hp 9000 Superdome

Fifth Edition



Manufacturing Part Number: A5201-96046

February 2005

USA

Legal Notices

© Copyright 2005 Hewlett-Packard Development Company, L.P.

The information contained herein is subject to change without notice.

The only warranties for HP products and services are set forth in the express warranty statements accompanying such products and services. Nothing herein should be construed as constituting an additional warranty. HP shall not be liable for technical or editorial errors or omissions contained herein.

1. Introduction

Basic System Building Blocks	3
--	---

2. Dimensions and Weights

Component Dimensions	10
Component Weights	11
Shipping Dimensions and Weights	12

3. Electrical Specifications

Grounding	14
Circuit Breaker	15
Power Options	16
Power Cords	17
System Power Requirements	26
Component Power Requirements	27
I/O Expansion Cabinet Power Requirements	28
I/O Expansion Cabinet Power Cords	29

4. Environmental Requirements

Temperature and Humidity Specifications	32
Power Dissipation	33
Acoustic Noise Specification	38
Air Flow	39

5. Facility Guidelines

Electrical and Environmental Guidelines	42
Electrical Factors	42
Environmental Elements	47
Site Guidelines	58
Facility Characteristics	58
Space Requirements	61

6. Pre-Installation Survey

Pre-Installation Survey Content	64
Typical Installation Schedule	65
Site Inspection	66
Delivery Survey	70

A. Templates

Equipment Footprint Templates	80
Computer Room Layout Plan	81

B. Configuration Guidelines

Configuration Guidelines	94
Memory Population	94

Contents

Cell Population 94
Partition Size 94
I/O Chassis Allocation 97
System Planner 98

Preface

Scope

This document is intended for viewing by hp service personel and its customers.

This document does not describe system software or partition configuration operations in any detail. For detailed information concerning those topics refer to the *hp System Partitions Guide* (5990-8170A).

Book Layout

This document contains the following chapters and appendices:

- Chapter 1, Introduction—Brief introduction to the hp Integrity Superdome
- Chapter 2, Dimensions and Weights—Necessary physical specifications of the servers
- Chapter 3, Electrical Specifications—Necessary electrical specifications of the servers
- Chapter 4, Environmental Requirements—Special requirements of the server
- Chapter 5, Facility Guidelines—Preparation of the customer's site before installation of the hp Integrity Superdome
- Chapter 6, Pre-Installation Survey—A helpful survey to be used prior to installation

In addition, the following appendices provide supplemental material.

- Appendix A, Templates—Useful document for planning customer installations
- Appendix B, Configuration Guidelines—Provides allowable configurations.

Revision History

Table 1 **Revisions**

Part Number	Edition	Summary of Changes
A5201-96018	First	Initial Release. September 2003
A5201-96022	Second	Released March, 2004. Includes updates for PA-8800, PA-RISC processor for hp9000 Superdome, plus numerous additions and corrections.
A5201-96027	Third	Released June, 2004. Includes updates for dual-core IPF processor for hp Integrity Superdome.
A5201-96032	Fourth	Released September, 2004. Added general corrections and updates.
A5201-96046	Fifth	Released February 2005, Added SRG section

1 Introduction

The Superdome family of high-end computers has two new members: hp Integrity Superdome and hp 9000 Superdome. Improvements over the Superdome predecessors include higher processor performance, increased local cell board memory bandwidth, and increased scalability. The hp Integrity Superdome uses the Itanium® 2 single- and dual-core processors, and the hp 9000 Superdome uses the dual-core PA-8800.

The biggest differences between hp Integrity Superdome servers or hp 9000 Superdome servers and earlier Superdome family products include (but are not limited to):

- Cell board design using either of the following processors:
 1. Itanium® 2 single- and dual-core for hp Integrity Superdome
 2. PA-8800 PA-RISC dual-core for hp 9000 Superdome
- Firmware packages.
 - Management Processor
 - CLU—clocks, I²C bus, and so on.
 - PM (Environmental monitors)
 - Core I/O (Console in I/O chassis)
 - System hp Integrity Superdome (IPF on the cell board)
 - System hp 9000 Superdome (PA on the cell board)
 - PDHC (SINC comes on the cell board)
 - Event dictionary (ED)
- 12-slot PCI-X I/O card cage
- 2-GB DIMMS
- Two optional support Management Stations
 - Windows-based hp Proliant ML350 G3 (PC-SMS)
 - HP-UX based hp Server rx2600 (HP-UX SMS)

The hp Integrity Superdome supports HP-UX 11.23 and Windows Server 2003, Datacenter.

The hp 9000 Superdome supports HP-UX 11.11.

Basic System Building Blocks

The basic system building blocks used to configure a system are as follows:

Figure 1-2 on page 5 illustrates a typical SD16 or SD32 installation.

Figure 1-3 on page 6 illustrates a typical SD64 installation.

Figure 1-4 on page 7 illustrates a typical SD64 and I/O expansion cabinet installation.

Server Cabinet

The server cabinet is the main building block. An SD64 comprises two server cabinets interconnected.

A single SD32 cabinet may contain up to eight cell boards (32 processors), four I/O card cages, four I/O fans, four system cooling fans, six bulk power supplies, and two PDCA. Figure 1-1 illustrates the location of these components.

A single SD16 cabinet may contain up to four cell boards (16 processors), four I/O card cages, five I/O fans, four system cooling fans, four bulk power supplies, and two PDCA. Additionally, to the above, two backplane power supplies provides N+1 for the SD16.

Figure 1-1 **Server Cabinet Components**

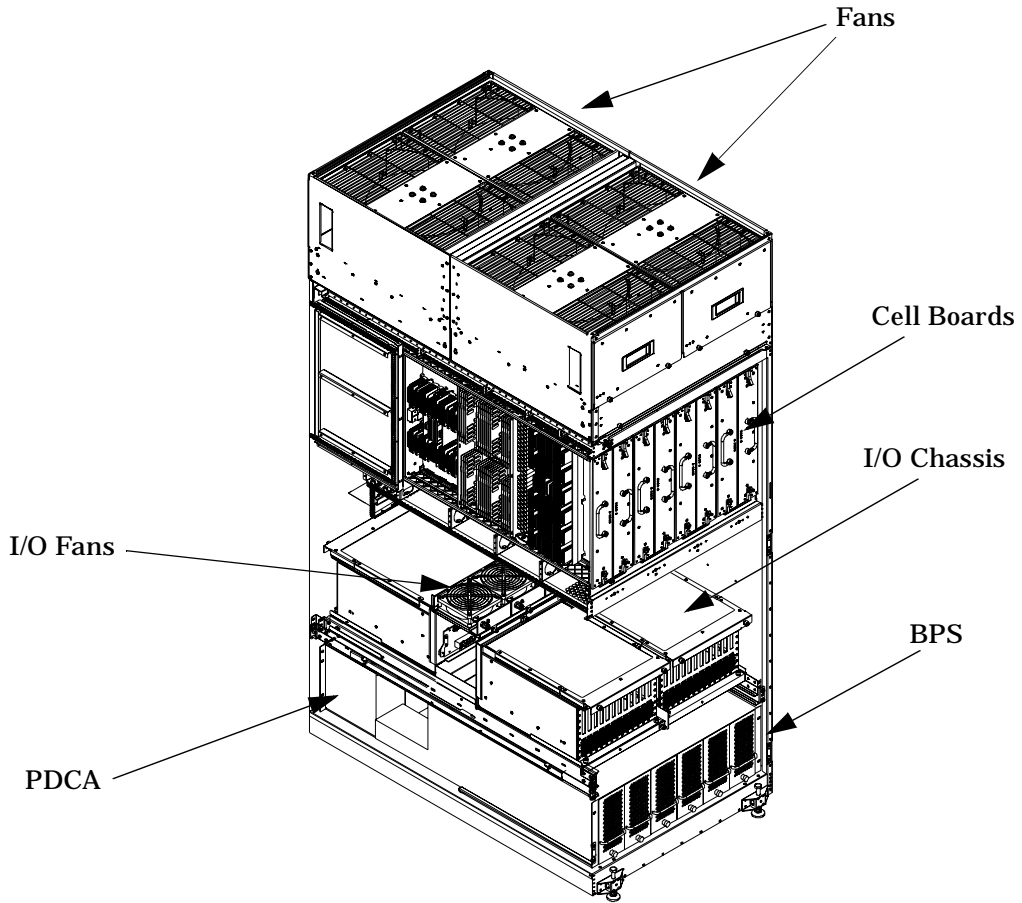
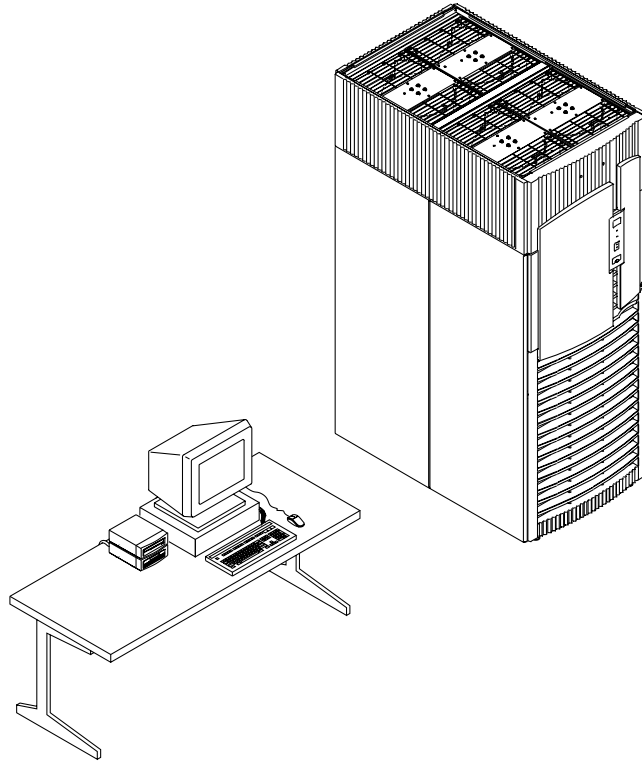
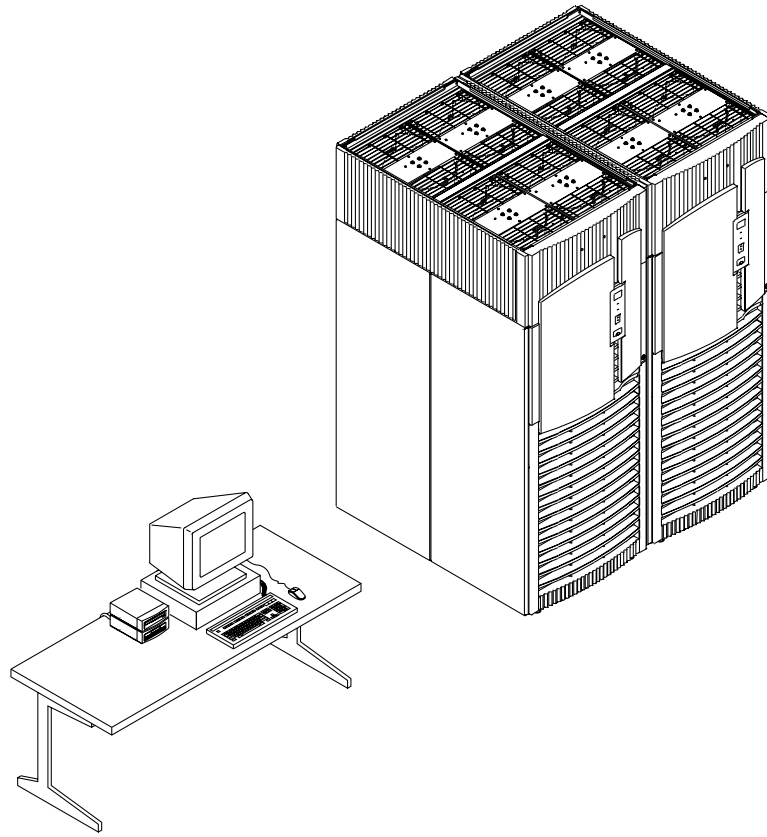

Figure 1-2 **Typical SD16/SD32 Installation**



60SP001A
4/17/00

Figure 1-3 **Typical SD64 Installation**



60SP002A
4/17/00

Figure 1-4 **Typical Installation with IOX**

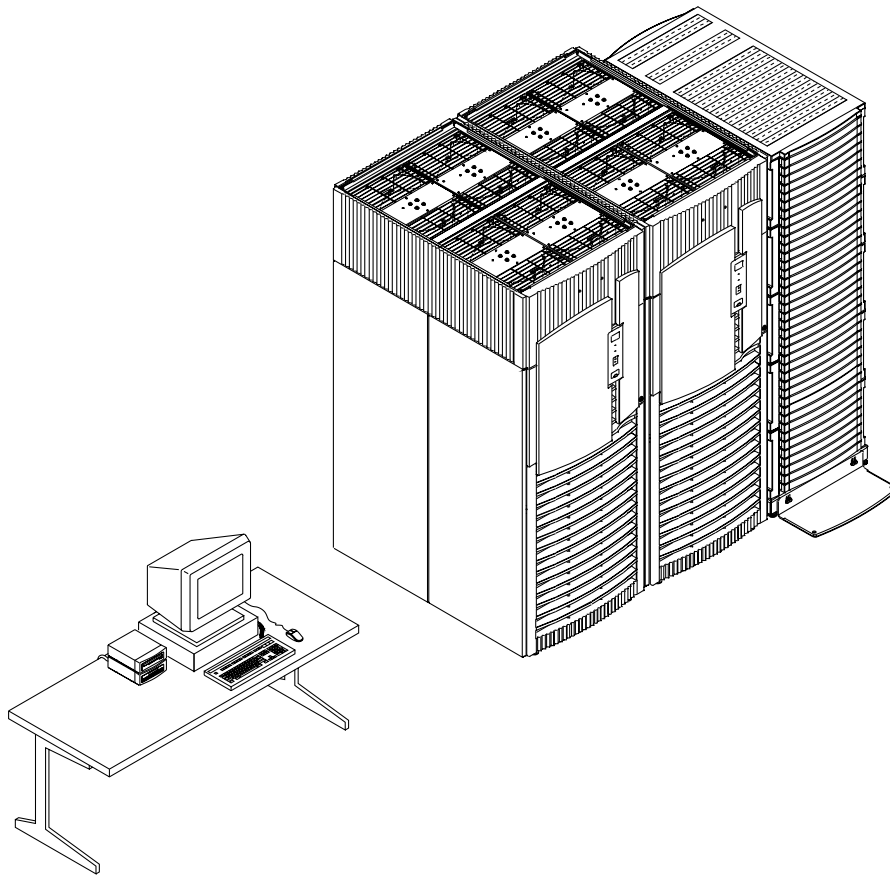

60SP003A
4/26/00

Support Management Station

The hp Integrity Superdome and hp 9000 Superdome SMS is an hp Proliant M350-G3 PC, either a desktop or a rack-mounted unit. The rack-mounted unit uses a TFT-5600 rack-mount LCD monitor and keyboard.

2 Dimensions and Weights

Component Dimensions

Table 2-1 lists the dimensions for the cabinet and components. Table 2-2 list the dimensions for optional IOX cabinets.

Table 2-1 Server Component Dimensions

Component	Width (in. / cm)	Depth (in. / cm)	Height (in. / cm)	Maximum Quantity per Cabinet
Cabinet	30 / 76.2	48 / 121.9	77.2 / 195.6	1
Cell board	16.5 / 41.9	20.0 / 50.2	3.0 / 7.6	8 ^a
Cell board power board (OCPB)	16.5 / 41.9	10.125 / 25.7	3.0 / 7.6	8 ^a
I/O backplane	11 / 27.9	17.6 / 44.7		1
Master I/O backplane	3.25 / 8.3	23.75 / 60.3	1.5 / 3.8	1
I/O cardcage	12.0 / 30.5	17.5 / 44.4	8.38 / 21.3	4
PDCA	7.5 / 19.0	11.0 / 27.9	9.75 / 24.3	2

a. SD16 is limited to a maximum of 4.

Table 2-2 I/O Expansion Cabinet Component Dimensions

Cabinet Type	Height (in. / cm)	Width (in. / cm)	Depth (in. / cm)
E33	63.5 / 161	23.5 / 59.7	77.3 / 196.0
E41	77.5 / 197	23.5 / 59.7	36.5 / 92.7

Component Weights

Table 2-3 lists the server and component weights.

NOTE Refer to the appropriate documents to determine the weight of the SMS and any console that will be used with this server.

Table 2-3 System Component Weights

Component	Weight Per Unit (lb. / kg)	Quantity	Weight (lb. / kg)
Chassis ^a	745.17 / 338.1	1	745.17 / 338.10
Cell Board w/o Power Board and DIMMs	17.23 / 7.81	8	137.84 / 62.54
Cell Power Board	8.05 / 3.65	8	64.40 / 29.20
DIMMs	0.20 / 0.09	256	51.20 / 23.04
Bulk Power Supply (BPS)	3.83 / 1.74	6	23.00 / 10.44
PDCA	26.00 / 11.80	2	52.00 / 23.59
I/O cardcage	36.50 / 16.56	4	146.00 / 66.24
I/O Cards	0.45 / 0.20	48	21.60 / 9.80
Fully configured server (SD32 cabinet)		1	1241.21 / 563.16 ^b

a. The listed weight for a chassis includes the weight of all components not listed in Table 2-3.

b. The listed weight for a fully configured cabinet includes all components and quantities listed in Table 2-3.

Table 2-4 I/O Expansion Cabinet Weights

Component	Weight ^a (lb. / kg)
Fully configured cabinet	1104.9 / 502.2
I/O cardcage	36.50 lbs / 16.56
Chassis	264 lbs / 120

a. The listed weight for a fully configured cabinet includes all items installed in a 1.6 meter cabinet. Add approximately 11 lbs when using a 1.9 meter cabinet.

Shipping Dimensions and Weights

Table 2-5 lists the dimensions and weights of the Support Management Station and a single cabinet with shipping pallet.

Table 2-5 Miscellaneous Dimensions and Weights

Equipment	Width (in. / cm)	Depth/Length (in. / cm)	Height (in. / cm)	Weight (lb. / kg)
System on shipping pallet ^{a b c}	39.00 / 99.06	48.63 / 123.5	73.25 / 186.7)	1360.8lbs / 618.54)
Blowers/Frame on shipping pallet	40.00 / 101.6	48.00 / 121.9	62.00 / 157.5	99.2 lbs / 45.01
I/O Expansion cabinet on shipping pallet ^d	38.00 / 96.52	48.00 / 121.9	88.25 / 224.1	1115 lbs / 505.8

- a. Shipping box, pallet, ramp, and container adds approximately 116 lbs (52.63 kg) to the total system weight.
- b. Blowers/Frame are shipped on a separate pallet.
- c. Size and number of miscellaneous pallets are determined by the equipment ordered by the customer.
- d. Assumes no I/O cards or cables installed. The shipping kit and pallet and all I/O cards adds approximately 209 lbs to the total weight.

3 Electrical Specifications

The following specifications are based on HP Environmental Class C2. Class C2 is a controlled computer room environment where products are subject only to controlled temperature and humidity extremes. Throughout this chapter each specification is defined as thoroughly as possible to ensure that all data is considered to ensure a successful site preparation and system installation.

Grounding

The site building shall provide a safety ground/protective earth for each AC service entrance to all cabinets.

This equipment is CLASS 1 and requires full implementation of the grounding scheme to all equipment connections. Failure to attach Protective Earth results in loss of regulatory compliance and creates a possible safety hazard.

Circuit Breaker

Each cabinet using a three-phase, four-wire input requires dedicated circuit breaker to support the Marked Electrical current of 44A per phase. The facility electrician and local service codes will determine proper circuit breaker selection.

Each cabinet using a three-phase five-wire input requires a dedicated circuit breaker to support the Marked Electrical current of 24A per phase. The facility electrician and local service codes will determine proper circuit breaker selection.

NOTE When using the minimum sized breaker, always choose circuit breakers with the maximum allowed trip delay to avoid nuisance tripping.

Power Options

Table 3-1 describes the available power options. It may be unusual to list Options 6 and 7 and not 1 and 2. The options listed are consistent with previous options for earlier Superdome systems.

Table 3-1 Available Power Options

Option	Source Type	Source Voltage (nominal)	PDCA Required	Input Current Per Phase 200-240 VAC ^a	Power Receptacle Required
6	3-phase	Voltage range 200-240 VAC, phase-to-phase, 50 Hz or 60 Hz	four-wire	44A Maximum per phase	Connector and plug provided with a 2.5-meter power cable. Electrician must hard-wire receptacle to 60A site power.
7	3-phase	Voltage range 200-240 VAC, phase-to-neutral, 50 Hz or 60 Hz	five-wire	24A Maximum per phase	Connector and plug provided with a 2.5-meter power cable. Electrician must hard-wire receptacle to 32A site power.

a. A dedicated branch circuit is required for each PDCA installed.

Table 3-2 Option 6 and 7 Specifics

PDCA Part Number	Attached Power Cord	Attached Plug	Receptacle Required
A5201-69023 (Option 6)	OLFLEX 190 (PN 600804) is a 2.5 meter multi conductor, 600 volt, 90 degree C, UL and CSA approved, oil resistant flexible cable. (8 AWG 60 A capacity)	Mennekes ME 460P9 (60 A capacity)	Mennekes ME 460R9 (60 A capacity)
A5201-69024 (Option 7)	H07RN-F (OLFLEX PN 1600130) is a 2.5 meter heavy duty neoprene jacketed harmonized European flexible cable. (4 mm ² 32A capacity)	Mennekes ME 532P6-14 (32A capacity)	Mennekes ME 532R6-1500 (32 A capacity)

NOTE A qualified electrician must wire the PDCA receptacle to site power using copper wire and in compliance with all local codes.

Each branch circuit used within a complex must be connected together to form a common ground.

When only one PDCA is to be installed in a system cabinet, it must be installed as PDCA0. Refer to Figure 3-1 for PDCA0 location.

NOTE When wiring a PDCA, phase rotation is unimportant. When using two PDCAs, however, the rotation must be consistent for both.

Figure 3-1 PDCA Locations

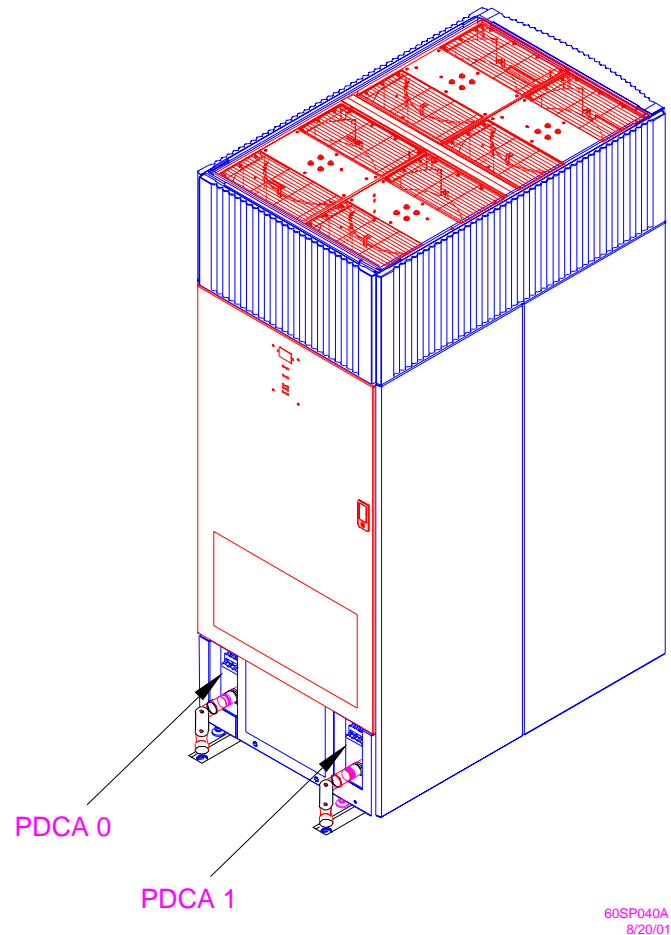

Power Cords

This section discusses the different possibilities for PDCA power cords.

Pre-wired PDCAs Options 6 and 7

All servers are delivered with the appropriate cable and plug. The mating in-line connector is not provided.

IMPORTANT Verify that the source power is correct for the appropriate PDCA wiring.

NOTE When installing the power connector, allow enough room for mating the connector with the plug.

Check the voltages at the connector prior to connecting the newly installed connector to the PDCA plug. Refer to Figure 3-3 and Figure 3-4 on page 19 for pin locations.

Power Options

- To verify the proper wiring for a 4-wire PDCA, use a DVM to measure the voltage at the in-line connector. Voltage should read 200 - 240 Vac phase-to-phase as measured between the connector pins as follows: L1 to L2, L2 to L3, L1 to L3.
- To verify the proper wiring for a 5-wire PDCA, use a DVM to measure the voltage at the connector. Voltage should read 200 - 240 Vac phase-to-neutral as measured between the connector pins as follows: L1 to N, L2 to N, L3 to N.

Figure 3-2 PDCA Assembly for Options 6 and 7 (4-Wire Unit Shown)

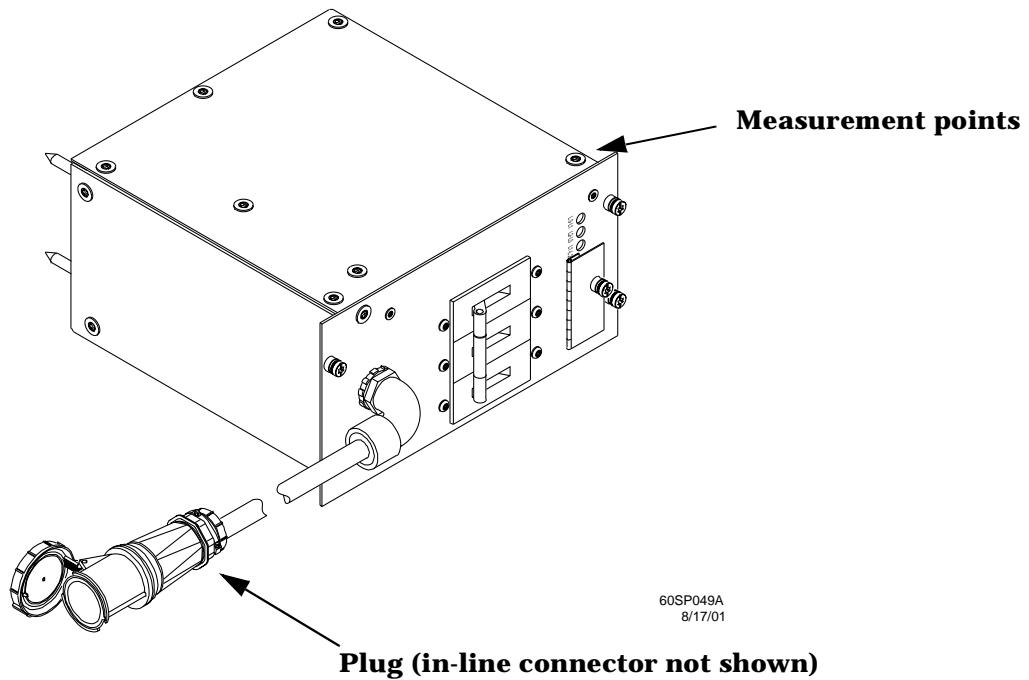

IMPORTANT Ensure that your DVM is capable of measuring AC voltages of at least 500VAC. A number of 5-wire power distribution systems may have phase-to-phase voltages in excess of 400VAC. Many hand-held volt meters are limited to 300VAC.

Figure 3-3 Four-Wire In-Line Connector (A4660A Opt 401)

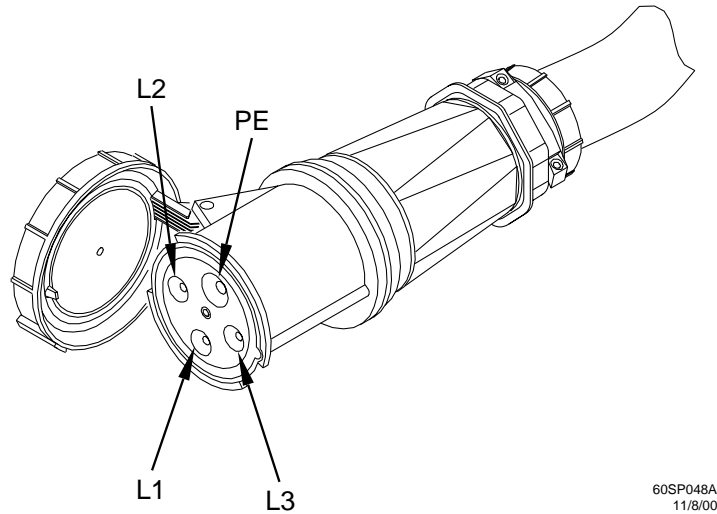
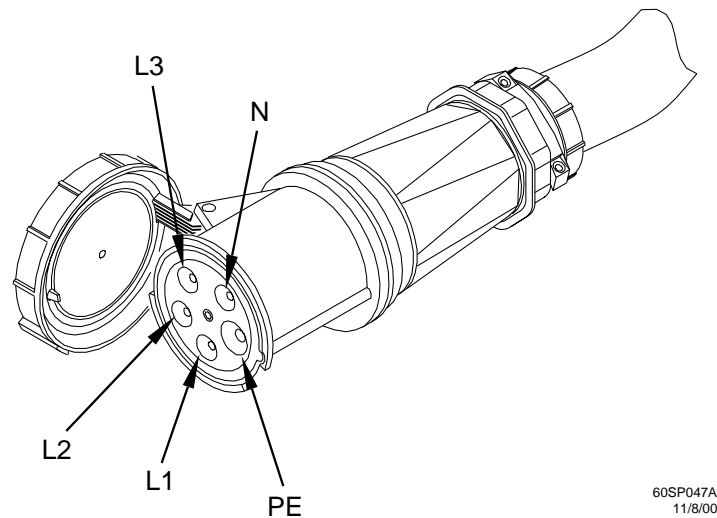

Figure 3-4 Five-Wire In-Line Connector (A4660A Opt 501)



Cable Removal

Some installations may either require or desire that the cabinet(s) be hardwired in lieu of using the standard plugs and connectors provided. In these cases, it is necessary to remove the installed power cable from the PDCA. The following procedures are used to remove and replace the existing power cable.

Power Options

To remove the existing cable from the PDCA, begin by removing the five T-10 Torx screws detailed in Figure 3-5 on page 21. Then remove the bottom panel of the PDCA. Retain the panel and screws for future use.

NOTE The cable removal and installation requires only the bottom panel to be removed. For image clarity, Figure 3-5 does not show cable or cable strain relief.

Step 1. Locate and remove the PDCAs.

Step 2. Remove the five screws securing the bottom of the PDCA. Retain the screws. Refer to Figure 3-5 for details.

Step 3. Disconnect the existing wires from the PDCA terminal lugs. Refer to Figure 3-5 for details.

NOTE Loosen the cable side terminal lugs only. Do not loosen the PDCA side terminal lugs.

NOTE For 5-wire cables, loosen four lugs. For 4-wire cables, loosen three lugs.

Step 4. Using an 11-mm socket, remove the safety ground cable (green and yellow cable). Retain the attaching hardware.

Step 5. Remove the cable from the PDCA. Keep all retaining hardware for use during installation of the new cable.

Figure 3-5 PDCA Cable Access (5-Wire Unit Shown)

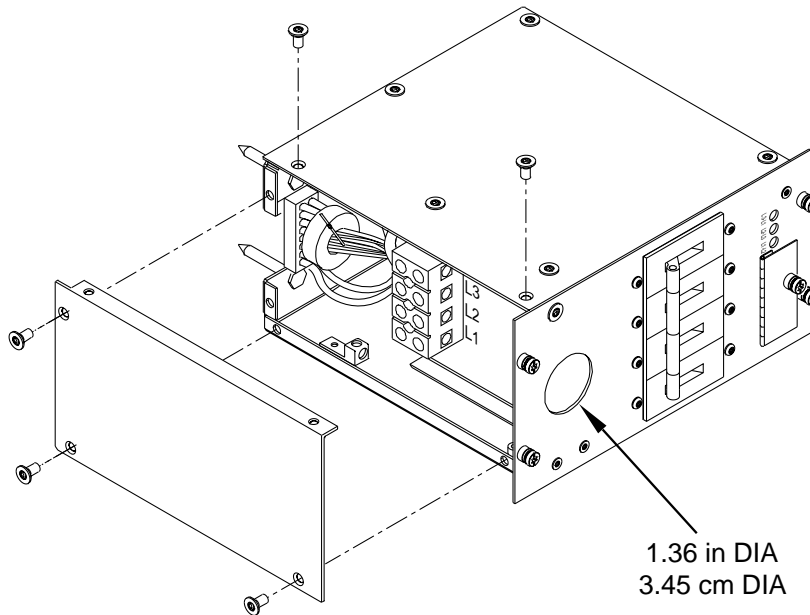

60SP042C
1/7/00

Figure 3-6 PDCA Input Wiring Connections (5-Wire Unit Shown)

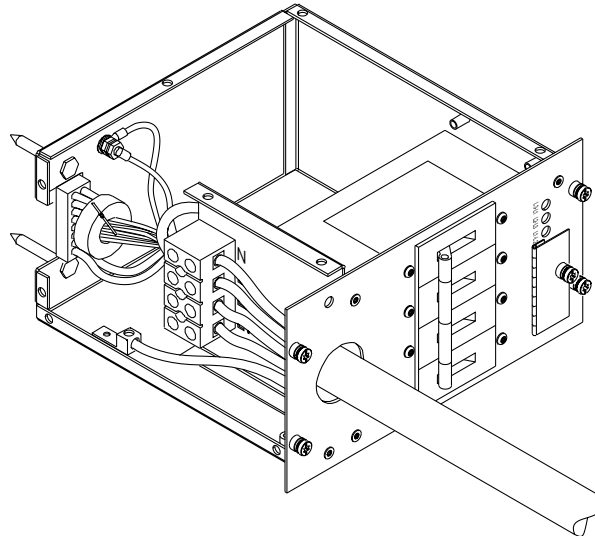

60SP041A
7/13/00

Cable Installation

NOTE These procedures may be used for early deliveries consisting of either option 1 or option 2 as well as those later systems delivered with PDCA cables attached.

Select the proper cable using the following criteria.

- Each cabinet using a 3-phase, 4-wire input is required to have a four-conductor cable. The four-conductor cable selected by the facility electrician shall be in accordance with local electrical codes to support the selected circuit breaker for the maximum Product Label current of 44A per phase. The facility electrician and local electrical codes will determine proper power cord selection dependent upon desired application such as rigid conduit, flexible conduit, or cable bundle. Observe derating factors for multiple wires per cable.
- Each cabinet using a 3-phase 5-wire input is required to have a five-conductor cable. The five-conductor cable selected by the facility electrician shall be in accordance with local electrical codes to support the selected circuit breaker for the maximum Product Label current of 24A per phase. The facility electrician and local electrical codes will determine proper power cord selection dependent upon desired application such as rigid conduit, flexible conduit, or cable bundle. Observe derating factors for multiple wires per cable.

Step 1. Prepare the new cable as shown in Figure 3-7 on page 23.

Step 2. Using the cable retaining hardware saved from the cable removal, route the new cable into the PDCA.

Step 3. Route the cable into the PDCA terminal lugs and secure in position by tightening the lugs.

Step 4. Using the hardware that was retained during the cable removal, attach the green and yellow ground cable.

- Step 5.** Using the five screws retained from the removal procedure, replace the bottom panel on the PDCA. Refer to Figure 3-5 on page 21 for panel installation details.
- Step 6.** To verify the proper wiring to a 4-wire PDCA, use a DVM to measure the voltage at the test points. Voltage should read 200 - 240 Vac phase-to-phase as measured between the test points as follows: L1 to L2, L2 to L3, L1 to L3.

IMPORTANT In some electrical distributions around the world, it is possible to measure 415 VAC phase-to-phase. Ensure that your DVM is capable of measuring AC voltages of at least 500VAC. A number of 5-wire power distribution systems may have phase-to-phase voltages in excess of 400VAC. Many hand-held volt meters are limited to 300VAC.

To verify the proper wiring to a 5-wire PDCA, use a DVM to measure the voltage at the test points. Voltage should read 200-240VAC phase-to-neutral, as measured between the test points as follows: L1 to N, L2 to N, L3 to N.

Figure 3-7 Cable Preparation Detail

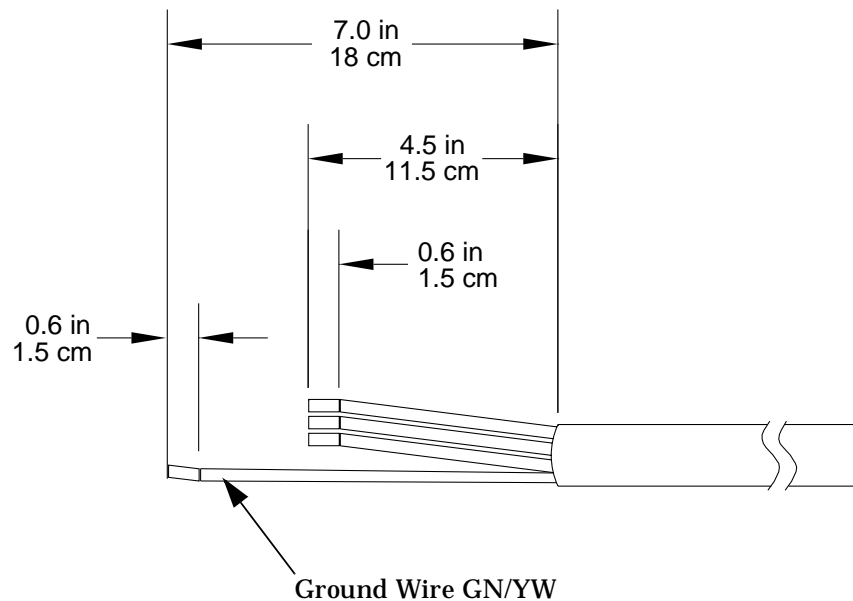

NOTE Dimensions shown are for a cable strain relief without an extension nipple. If an extension nipple is used, then the cable jacket must be removed accordingly.

NOTE Figure 3-7 shows a 4-wire cable for illustrative purposes only. 5-wire cable is dimensionally identical regarding insulation and jacket removal. The only exception is the number of conductors.

Figure 3-8 PDCA (Five Wire) Input Wiring Connections

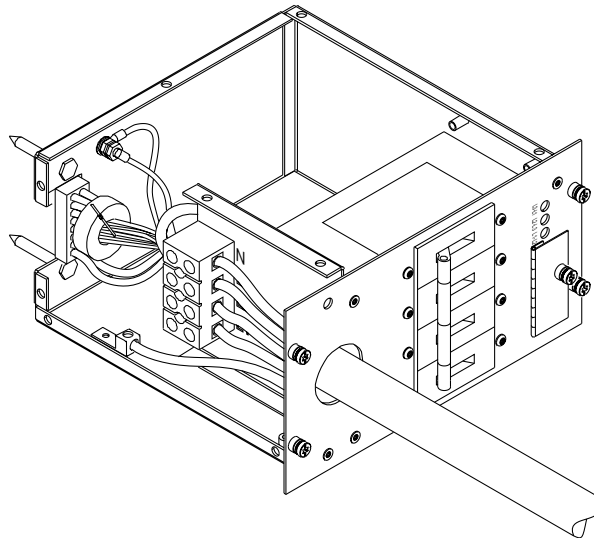

60SP041A
7/13/00

Figure 3-9 PDCA (Four Wire) Input Wiring Connections

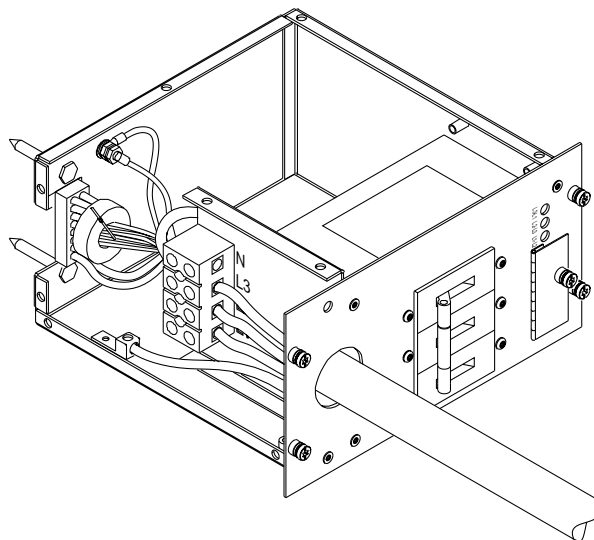

60SP041B
7/13/00

Customer Installation Options

Figure 3-10 and Figure 3-11 detail a suggested configuration for connecting the PDCA when the use of rigid conduit is required or desired. Using a 2- to 4-inch nipple and a 90o elbow allows the conduit to pass through the raised floor at a point immediately past the cabinet. This prevents the conduit from extending beyond the cabinet.

Figure 3-10 PDCA Conduit Connection

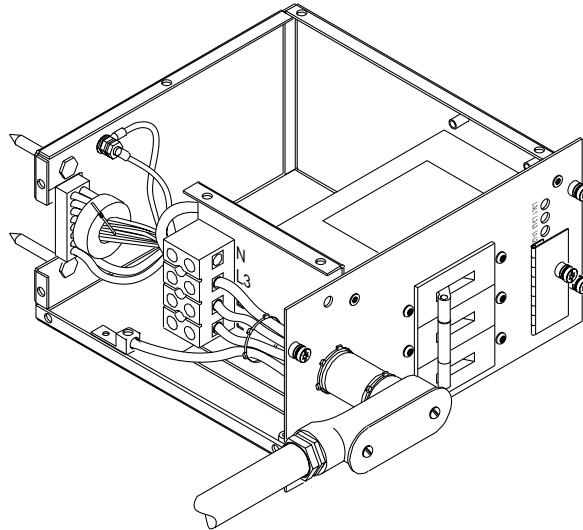

60SP046A
8/18/00

Figure 3-11 Conduit Required for PDCA Connection

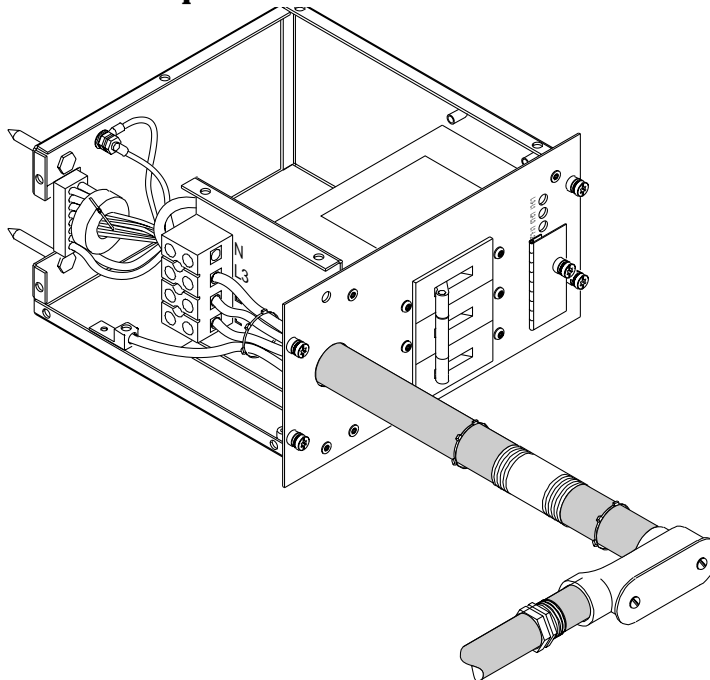

60SP045A
8/18/00

System Power Requirements

Table 3-3 and Table 3-4 list the AC power requirements for a hp Integrity Superdome and hp 9000 Superdome systems. These tables provide information to help determine the amount of AC power needed for your computer room.

Table 3-3 Power Requirements (without Support Management Station)

Requirements	Value	Comments
Nominal input voltage	200/208/220/230/240 (VAC rms)	
Input voltage range (minimum - maximum)	200 - 240 (VAC rms)	Autoselecting (measured at input terminals)
Frequency range (minimum - maximum)	50/60 (Hz)	
Number of phases	3	
Maximum inrush current	90 (A peak)	
Product Label maximum current, three-phase, four-wire	44 (A rms)	Per phase at 200-240VAC
Product Label maximum current, three-phase, five-wire	24 (A rms)	Per phase at 200-240VAC
Power factor correction	0.95 minimum	
Ground leakage current (mA)	> 3.5 ma	See WARNING below.

WARNING Beware of shock hazard. When connecting or removing input power wiring, always connect the ground wire first and disconnect it wire last.

Component Power Requirements

Table 3-3 and Table 3-4 list the AC power requirements for a hp Integrity Superdome and hp 9000 Superdome systems. These tables provide information to help determine the amount of AC power needed for your computer room.

Table 3-4 Component Power Requirements (without Support Management Station)

Power Required 50Hz or 60 Hz^a	VA
Maximum configuration for SD16	8,200
Maximum configuration for SD32	12,196
Cell Board	900
I/O Cardcage	500

- a. A number that should be used for planning to allow for enough power to upgrade through the life of the system.

I/O Expansion Cabinet Power Requirements

The I/O expansion cabinet requires a single phase 200-240VAC input. Table 3-5 lists the AC power requirements for the I/O expansion cabinet.

NOTE The IOX accommodates two AC inputs for redundancy

Table 3-5 I/O Expansion Cabinet Power Requirements (without Support Management Station)

Requirements	Value
Nominal input voltage	200/208/220/230/240 (VAC rms)
Input voltage range (minimum-maximum)	200-240 (VAC rms)
Frequency range (minimum-maximum)	50/60 (Hz)
Number of phases	1
Marked Electrical input current	16A
Maximum inrush current	60 max (A peak)
Power factor correction	0.95 minimum

Table 3-6 I/O Expansion Cabinet Component Power Requirements

Power Required (50 - 60 Hz)	VA
Fully configured cabinet	3200
I/O cardcage	500
ICE	600

I/O Expansion Cabinet Power Cords

Table 3-7 lists the power cords for the I/O expansion cabinet.

Table 3-7 I/O Expansion Cabinet AC Power Cords

Part Number A5499AZ	Where Used	Connector Type
-001	North America	L6-20
-002	International	IEC 309

4 Environmental Requirements

Temperature and Humidity Specifications

Table 4-1 Controlled Computer Room Environment Specifications

Temperature (dry bulb °C) ^a		Relative Humidity %; Non condensing		Dew Point ^b	Rate of Change (°C/hr., max)
Allowable ^{c,d}	Recommended ^e	Allowable ^d	Recommended ^e		
15 to 32 (59° to 90° F)	20 to 25 (68° to 77° F)	20 to 80	40 to 55	17	5

- a. Dry bulb temperature is the regular ambient temperature. Derate maximum dry bulb temperature 1°C/300 m above 900 m.
- b. Must be non-condensing environment.
- c. With installed media, the minimum temperature is 15°C and maximum relative humidity is limited to 80%. Specific media requirements may vary.
- d. Allowable: equipment design extremes as measured at the equipment inlet.
- e. Recommended: target facility design and operational range.

Table 4-2 Power-Off Storage and Shipping Requirements

Storage			Powered Off (installed)		
Temp (°C, dry bulb - regular ambient temp.)	Relative Humidity % Non-condensing	Dew point (max)	Temp (°C, dry bulb - regular ambient temp.)	Relative Humidity % Non-condensing	Dew point (max)
-40 to +60	8 to 90	32	5 to 45 ^a	8 to 90	29

- a. The room ambient temperature must be returned to normal operating conditions and sufficient time is given for the equipment to return to thermal equilibrium and stabilize.

Power Dissipation

Table 4-3 and Table 4-4 show the power requirements by configuration (i.e. number of cell boards, amount of memory per cell, and number of I/O chassis) for the hp Integrity Superdome and the hp 9000 Superdome, respectively.

There are two columns of power numbers (Watts). The Power Breaker column shows the power used to size the wall breaker at the installation site. The Typical Power column shows typical power. Typical power numbers may be used to assess average utility cost of cooling and electrical power. These tables also show the recommended breaker sizes for 4-wire and 5-wire sources

Table 4-3 Typical hp Integrity Superdome Configurations

Cell	Memory	IO	Typical (Watts)	Cooling (BTU/Hr.)	Breaker Power (Watts) ^a	3-Pole Breaker Size (Amperes) ^{a,b}	4-Pole Breaker Size (Amperes) ^{a,c,d}
8	32	4	9790	33406	12335	40	25
8	16	2	8450	28834	10647	40	25
8	8	4	8680	29619	10937	40	25
8	8	2	8170	27878	10294	35	20
8	4	4	8400	28663	10584	35	20
8	4	2	7700	26275	9702	35	20
6	16	4	7370	25149	9286	35	20
6	16	2	6660	22726	8392	30	20
6	8	4	7010	23920	8833	30	20
6	8	2	6300	21497	7938	30	20
6	4	4	6800	23204	8568	30	20
6	4	2	6100	20815	7686	30	20
4	16	4	5880	20064	7409	30	20
4	16	2	5170	17642	6514	30	20
4	8	4	5340	18222	6728	30	20
4	8	2	4630	15799	5834	25	20
4	4	4	5200	17744	6552	25	20
4	4	2	4500	15355	5670	25	20
2	16	2	3800	12967	4788	20	20
2	8	2	3500	11943	4410	20	20
2	4	2	3400	11602	4284	20	20

- a. These numbers are valid only for the specific configurations shown. Any upgrades may require a change to the breaker size. A 5-wire source utilizes a 4 pole breaker and a 4-wire source utilizes a 3 pole breaker. *The PE (Protective Earth) ground wire is not switched.*
- b. An input power source supplied from a 3-pole plus protective earth (PE), 4-wire system will always be wired as 240 volts phase-to-phase, no neutral or common, plus a PE ground. Three phase input voltage (240VAC) to the equipment is connected phase-to-phase. Examples of 4 wire: 200-volt phase-to-phase, 208-volt phase-to-phase, 220-volt phase-to-phase, 230-volt phase-to-phase, 240-volt phase-to-phase.

c. An input power source supplied from a three-pole plus PE, four-wire system may be wired as either:

- 200VAC phase-to-phase, plus a PE ground. The three phase input voltage to the equipment is connected phase-to-phase. The neutral terminal in the PDCA is not connected.
- 208VAC phase-to-phase, plus a PE ground. The three phase input voltage to the equipment is connected phase-to-phase. The neutral terminal in the PDCA is not connected.
- 220VAC phase-to-phase, plus a PE ground, plus a PE ground. Three phase input voltage to the equipment is connected phase-to-phase. The neutral terminal in the PDCA is not connected.
- 230VAC phase-to-phase, plus a PE ground. The three phase input voltage to the equipment is connected phase-to-phase. The neutral terminal in the PDCA is not connected.
- 240VAC phase-to-phase, plus a PE ground. The three phase input voltage to the equipment is connected phase-to-phase. The neutral terminal in the PDCA is not connected.

d. An input power source supplied from a four-pole plus neutral plus PE, five-wire system may be wired as either:

- 200VAC phase-to-neutral, plus a PE ground. The three phase input voltage to the equipment is connected phase-to-neutral. The neutral wire is connected to the PDCA neutral terminal.
- 208VAC phase-to-neutral, with a neutral return, plus a PE ground. Three phase input voltage to the equipment is connected phase-to-neutral. The neutral wire is connected to the PDCA neutral terminal.
- 220VAC phase-to-neutral, plus a PE ground. The three phase input voltage to the equipment is connected phase-to-neutral. The neutral wire is connected to the PDCA neutral terminal.
- 230VAC phase-to-neutral, plus a PE ground. The three phase input voltage to the equipment is connected phase-to-neutral. The neutral wire is connected to the PDCA neutral terminal.
- 240VAC phase-to-neutral, plus a PE ground. The three phase input voltage to the equipment is connected phase-to-neutral. The neutral wire is connected to the PDCA neutral terminal.
- 415VAC phase-to-neutral, plus a PE ground. The three phase input voltage to the equipment is connected phase-to-neutral. The neutral wire is connected to the PDCA neutral terminal.

WARNING: Do not connect a 380 to 415VAC supply to a four-wire PDCA. This is a safety hazard and will result in damage to the product. Line-to-line or phase-to-phase voltage measured at 380 to 415VAC must always be connected using a 5-wire PDCA.

Table 4-4 Typical hp 9000 Superdome Configurations

Cell	Memory	IO	Typical (Watts)	Cooling (BTU/Hr.)	Breaker Power (Watts) ^a	3-Pole Breaker Size (Amperes) ^{a,b}	4-Pole Breaker Size (Amperes) ^{a,c,d}
8	32	4	9038	30840	11388	40	25
8	16	2	7698	26268	9699	40	25
8	8	4	7928	27053	9989	40	25
8	8	2	7418	25312	9347	35	20
8	4	4	7648	26097	9636	35	20
8	4	2	6948	23709	8754	35	20
6	16	4	6806	23224	8576	35	20
6	16	2	6096	20801	7681	30	20
6	8	4	6446	21996	8122	30	20
6	8	2	5736	19573	7227	30	20
6	4	4	6236	21279	7857	30	20
6	4	2	5536	18890	6975	30	20
4	16	4	5504	18781	6935	30	20
4	16	2	4794	16359	6040	30	20
4	8	4	4964	16939	6255	30	20
4	8	2	4254	14516	5360	25	20
4	4	4	4824	16461	6078	25	20
4	4	2	4124	14072	5196	25	20
2	16	2	3612	12325	4551	20	20
2	8	2	3312	11302	4173	20	20
2	4	2	3212	10960	4047	20	20

- a. These numbers are valid only for the specific configurations shown. Any upgrades may require a change to the breaker size. A 5-wire source utilizes a 4 pole breaker and a 4-wire source utilizes a 3 pole breaker. *The PE (Protective Earth) ground wire is not switched.*
- b. An input power source supplied from a 3-pole plus protective earth (PE), 4-wire system will always be wired as 240 volts phase-to-phase, no neutral or common, plus a PE ground. Three phase input voltage (240VAC) to the equipment is connected phase-to-phase. Examples of 4 wire: 200-volt phase-to-phase, 208-volt phase-to-phase, 220-volt phase-to-phase, 230-volt phase-to-phase, 240-volt phase-to-phase.

c. An input power source supplied from a three-pole plus PE, four-wire system may be wired as either:

- 200VAC phase-to-phase, plus a PE ground. The three phase input voltage to the equipment is connected phase-to-phase. The neutral terminal in the PDCA is not connected.
- 208VAC phase-to-phase, plus a PE ground. The three phase input voltage to the equipment is connected phase-to-phase. The neutral terminal in the PDCA is not connected.
- 220VAC phase-to-phase, plus a PE ground, plus a PE ground. Three phase input voltage to the equipment is connected phase-to-phase. The neutral terminal in the PDCA is not connected.
- 230VAC phase-to-phase, plus a PE ground. The three phase input voltage to the equipment is connected phase-to-phase. The neutral terminal in the PDCA is not connected.
- 240VAC phase-to-phase, plus a PE ground. The three phase input voltage to the equipment is connected phase-to-phase. The neutral terminal in the PDCA is not connected.

d. An input power source supplied from a four-pole plus neutral plus PE, five-wire system may be wired as either:

- 200VAC phase-to-neutral, plus a PE ground. The three phase input voltage to the equipment is connected phase-to-neutral. The neutral wire is connected to the PDCA neutral terminal.
- 208VAC phase-to-neutral, with a neutral return, plus a PE ground. Three phase input voltage to the equipment is connected phase-to-neutral. The neutral wire is connected to the PDCA neutral terminal.
- 220VAC phase-to-neutral, plus a PE ground. The three phase input voltage to the equipment is connected phase-to-neutral. The neutral wire is connected to the PDCA neutral terminal.
- 230VAC phase-to-neutral, plus a PE ground. The three phase input voltage to the equipment is connected phase-to-neutral. The neutral wire is connected to the PDCA neutral terminal.
- 240VAC phase-to-neutral, plus a PE ground. The three phase input voltage to the equipment is connected phase-to-neutral. The neutral wire is connected to the PDCA neutral terminal.
- 415VAC phase-to-neutral, plus a PE ground. The three phase input voltage to the equipment is connected phase-to-neutral. The neutral wire is connected to the PDCA neutral terminal.

WARNING: Do not connect a 380 to 415VAC supply to a four-wire PDCA. This is a safety hazard and will result in damage to the product. Line-to-line or phase-to-phase voltage measured at 380 to 415VAC must always be connected using a 5-wire PDCA.

Acoustic Noise Specification

The acoustic noise specification as follows:

- 8.2 bel (sound power level)
- 65.1 dBA (sound pressure level at operator position)

The above levels are appropriate for dedicated computer room environments, not office environments.

Care should be taken to understand the acoustic noise specifications relative to operator positions within the computer room or when adding systems to computer rooms with existing noise sources.

Air Flow

hp Integrity Superdome and hp 9000 Superdome systems require the cabinet air intake temperature to be between 20° C and 30° C at 2400 CFM. Any cooling system layouts described in Chapter 2 can be adapted to cool the system.

Figure 4-1 on page 39 illustrates the location of the inlet and outlet airducts on a single cabinet.

Figure 4-1 **Airflow Diagram**

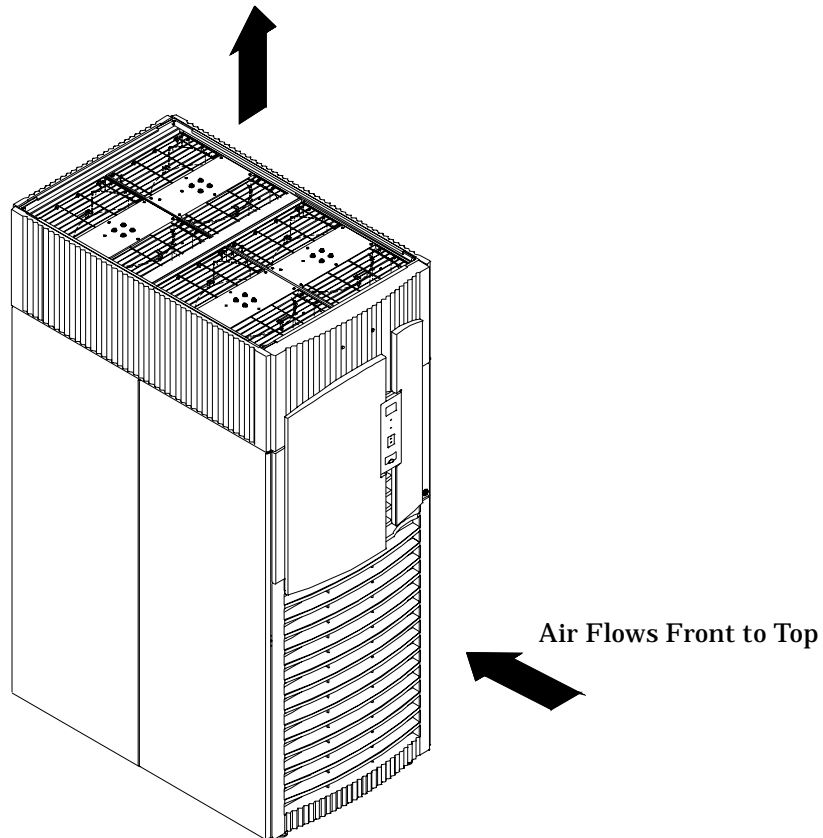

5 Facility Guidelines

Electrical and Environmental Guidelines

Electrical Factors

Proper design and installation of a power distribution system for a server requires specialized skills. Those responsible for this task must have a thorough knowledge and understanding of appropriate electrical codes and the limitations of the power systems for computer and data processing equipment.

In general, a well-designed power distribution system exceeds the requirements of most electrical codes. A good design, when coupled with proper installation practices, produces the most trouble-free operation.

A detailed discussion of power distribution system design and installation is beyond the scope of this document. However, electrical factors relating to power distribution system design and installation must be considered during the site preparation process.

The electrical factors discussed in this section are:

- Computer room safety
- Electrical load requirements (circuit breaker sizing)
- Power quality
- Distribution hardware
- System installation guidelines

Computer Room Safety

Inside the computer room, fire protection and adequate lighting (for equipment servicing) are important safety considerations. Federal and local safety codes govern computer installations.

Fire Protection The National Fire Protection Association's Standard for the Protection of Electronic Computer Data Processing Equipment, NFPA 75, contains information on safety monitoring equipment for computer rooms.

Most computer room installations are equipped with the following fire protection devices:

- Smoke detectors
- Fire and temperature alarms
- Fire extinguishing system

Additional safety devices are:

- Circuit breakers
- An emergency power cutoff switch
- Devices specific to the geographic location, i.e., earthquake protection

Lighting Requirements for Equipment Servicing Adequate lighting and utility outlets in a computer room reduce the possibility of accidents during equipment servicing. Safer servicing is also more efficient and, therefore, less costly.

For example, it is difficult to see cable connection points on the hardware if there is not enough light. Adequate lighting reduces the chances of connector damage when cables are installed or removed.

The minimum recommended illumination level is 70 foot-candles (756 lumens per square meter) when the light level is measured at 30 inches (76.2 cm) above the floor.

Power Quality

This equipment is designed to operate over a wide range of voltages and frequencies. It has been tested and shown to comply with EMC Specification EN50082. However, damage can occur if these ranges are exceeded. Severe electrical disturbances can exceed the design specifications of the equipment.

Sources of Electrical Disturbances Electrical disturbances, glitches, affect the quality of electrical power. Common sources of these disturbances are:

- Fluctuations occurring within the facility's distribution system
- Utility service low-voltage conditions (such as sags or brownouts)
- Wide and rapid variations in input voltage levels
- Wide and rapid variations in input power frequency
- Electrical storms
- Large inductive sources (such as motors and welders)
- Faults in the distribution system wiring (such as loose connections)
- Microwave, radar, radio, or cell phone transmissions

Power System Protection Computer systems can be protected from the sources of many of these electrical disturbances by using:

- A Protective Earth (PE) connection with a wire diameter of at least equal to the current carrying conductors. The neutral conductor must not be used for the PE connection. (The PE wire is GREEN with a YELLOW stripe.)
- A dedicated power distribution system
- Power conditioning equipment
- Over- and under-voltage detection and protection circuits
- Screening to cancel out the effects of undesirable transmissions
- Lightning arresters on power cables to protect equipment against electrical storms

Every precaution has been taken during power distribution system design to provide immunity to power outages of less than one cycle. However, testing cannot conclusively rule out loss of service. Therefore, adherence to the following guidelines provides the best possible performance of power distribution systems for server equipment:

- Dedicated power source—Isolates server power distribution system from other circuits in the facility.
- Missing-phase and low-voltage detectors—Shuts equipment down automatically when a severe power disruption occurs. For peripheral equipment, these devices are recommended but optional.
- Online uninterruptable power supply (UPS)—Keeps input voltage to devices constant and should be considered if outages of one-half cycle or more are common. Refer to qualified contractors or consultants for each situation.

Distribution Hardware

This section describes wire selection and the types of raceways (electrical conduits) used in the distribution system. Wire size is dictated by circuit breaker sizing and local safety codes.

Wire Selection Use copper conductors instead of aluminum, as aluminum's coefficient of expansion differs significantly from that of other metals used in power hardware. Because of this difference, aluminum conductors can cause connector hardware to work loose, overheat, and fail.

Raceway Systems (Electrical Conduits) Raceways (electrical conduits) form part of the protective ground path for personnel and equipment. Raceways protect the wiring from accidental damage and also provide a heat sink for the wires.

Any of the following types may be used:

- Electrical metallic tubing (EMT) thin-wall tubing
- Rigid (metal) conduit
- Liquidtight with RFI strain relief (most commonly used with raised floors)
- Plenum-grade cables

Building Distribution All building feeders and branch circuitry should be in rigid metallic conduit with proper connectors (to provide ground continuity). Conduit that is exposed and subject to damage should be constructed of rigid galvanized steel.

The IOX and hp Integrity Superdome or hp 9000 Superdome are safety grounded through the green (ground) wire in each AC power cord. In the IOX, this ground passes through the AC power cord entry into the XPC and connects internally to the XPC chassis. The XUC chassis and each ICE chassis are grounded through their respective DC power cords from the XPC. Additional safety grounding must be provided for networking equipment.

Power Routing Power drops and interface cables from the equipment are routed down from the power panel, through a grommet-protected opening (beneath the floor level), and under the floor panels.

Grounding Systems

Superdome servers require two methods of grounding:

- Power distribution safety grounding
- High frequency intercabinet grounding

Power Distribution Safety Grounding The power distribution safety grounding system consists of connecting various points in the power distribution system to earth ground using green (green/yellow) wire ground conductors. Having these ground connections tied to metal chassis parts that may be touched protects computer room personnel against shock hazard from current leakage and fault conditions.

Power distribution systems consist of several parts. Hewlett-Packard recommends that these parts be solidly interconnected to provide an equipotential ground to all points.

Main Building Electrical Ground The main electrical service entrance equipment should have an earth ground connection, as required by applicable codes. Connections such as a grounding rod, building steel, or a conductive type cold water service pipe provide an earth ground.

Electrical Conduit Ground To provide a continuous grounding system, all electrical conduits should be made of rigid metallic conduit that is securely connected together or bonded to panels and electrical boxes.

Power Panel Ground Each power panel should be grounded to the electrical service entrance with green (green/yellow) wire ground conductors. The green (green/yellow) wire ground conductors should be sized per applicable codes (based on circuit over current device ratings).

NOTE The green wire ground conductor mentioned above may be a black wire marked with green tape.

Computer Safety Ground Ground all computer equipment with the green (green/yellow) wire included in the branch circuitry. The green (green/yellow) wire ground conductors should be connected to the appropriate power panel and should be sized per applicable codes (based on circuit over current device ratings).

Superdome was approved by regulatory agencies around the world, and therefore requires a ground/protective earth. there are no exclusions to this regulatory approval.

High-frequency grounding between IOX and Superdome is provided by the cabinet-to-cabinet signal cabling. Whenever an IOX is connected to a Superdome cabinet, low-frequency grounding between these two cabinets is provided by a ground strap. This ground strap is shipped with each IOX. Refer to the *I/O Expansion Cabinet Guide* for more detail.

Newtwork-connected Equipment Ground The installation must provide a ground connection for the network equipment. This statement is translated into the following two languages as required:

WARNING Sweden: Apparaten skall anslutas till jordat uttag, när den ansluts till ett nätverk.

WARNING Denmark: Før tilslutning af de øvrige ledere, se medfølgende installationsvejledning.

Raised Flooring, Signal Reference Grids, and High Frequency Grounding

If a raised floor system is used, install a complete signal reference grid (SRG) for maintaining equal potential over a broad range of frequencies. The grid should be connected to power source X0 and cabinet grounds as well as to other electrical service grounds. Flat braid offers superior frequency controls to round wire. Figure 5-1 on page 46 illustrates a metallic strip grounding system.

NOTE Regardless of the grounding connection method used, the raised floor should be grounded as an absolute safety minimum. For more information regarding raised computer floors, see NEC section 645-15.

HP recommends the following approaches:

- Excellent—Add a grounding grid to the subfloor. The grounding grid should be made of flat braid copper strips in a 2 ft. by 2 ft. manner mounted to the subfloor. The strips should be 0.032 in. (0.08 cm) thick and a minimum of 3.0 in. (8.0 cm) wide. Connect each pedestal to four strips using 1/4-in (6.0-mm) bolts tightened to the manufacturer's torque recommendation.
- Better—A grounded #6 or #4 AWG 2 ft. by 2 ft. copper wire grid mechanically clamped to floor pedestals and properly bonded to the building or site ground.
- Good—Use the raised floor structure as a ground grid. In this case, the floor must be designed as a ground grid with bolted down stringers and corrosion resistive plating (to provide low resistance and attachment points for connection to service entrance ground and HP computer equipment). The use of conductive floor tiles with this style of grid further enhances ground performance.

NOTE The structure needs to meet all applicable safety codes and be mechanically bonded to known good grounding points.

Best Practices

- Use a 2ft by 2ft grid.
- Flat braid is preferred over round wire.
- Exothermic welds are preferred over mechanical connections.
- All transformers mounted on the floor should have an X0 bond to floor.
- All air conditioning cabinets mounted on the floor with a bonding connection to the floor.
- A vertical building steel grounding point is preferred over long wire runs to electrical service entrance.
- Very short straps to the floor are preferred over excess lengths.

HP recommendations concerning the proper grounding of a raised floor or signal reference grid are closely aligned with other agencies such as the NEC and IEEE.

Figure 5-1 Raised Floor Metal Strip Ground System

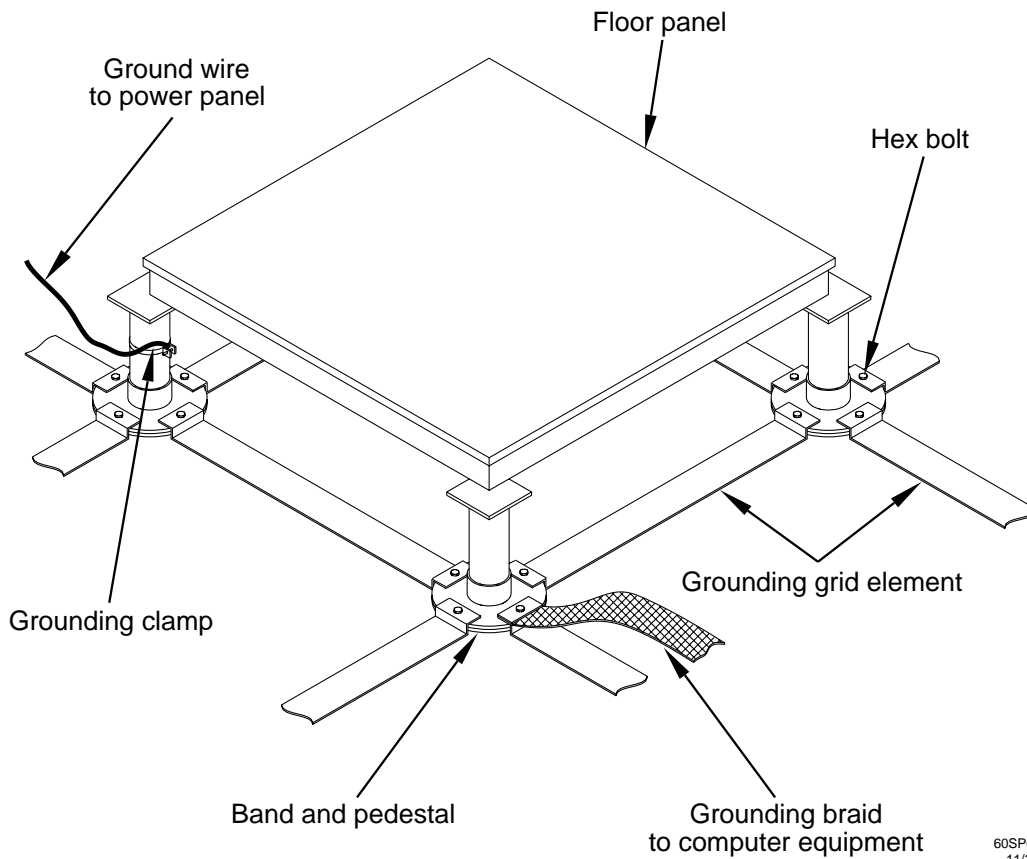

System Installation Guidelines

This section contains information about installation practices. Some common pitfalls are highlighted. Both power cable and data communications cable installations are discussed.

Wiring Connections Expansion and contraction rates vary among different metals. Therefore, the integrity of an electrical connection depends on the restraining force applied. Connections that are too tight compress or deform the hardware and causes it to weaken. This usually leads to high impedance causing circuit breakers to trip.

CAUTION Connections that are too loose have a high resistance that cause serious problems, such as erratic equipment operation. A high resistance connection overheats and sometimes causes fire or high temperatures that can destroy hard-to-replace components such as distribution panels or system bus bars.

Wiring connections must be properly torqued. Many equipment manufacturers specify the proper connection torque values for their hardware.

Ground connections must only be made on a conductive, nonpainted surface. Lockwashers must be used on all connections to prevent connection hardware from working loose.

Data Communications Cables Power transformers and heavy foot traffic create high energy fields. Route data communications cables away from these areas. Use shielded data communications cables that meet approved industry standards to reduce the effects of external fields. Data cables that are run externally to a metal fire enclosure must have a minimum fire rating of VW-1 or VW-4 or better.

Environmental Elements

The following environmental elements can affect a Superdome server installation:

- Computer room preparation
- Cooling requirements
- Humidity level
- Air conditioning ducts
- Dust and pollution control
- Electrostatic discharge (ESD) prevention
- Acoustics (noise reduction)
- Zinc whisker control

Computer Room Preparation

The following guidelines are recommended when preparing a computer room for a Superdome server system:

- Locate the computer room away from the exterior walls of the building to avoid the heat gain from windows and exterior wall surfaces.
- When exterior windows are unavoidable, use windows that are double- or triple-glazed and shaded to prevent direct sunlight from entering the computer room.
- Maintain the computer room at a positive pressure relative to surrounding spaces.
- Use a vapor barrier installed around the entire computer room envelope to restrain moisture migration.
- Caulk and vapor seal all pipes and cables that penetrate the envelope.
- Use at least a 12-inch raised floor system for the most favorable room air distribution system (underfloor distribution).

- Ensure a minimum ceiling height of 12 inches between the top of the server and the ceiling. Ensure all ceiling clips are in place.

Cooling Requirements

Air conditioning equipment requirements and recommendations are described in the following sections.

Basic Air Conditioning Equipment Requirements The cooling capacity of the installed air conditioning equipment for the computer room should be sufficient to offset the computer equipment dissipation loads, as well as any space envelope heat gain. This equipment should include:

- Air filtration
- Cooling or dehumidification
- Humidification
- Reheating
- Air distribution
- System controls adequate to maintain the computer room within the operating ranges listed in Table 5-1.

Table 5-1 Controlled Computer Room Environment Specifications

Temperature (dry bulb °C) ^a		Relative Humidity %; Noncondensing		Dew Point ^b	Rate of Chg (°C/hr, max)
Allowable ^{c,d}	Recommended ^e	Allowable ^d	Recommended ^e		
15 - 32 (59° to 90° F)	20 - 25 (68° to 77° F)	20 - 80	40 - 55	17	5

- a. Dry bulb temperature is the regular ambient temperature. Derate maximum dry bulb temperature 1°C/300 m above 900 m.
- b. Must be noncondensing environment.
- c. With installed media, the minimum temperature is 10°C and maximum relative humidity is limited to 80%. Specific media requirements may vary.
- d. Allowable: equipment design extremes as measured at the equipment inlet.
- e. Recommended: target facility design and operational range.

Lighting and personnel must also be included. For example, a person dissipates about 450 BTUs per hour while performing a typical computer room task.

At altitudes above 10,000 feet (3048 m), the lower air density reduces the cooling capability of air conditioning systems. If your facility is located above this altitude, the recommended temperature ranges may need to be modified.

Air Conditioning System Guidelines The following guidelines are recommended when designing an air conditioning system and selecting the necessary equipment:

- The air conditioning system serving the computer room should be capable of operating 24 hours a day, 365 days a year. It should also be independent of other systems in the building.
- Consider the long-term value of computer system availability, redundant air conditioning equipment, or capacity.
- The system should be capable of handling any future computer system expansion.
- Air conditioning equipment air filters should have a minimum rating of 45% (based on “ASHRA Standard 52-76, Dust Spot Efficiency Test”).
- Introduce only enough outside air into the system to meet building code requirements (for human occupancy) and to maintain a positive air pressure in the computer room.

Air Conditioning System Types The following three air conditioning system types are listed in order of preference:

- Complete self-contained package unit(s) with remote condenser(s). These systems are available with u, or down discharge and are usually located in the computer room.
- Chilled water package unit with remote chilled water plant. These systems are available with up or down discharge and are usually located in the computer room.
- Central station air handling units with remote refrigeration equipment. These systems are usually located outside the computer room.

Basic Air Distribution Systems A basic air distribution system includes supply air and return air.

An air distribution system should be zoned to deliver an adequate amount of supply air to the cooling air intake vents of the computer system equipment cabinets. Supply air temperature should be maintained within the following parameters:

- Ceiling supply system—From 55° F (12.8° C) to 60° F (15.6° C)
- Floor supply system—At least 60° F (15.6° C)

If a ceiling plenum return air system or a ducted ceiling return air system is used, the return air grille(s) in the ceiling should be located directly above the computer equipment cabinets.

The following three types of air distribution system are listed in order of recommendation:

- Underfloor air distribution system—Downflow air conditioning equipment located on the raised floor of the computer room uses the cavity beneath the raised floor as plenum for the supply air.

Return air from an underfloor air distribution system can be ducted return air (DRA) above the ceiling, as shown in Figure 5-3 on page 52.

Perforated floor panels (available from the raised floor manufacturer) should be located around the perimeter of the system cabinets. Supply air emitted through the perforated floor panels is then available near the cooling air intake vents of the computer system cabinets.

- Ceiling plenum air distribution system—Supply air is ducted into the ceiling plenum from upflow air conditioning equipment located in the computer room or from an air handling unit (remote).

The ceiling construction should resist air leakage. Place perforated ceiling panels (with down discharge air flow characteristics) around the perimeter of the system cabinets. The supply air emitted downward from the perforated ceiling panels is then available near the cooling air intake vents of the computer system cabinets.

Return air should be ducted back to the air conditioning equipment through the return air duct above the ceiling.

- Above ceiling ducted air distribution system—Supply air is ducted into a ceiling diffuser system from upflow air conditioning equipment located in the computer room or from an air handling unit (remote).

Return air from an above ceiling ducted air distribution system may be ducted return air (DRA) above the ceiling, as shown in Figure 5-5 on page 54, or ceiling plenum return air (CPRA), as shown in Figure 5-4 on page 53.

Adjust the supply air diffuser system grilles to direct the cooling air downward around the perimeter of the computer system cabinets. The supply air is then available near the cooling air intake vents of the computer system cabinets.

Air Conditioning System Installation All air conditioning equipment, materials, and installation must comply with any applicable construction codes. Installation of the various components of the air conditioning system must also conform to the air conditioning equipment manufacturer's recommendations.

Figure 5-3 on page 52 illustrates a typical computer room underfloor air distribution system (DRA).

Figure 5-4 on page 53 illustrates a typical computer room ceiling plenum air distribution system (CPRA).

Figure 5-5 on page 54 illustrates a typical computer room above ceiling ducted air distribution system (DRA).

Figure 5-2 **Typical Computer Room Raised Floor Layout**

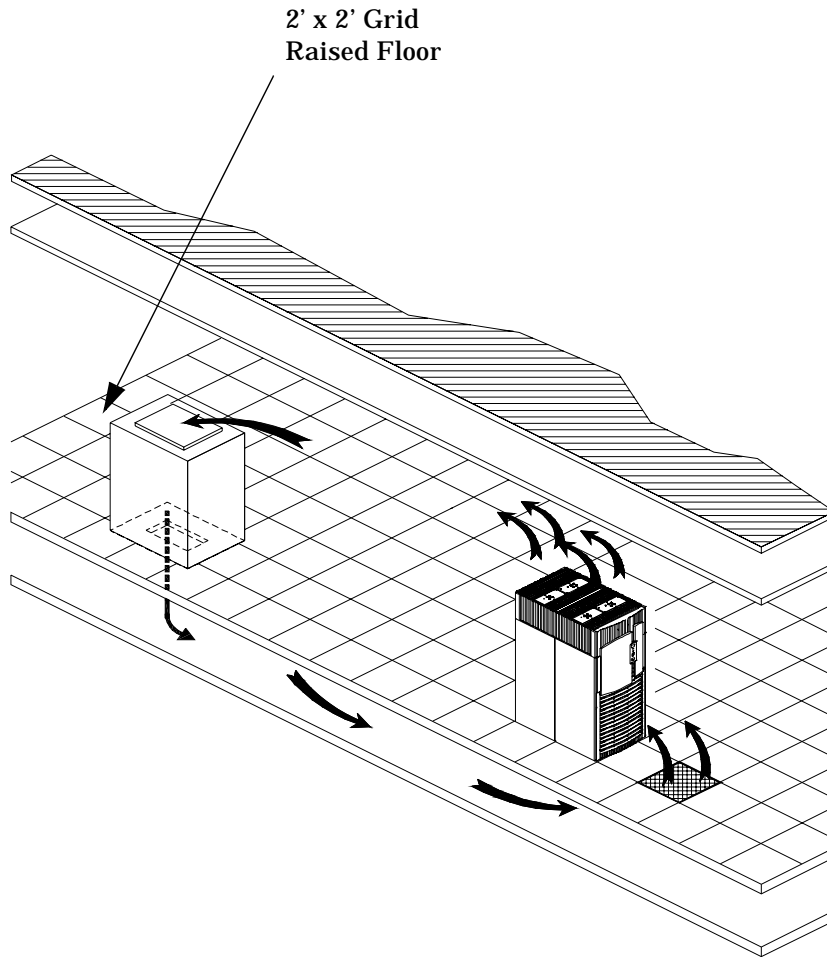

Figure 5-3 Underfloor Air Distribution System

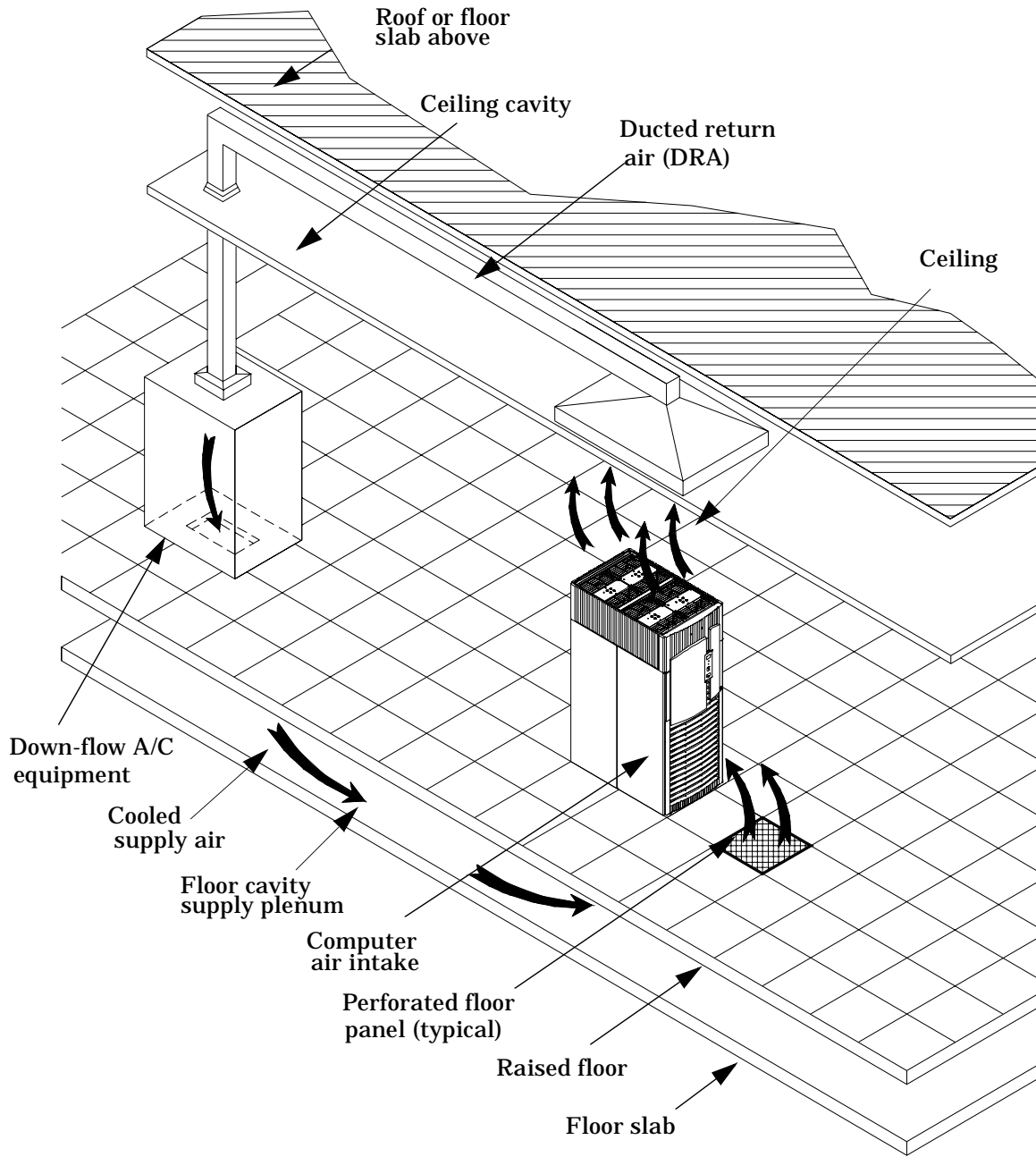

Figure 5-4 **Ceiling Plenum Air Distribution System**

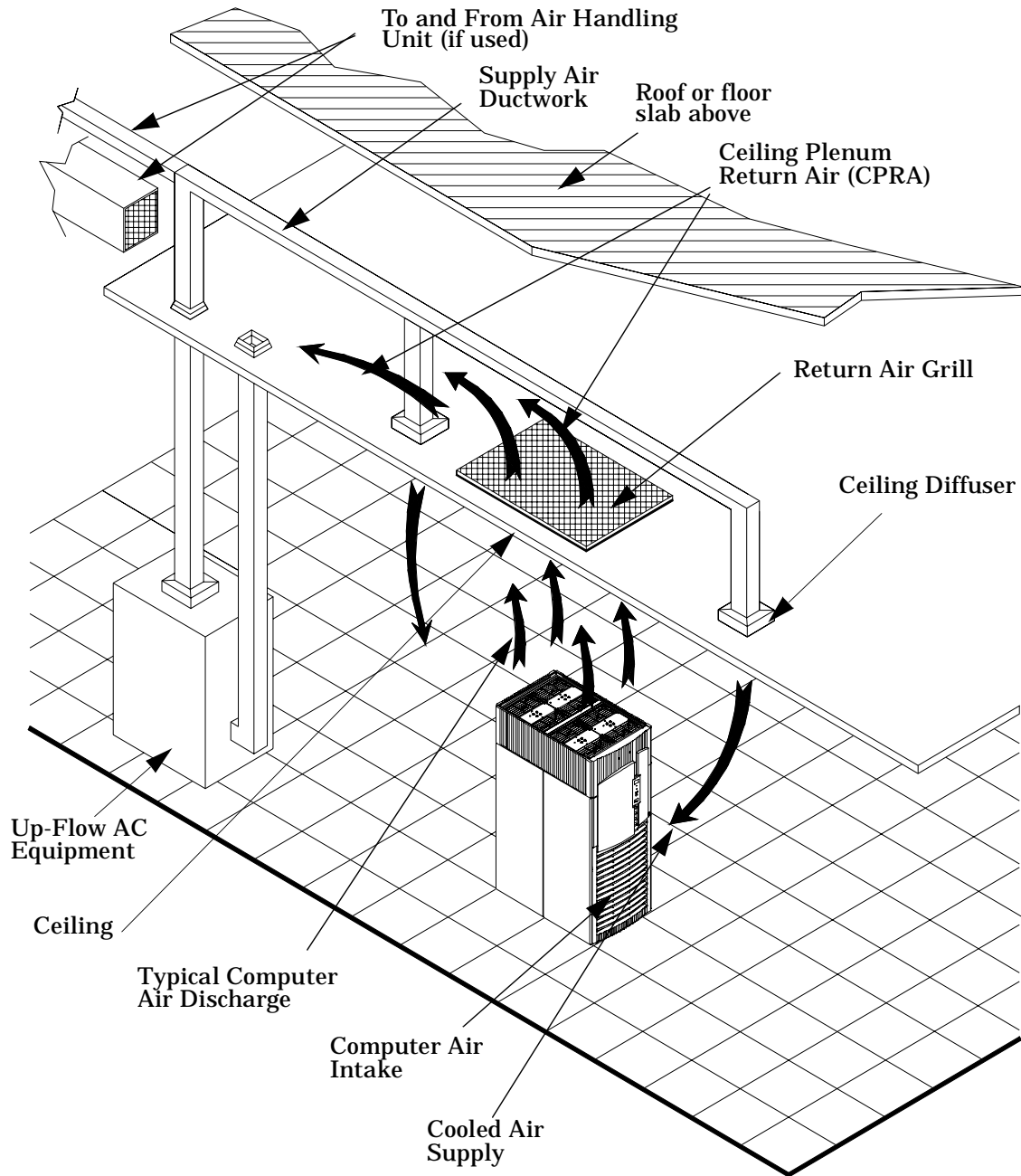
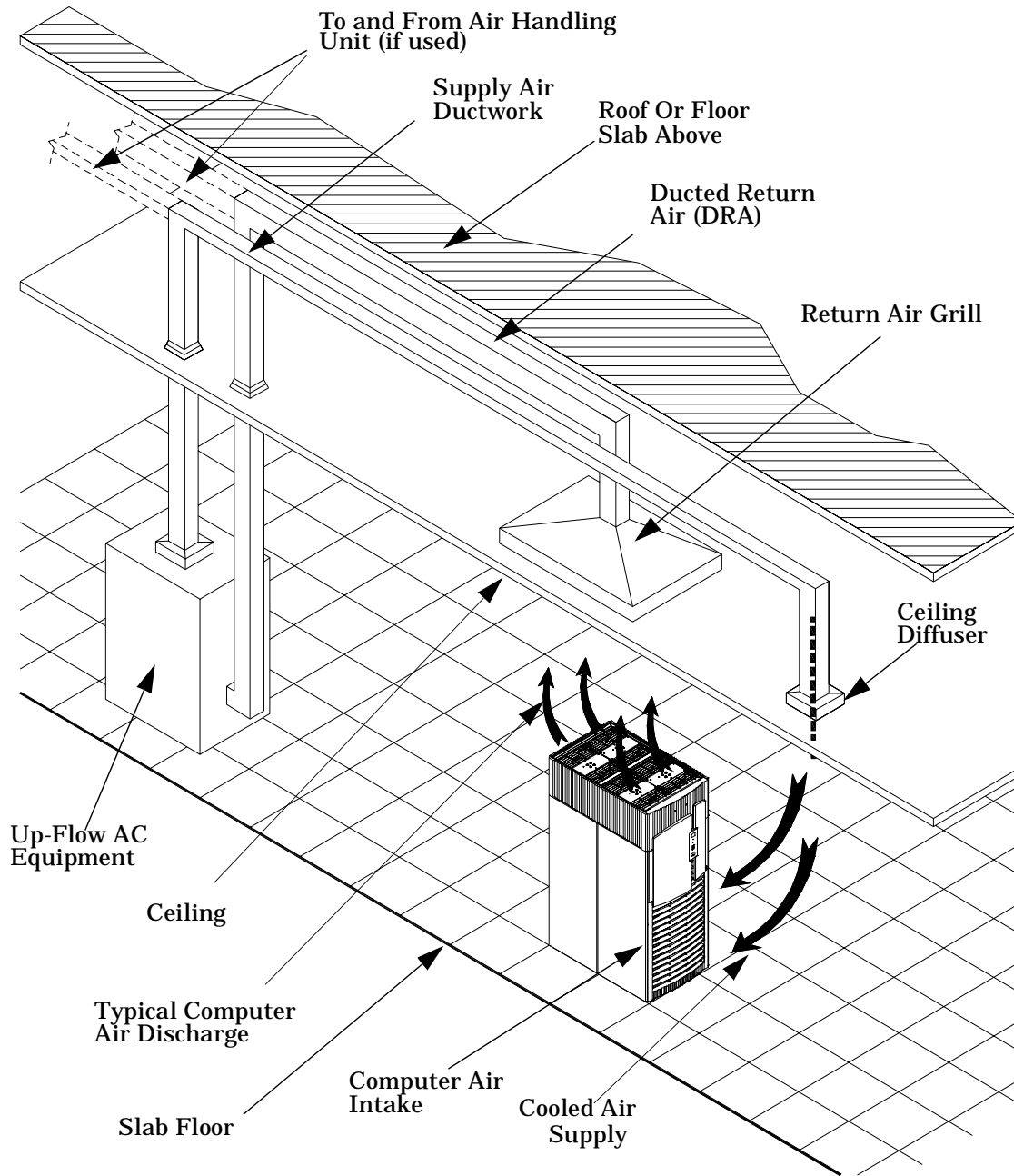

Figure 5-5 Above Ceiling Ducted Air



Humidity Level

Maintain proper humidity levels. High humidity causes galvanic actions to occur between some dissimilar metals. This eventually causes a high resistance between connections, leading to equipment failures. High humidity can also have an adverse affect on some magnetic tapes and paper media.

CAUTION Low humidity contributes to undesirably high levels of electrostatic charges. This increases the electrostatic discharge (ESD) voltage potential. ESD can cause component damage during servicing operations. Paper feed problems on high-speed printers are usually encountered in low-humidity environments.

Low humidity levels are often the result of the facility heating system and occur during the cold season. Most heating systems cause air to have a low humidity level, unless the system has a built-in humidifier.

Air Conditioning Ducts

Use separate computer room air conditioning duct work. If it is not separate from the rest of the building, it might be difficult to control cooling and air pressure levels. Duct work seals are important for maintaining a balanced air conditioning system and high static air pressure. Adequate cooling capacity means little if the direction and rate of air flow cannot be controlled because of poor duct sealing. Also, the ducts should not be exposed to warm air, or humidity levels may increase.

Dust and Pollution Control

Computer equipment can be adversely affected by dust and microscopic particles in the site environment.

Specifically, disk drives, tape drives, and some other mechanical devices can have bearing failures resulting from airborne abrasive particles. Dust may also blanket electronic components like printed circuit boards causing premature failure due to excess heat and/or humidity build up on the boards. Other failures to power supplies and other electronic components can be caused by metallically conductive particles. These metallic particles are conductive and can short circuit electronic components. Use every effort to ensure that the environment is as dust and particulant free as possible.

Smaller particles can pass though some filters and, over a period of time, possibly cause problems in mechanical parts. Small dust particles can be prevented from entering the computer room by maintaining its air conditioning system at a high static air pressure level.

Other sources of dust, metallic, conductive, abrasive, and/or microscopic particles can be present. Some sources of these particulants are:

- Subfloor shedding
- Raised floor shedding
- Ceiling tile shedding

These pollutants are not always visible to the naked eye. A good check to determine their possible presence is to check the underside of the tiles. The tile should be shiny, galvanized, and free from rust.

The computer room should be kept clean. The following guidelines are recommended:

- **Smoking**—Establish a no-smoking policy. Cigarette smoke particles are eight times larger than the clearance between disk drive read/write heads and the disk surface.
- **Printer**—Locate printers and paper products in a separate room to eliminate paper particulate problems.
- **Eating or drinking**—Establish a no-eating or drinking policy. Spilled liquids can cause short circuits in equipment such as keyboards.
- **Tile floors**—Use a dust-absorbent cloth mop rather than a dry mop to clean tile floors.

Special precautions are necessary if the computer room is near a source of air pollution. Some air pollutants, especially hydrogen sulfide (H₂S), are not only unpleasant but corrosive as well. Hydrogen sulfide damages wiring and delicate sound equipment. The use of activated charcoal filters reduces this form of air pollution.

Metallic Particulate Contamination

Metallic particulates can be especially harmful around electronic equipment. This type of contamination may enter the data center environment from a variety of sources, including but not limited to raised floor tiles, worn air conditioning parts, heating ducts, rotor brushes in vacuum cleaners or printer component wear. Because metallic particulates conduct electricity, they have an increased potential for creating short circuits in electronic equipment. This problem is exaggerated by the increasingly dense circuitry of electronic equipment.

Over time, very fine whiskers of pure metal can form on electroplated zinc, cadmium, or tin surfaces. If these whiskers are disturbed, they may break off and become airborne, possibly causing failures or operational interruptions. For over 50 years, the electronics industry has been aware of the relatively rare but possible threat posed by metallic particulate contamination. During recent years, a growing concern has developed in computer rooms where these conductive contaminants are formed on the bottom of some raised floor tiles.

Although this problem is relatively rare, it may be an issue within your computer room. Since metallic contamination can cause permanent or intermittent failures on your electronic equipment, Hewlett-Packard strongly recommends that your site be evaluated for metallic particulate contamination before installation of electronic equipment.

Electrostatic Discharge (ESD) Prevention

Static charges (voltage levels) occur when objects are separated or rubbed together. The voltage level of a static charge is determined by the following factors:

- Types of materials
- Relative humidity
- Rate of change or separation

Table 5-2 lists charge levels based on personnel activities and humidity levels.

Table 5-2 Effect of Humidity on ESD Charge Levels

Personnel Activity ^a	Humidity ^b and Charge Levels (volts) ^c			
	26%	32%	40%	50%
Walking across a linoleum floor	6,150	5,750	4,625	3,700
Walking across a carpeted floor	18,450	17,250	13,875	11,100
Getting up from a plastic chair	24,600	23,000	18,500	14,800

a. Source: B.A.Unger, Electrostatic Discharge Failures of Semiconductor Devices (Bell Laboratories, 1981)

b. For the same relative humidity level, a high rate of airflow produces higher static charges than a low airflow rate.

c. Some data in this table has been extrapolated.

Static Protection Measures Follow these precautions to minimize possible ESD-induced failures in the computer room:

- Install conductive flooring (conductive adhesive must be used when laying tiles).
- Use conductive wax (if waxed floors are necessary).
- Ensure that all equipment and flooring are properly grounded and are at the same ground potential.

- Use conductive tables and chairs.
- Use a grounded wrist strap (or other grounding method) when handling circuit boards.
- Store spare electronic modules in antistatic containers.
- Maintain recommended humidity level and airflow rates in the computer room.

Acoustics

Computer equipment and air conditioning blowers cause computer rooms to be noisy. Ambient noise level in a computer room can be reduced as follows:

- Dropped ceiling—Cover with a commercial grade of fire-resistant, acoustic rated, fiberglass ceiling tile.
- Sound deadening—Cover the walls with curtains or other sound deadening material.
- Removable partitions—Use foam rubber models for most effectiveness.

Site Guidelines

This section describes facility characteristics and provides guidelines for preparing the computer room.

- “Facility Characteristics” on page 58 discusses architectural issues.
- “Space Requirements” on page 61 discusses the amount of floor space required by the components.

NOTE Refer to Appendix C for templates to aid in locating caster contact area and caster/leveling foot centers. Templates are also provided to locate required cutouts for cable routing.

Facility Characteristics

This section contains information about facility characteristics that must be considered for the installation or operation of a Superdome server. Facility characteristics are:

- Floor loading
- Windows
- Altitude effects

Floor Loading

The computer room floor must be able to support the total weight of the installed computer system as well as the weight of the individual cabinets as they are moved into position.

Floor loading is usually not an issue in non-raised-floor installations. The information presented in this section is directed toward raised-floor installations.

NOTE Any floor system under consideration for a Superdome server installation should be verified by an appropriate floor system consultant.

Raised-Floor Loading Raised-floor loading is a function of the manufacturer’s load specification and the positioning of the equipment relative to the raised-floor grid. While Hewlett-Packard cannot assume responsibility for determining the suitability of a particular raised-floor system, information and illustrations are provided for the customer or local agencies to determine installation requirements.

The following guidelines are recommended:

- Because many raised-floor systems do not have grid stringers between floor stands, the lateral support for the floor stands depends on adjacent panels being in place. To avoid compromising this type of floor system while gaining under floor access, remove only one floor panel at a time.
- Larger floor grids (bigger panels) are generally rated for lighter loads.

CAUTION Do not install any raised-floor system until you have carefully examined it to verify that it is adequate to support the appropriate installation.

Floor-Loading Terms Table 5-3 defines floor-loading terms.

Table 5-3 Floor-Loading Terms

Term	Definition
Dead load	Weight of the raised-panel floor system, including the understructure. Expressed in lb/ft ² (kg/m ²).
Live load	Load the floor system can safely support. Expressed in lb/ft ² (kg/m ²).
Concentrated load	Load a floor panel can support on a 1-in ² (6.45 cm ²) area at the panel's weakest point (typically the center of the panel), without the surface of the panel deflecting more than a predetermined amount.
Ultimate load	Maximum load (per floor panel) the floor system can support without failure. Failure expressed by floor panel(s) breaking or bending. Ultimate load is usually stated as load per floor panel.
Rolling load	Load a floor panel can support (without failure) when a wheel of specified diameter and width is rolled across the panel.
Average floor load	Computed by dividing total equipment weight by the area of its footprint. This value is expressed in lb/ft ² (kg/m ²).

Average Floor Loading The average floor load value, defined in Table 5-4, is not appropriate for addressing raised-floor ratings at the floor grid spacing level. However, it is useful for determining floor-loading at the building level, such as the area of solid floor or span of raised-floor tiles covered by the Superdome server footprint.

Typical Raised-Floor Site This section contains an example of a computer room raised-floor system that is satisfactory for the installation of a Superdome server.

Based on specific information provided by Hewlett-Packard, Tate Access Floors has approved its Series 800 all-steel access floor with bolt-together stringers and 24 in. (61.0 cm) by 24 in. (61.0 cm) floor panels.

Due to the large amount of floor panel material that must be removed for the purpose of routing cables, this particular floor must be braced as shown in Figure 5-6.

In the event that the flooring is being replaced or a new floor is being installed, Tate Access Floors recommends its Series 1250 all-steel access floor with bolt-together stringers and 24 in. (61.0 cm) by 24 in. (61.0 cm) floor panels be used to support the Superdome installation.

Figure 5-6 Tate Series 800 Floor Bracing

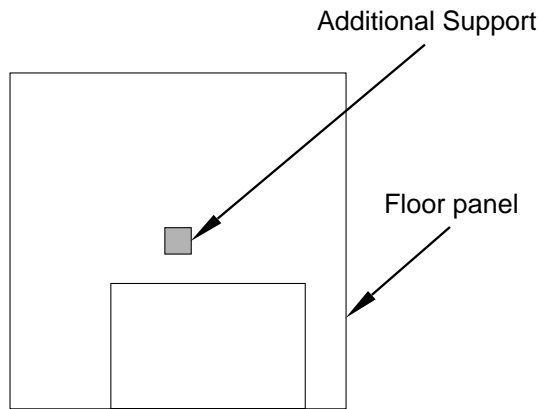

60SP039A
 5/9/00

NOTE If the specific floor being evaluated or considered is other than a Tate Series 800 floor, the specific floor manufacturer must be contacted to evaluate the floor being used.

Table 5-4 lists specifications for the Tate Access Floors Series 800 raised-floor system.

Table 5-4 Tate Series 800 Raised-Floor Tile Specifications

Item	Rating
Dead load	7 lb/ft ² (34.2 kg/m ²)
Live load	313 lb/ft ² (1528.3 kg/m ²)
Concentrated load ^a	1250 lb (567 kg)
Ultimate load	4000 lb (1814 kg) per panel
Rolling load	400 lb (181 kg)
Average Tile load	500 lb (227 kg)

a. With 0.08 in (0.2 cm) of span maximum deflection

Windows

Avoid housing computers in a room with windows. Sunlight entering a computer room may cause problems. Magnetic tape storage media is damaged if exposed to direct sunlight. Also, the heat generated by sunlight places an additional load on the cooling system.

Space Requirements

This section contains information about space requirements for a Superdome server. This data should be used as the basic guideline for space plan developments. Other factors, such as airflow, lighting, and equipment space requirements, must also be considered.

Delivery Space Requirements

There should be enough clearance to move equipment safely from the receiving area to the computer room. Permanent obstructions, such as pillars or narrow doorways, can cause equipment damage.

Delivery plans should include the possible removal of walls or doors. The physical dimensions for applicable computers and peripheral equipment are summarized in Appendix A.

Operational Space Requirements

Other factors must be considered along with the basic equipment dimensions. Reduced airflow around equipment causes overheating, which can lead to equipment failure. Therefore, the location and orientation of air conditioning ducts, as well as airflow direction, are important. Obstructions to equipment intake or exhaust airflow must be eliminated.

The location of lighting fixtures and utility outlets affects servicing operations. Plan equipment layout to take advantage of lighting and utility outlets. Do not forget to include clearance for opening and closing equipment doors.

Clearance around and above the cabinets must be provided for proper cooling airflow through the equipment.

The service area space requirements, outlined in Appendix C, are minimum dimensions. If other equipment is located so that it exhausts heated air near the cooling air intakes of the computer system cabinets, larger space requirements are needed to keep ambient air intake to the computer system cabinets within the specified temperature and humidity ranges.

Space planning should also include the possible addition of equipment or other changes in space requirements. Equipment layout plans should also include provisions for the following:

- Channels or fixtures used for routing data cables and power cables
- Access to air conditioning ducts, filters, lighting, and electrical power hardware
- Power conditioning equipment
- Cabinets for cleaning materials
- Maintenance area and spare parts

Floor Plan Grid

The floor plan grid is used to plan the location of equipment in the computer room. In addition to its use for planning, the floor plan grid should also be used when planning the locations of the following items:

- Air conditioning vents
- Lighting fixtures
- Utility outlets
- Doors
- Access areas for power wiring and air conditioning filters
- Equipment cable routing

Copies of the floor plan grid are located in Appendix C.

Equipment Footprint Templates

Equipment footprint templates are provided in Appendix C to show basic equipment dimensions and space requirements for servicing. Be sure to use the appropriate templates for the equipment that is to be installed.

The service areas shown on the template drawings are lightly shaded.

Removable copies of the equipment footprint templates are located in Appendix C. They should be used with the floor plan grid to define the location of the equipment that will be installed in your computer room.

NOTE Photocopying typically changes the scale of drawings copied. If any templates are copied, then all templates and floor plan grids must also be copied.

6 Pre-Installation Survey

This chapter provides a pre-installation survey information packet consisting of an information form and checklists to be used to evaluate a computer facility. The checklists information sheets and information forms should be filled out by the customer and a Hewlett-Packard representative.

Pre-Installation Survey Content

The site pre-installation survey information is designed to identify problems that might occur before, during, or after the installation of the system. It contains the following items:

- Pre-installation checklists—Verify the customer site is ready for the equipment installation.
- Pre-installation survey information sheets—List customer name, address, and corresponding Hewlett-Packard sales personnel.
- Pre-installation survey information forms—List delivery information and special instructions.

Typical Installation Schedule

The following schedule lists the sequence of events for a typical system installation:

- 60 days before installation
 - Floor plan design completed and mailed to Hewlett-Packard
- 30 days before installation
 - Primary power and air conditioning installation completed
 - Telephone and data cables installed
 - Fire protection equipment installed
 - Major facility changes completed
 - Special delivery requirements defined
 - Site inspection survey completed
 - Delivery survey completed
 - Signed copy of the site inspection and delivery survey mailed to Hewlett-Packard
 - Site inspection and pre-delivery coordination meeting arranged with a Hewlett-Packard representative to review the inspection checklist and arrange an installation schedule.
- 7 days before installation
 - Final check made with a Hewlett-Packard customer engineer to resolve any last-minute problems

Site Inspection

Table 6-1 contains a sample of the Customer and Hewlett-Packard information required.

Table 6-2 contains a sample site inspection checklist.

IMPORTANT Ensure that the customer is aware of the iCOD email requirements. That is, each bootable partition requires a connection to the internet to send email to notify Hewlett-Packard that the customer has allocated additional CPUs beyond the amount initially purchased. Each bootable partition must be configured to perform this operation.

NOTE Table 6-1 and Table 6-2 are provided as examples only. To ensure use of the current information specific to your site preparation, refer to the Site Readiness Review Section of the Deployment Manager's Handbook.

Table 6-1 Customer and Hewlett-Packard Information

Customer Information	
Name:	Phone No:
Street Address:	City or Town:
State or Province:	Country
Zip or postal code:	
Primary customer contact:	Phone No.:
Secondary customer contact:	Phone No.:
Traffic coordinator:	Phone No.:
Hewlett-Packard information	
Sales representative	Order No:
Representative making survey	Date:
Scheduled delivery date	

NOTE To ensure compliance with item 10 of Table 6-2, provide a copy of Appendix D to the customer to use a worksheet to identify required names and addresses for the LAN.

Table 6-2 Site Inspection Checklist

Please check either Yes or No. If No, include comment or date				Comment or Date
Computer room				
No.	Area or condition	Yes	No	
1.	Is there a completed floor plan?			
2.	Is there adequate space for maintenance needs? Front 42 in (106 cm) min., 48 in (121 cm) recommended. Rear 32 in (81 cm) min., 36 in (91cm) recommended			
3.	Is access to the site or computer room restricted?			
4.	Is the computer room structurally complete? Expected date of completion?			
5.	Is a raised floor installed and in good condition? What is the floor to ceiling height? [7.5 ft (228 cm) minimum]			
6.	Is the raised floor adequate for equipment loading?			
7.	Are there channels or cutouts for cable routing?			
8.	Is there a remote console telephone line available with an RJ11 jack?			
9.	Is a telephone line available?			
9a.	Is the customer aware of the iCOD email requirements? Each bootable partition requires a connection to the internet to send email to notify Hewlett-Packard that the customer has allocated additional CPUs beyond the amount initially purchased. Each bootable partition must be configured to perform this operation. For more details, go to http://superdome.hp.com and click on the iCOD link.			
10.	Are customer supplied peripheral and LAN cables available and of the proper type?			

Table 6-2 Site Inspection Checklist (Continued)

Please check either Yes or No. If No, include comment or date				Comment or Date
11.	Are floor tiles in good condition and properly braced?			
12.	Metallic particulate test required.			
Power and lighting				
No.	Area or condition	Yes	No	
13.	Are lighting levels adequate for maintenance?			
14.	Are there ac outlets available for servicing needs? (i.e. vacuuming)			
15.	Does the input voltage correspond to equipment specifications?			
15A	Is dual source power used? If so, identify type(s) and evaluate grounding.			
16	Does the input frequency correspond to equipment specifications?			
17.	Are lightning arrestors installed inside the building?			
18.	Is power conditioning equipment installed?			
19.	Is there a dedicated branch circuit for equipment?			
20.	Is the dedicated branch circuit less than 250 feet (72.5 meters)?			
21.	Are the input circuit breakers adequate for equipment loads?			
Safety				
No.	Area or condition	Yes	No	
22.	Is there an emergency power shut-off switch?			
23.	Is there a telephone available for emergency purposes?			
24.	Is there a fire protection system in the computer room?			
25.	Is antistatic flooring installed?			

Table 6-2 Site Inspection Checklist (Continued)

Please check either Yes or No. If No, include comment or date				Comment or Date
26.	Are there any equipment servicing hazards (loose ground wires, poor lighting, etc.)?			
Cooling				
No.	Area or condition	Yes	No	
27.	Can cooling be maintained between 68° and 77° (20° and 25° C)?			
28.	Can temperature changes be held to 9° (5 ° C) per hour?			
29.	Can humidity level be maintained between 40% and 55%?			
30.	Are air conditioning filters installed and clean?			
Storage				
No.	Area or condition	Yes	No	
31.	Are cabinets available for tape and disc media?			
32.	Is shelving available for documentation?			
Training				
No.	Area or Condition			
33	Are personnel enrolled in the System Administrator's Course?			
34	Is on-site training required?			

Delivery Survey

The delivery survey form shown in Figure 6-1 on page 71 and Figure 6-2 on page 72 lists delivery or installation requirements. If any of the items on the list apply, enter the appropriate information in the areas provided on the form.

Special instructions or recommendations should be entered on the Special Instructions or Recommendations form. Following are examples of special instructions or issues:

- Packaging restrictions at the facility, such as size and weight limitations
- Special delivery procedures
- Special equipment required for installation, such as tracking or hoists
- What time the facility is available for installation (after the equipment is unloaded)

- Special security requirements applicable to the facility, such as security clearance

Figure 6-1 Delivery Survey (Part 1)

DELIVERY CHECKLIST	
DOCK DELIVERY	
Is dock large enough for a semitrailer? Yes _____ No _____	
Circle the location of the dock and give street name if different than address.	
<div style="display: flex; justify-content: space-between; align-items: center;">West<div style="border: 1px solid black; width: 150px; height: 80px; background-color: #cccccc; margin: 0 auto;"></div>East</div> <p style="text-align: center;">North</p> <p style="text-align: center;">South</p>	
STREET DELIVERY	
Circle the location of access door and list street name if different than address.	
<div style="display: flex; justify-content: space-between; align-items: center;">West<div style="border: 1px solid black; width: 150px; height: 80px; background-color: #cccccc; margin: 0 auto;"></div>East</div> <p style="text-align: center;">North</p> <p style="text-align: center;">South</p>	
List height _____ and width _____ of access door.	
List special permits (if required) for street delivery.	
Permit type:	Agency obtained from:

60SP018A
12/7/99

Figure 6-2 **Delivery Survey (Part 2)**

ELEVATOR

Fill in the following information if an elevator is required to move equipment.

Capacity (lb or kg) _____

Depth _____

Height _____

Width _____

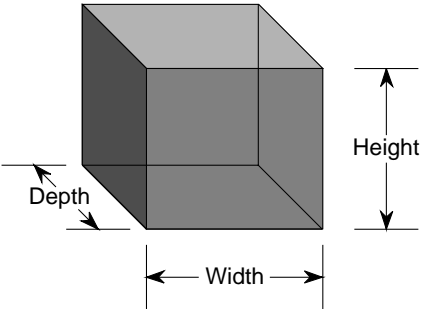

STAIRS

Please list number of flights and stairway dimensions.

Number of flights _____

Width _____

Width _____

Number of flights _____

Width _____

Width _____

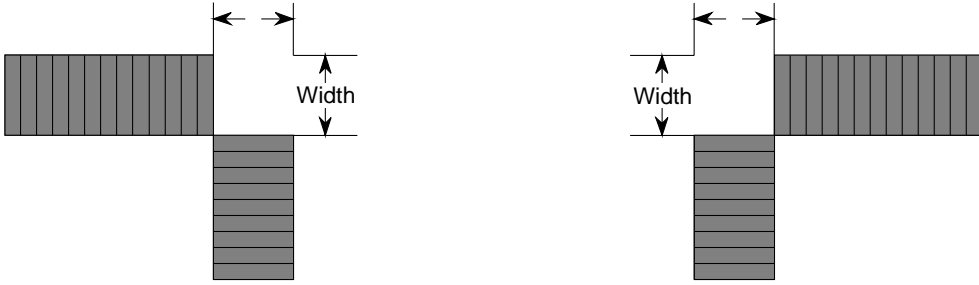

60SP019A
11/24/99

A Templates

This appendix contains blank floor plan grids and equipment templates. Combine the necessary number of floor plan grid sheets to create a scaled version of the computer room floor plan.

Figure A-1 illustrates the locations required for the cable cutouts.

Figure A-2 on page 78 illustrates the overall dimensions required for an hp Integrity Superdome SD32 or an hp 9000 Superdome SD32 system.

Figure A-3 on page 79 illustrates the overall dimensions required for a SD64 system.

Figure A-1 Cable Cutouts and Caster Locations

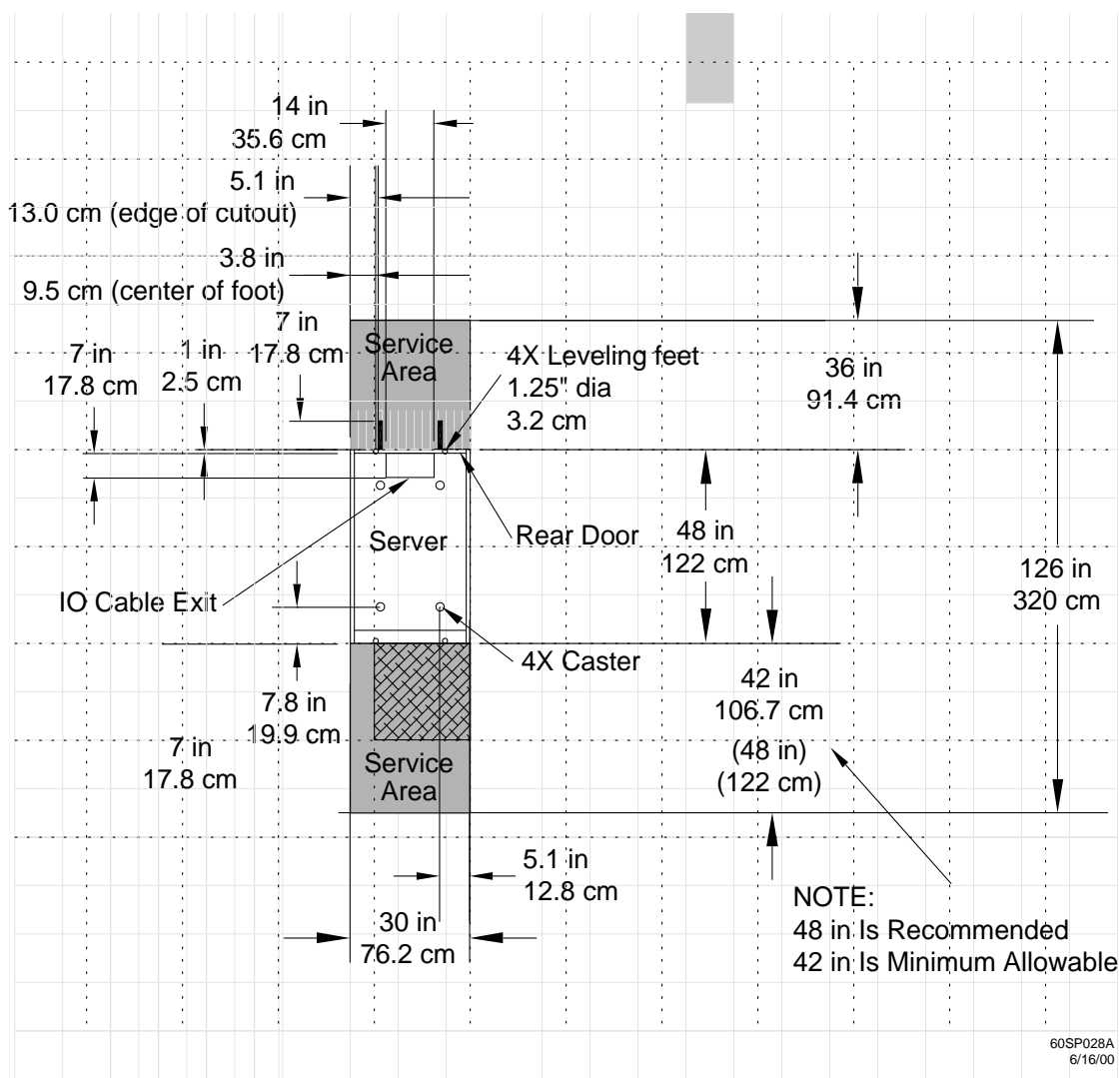
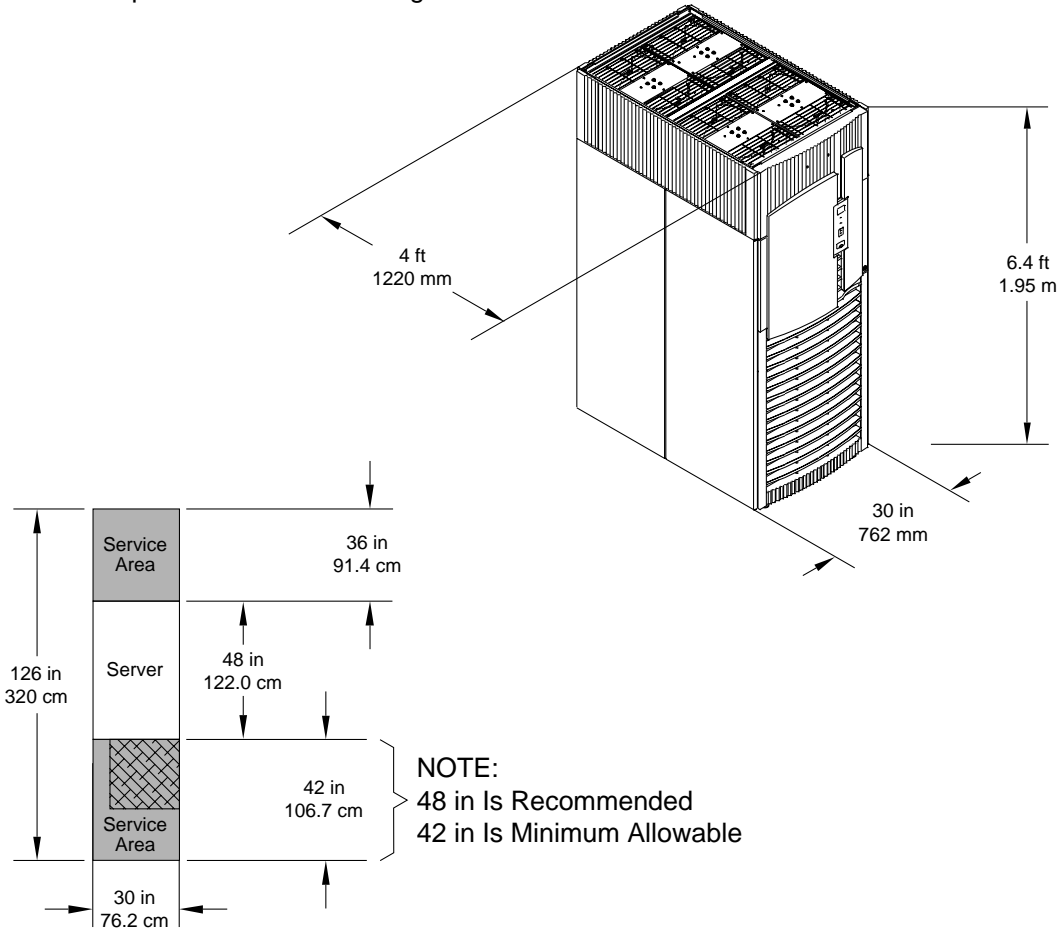

Figure A-2 SD16 /SD32 Space Requirements

NOTE:
12" Minimum Clearance Required
Between Top Of Cabinet and Ceiling



60SP021A
4/18/00

Figure A-3 SD64 Space Requirements

NOTE:
12" Minimum Clearance Required
Between Top Of Cabinet and Ceiling

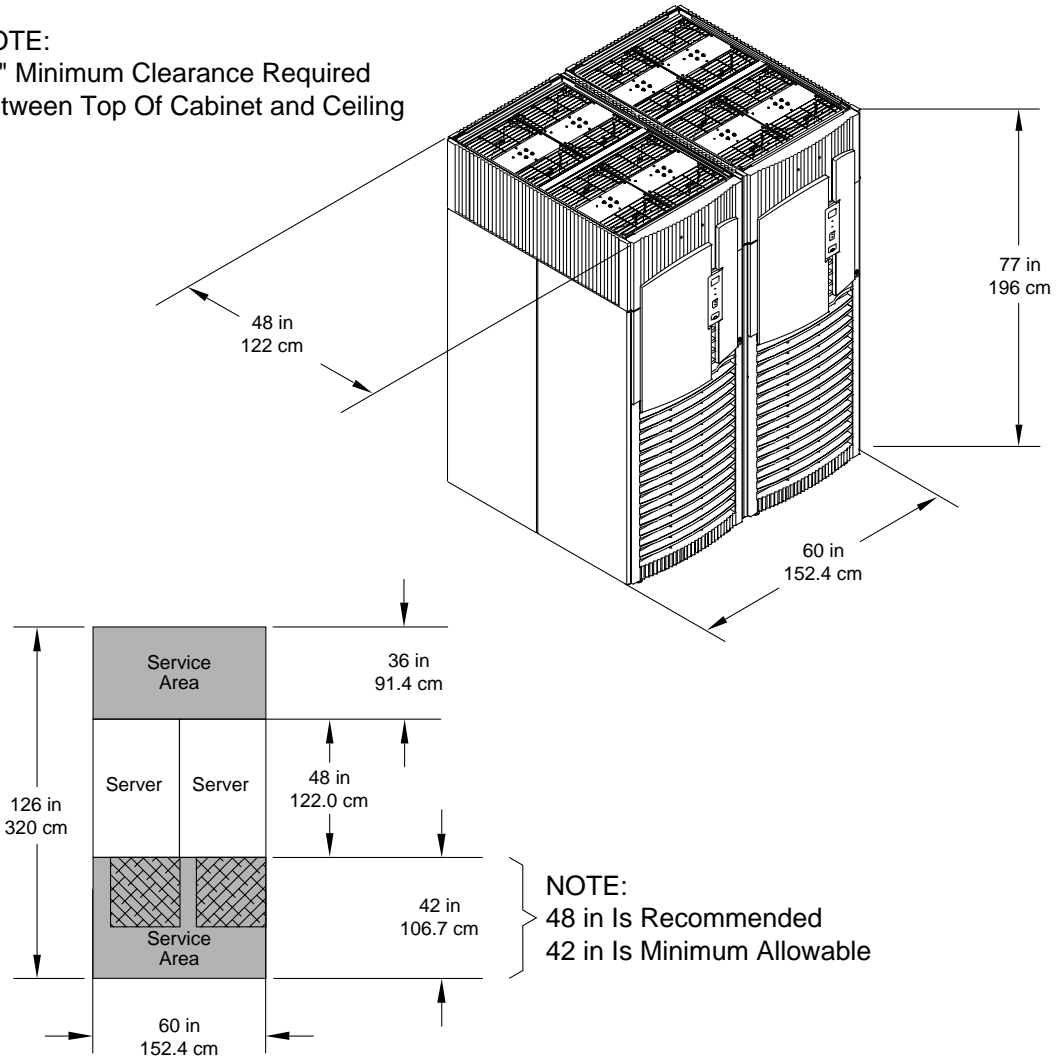

60SP022A
4/28/00

Equipment Footprint Templates

Equipment footprint templates are drawn to the same scale as the floor plan grid (1/4 inch = 1 foot). These templates are provided to show basic equipment dimensions and space requirements for servicing.

The service areas shown on the template drawings are lightly shaded.

The equipment templates should be used with the floor plan grid to define the location of the equipment that will be installed in your computer room.

NOTE Photocopying typically changes the scale of copied drawings. If any templates are copied, then all templates and floor plan grids must also be copied.

Computer Room Layout Plan

Use the following procedure to create a computer room layout plan:

- Step 1.** Remove several copies of the floor plan grid.
- Step 2.** Cut and join them together (as necessary) to create a scale model floor plan of your computer room.
- Step 3.** Remove a copy of each applicable equipment footprint template.
- Step 4.** Cut out each template selected in Step 3; then place it on the floor plan grid created in Step 2.
- Step 5.** Position pieces until the desired layout is obtained; then fasten the pieces to the grid. Mark locations of computer room doors, air-conditioning floor vents, utility outlets, and so on.

NOTE Attach a reduced copy of the completed floor plan to the site survey located in Chapter 4, "Pre-installation Survey." Hewlett-Packard field engineers use this floor plan during equipment installation.

SD32, SD64, and I/O Expansion Cabinet Templates

Scale: 1/4 inch = 1 foot

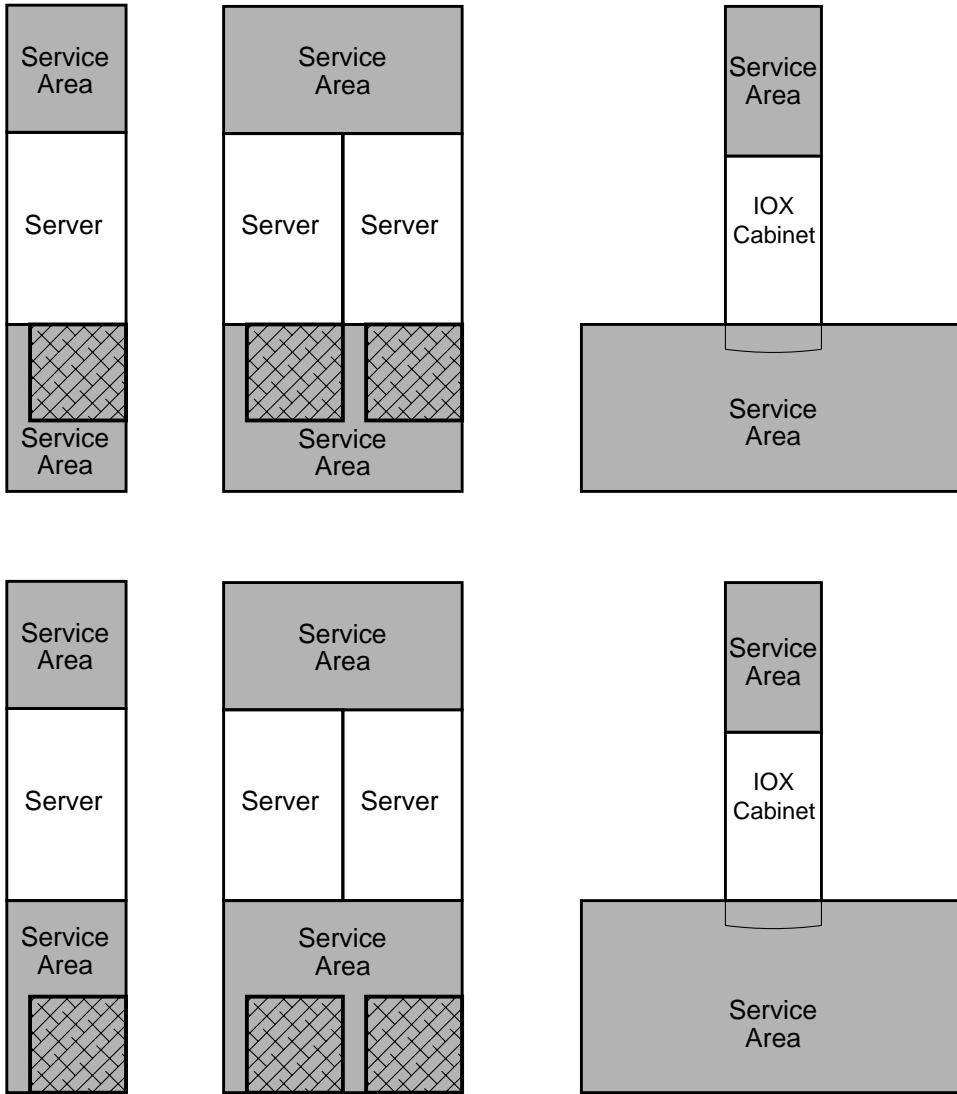

60SP017A
 7/16/00

SD32, SD64, and I/O Expansion Cabinet Templates

Scale: 1/4 inch = 1 foot

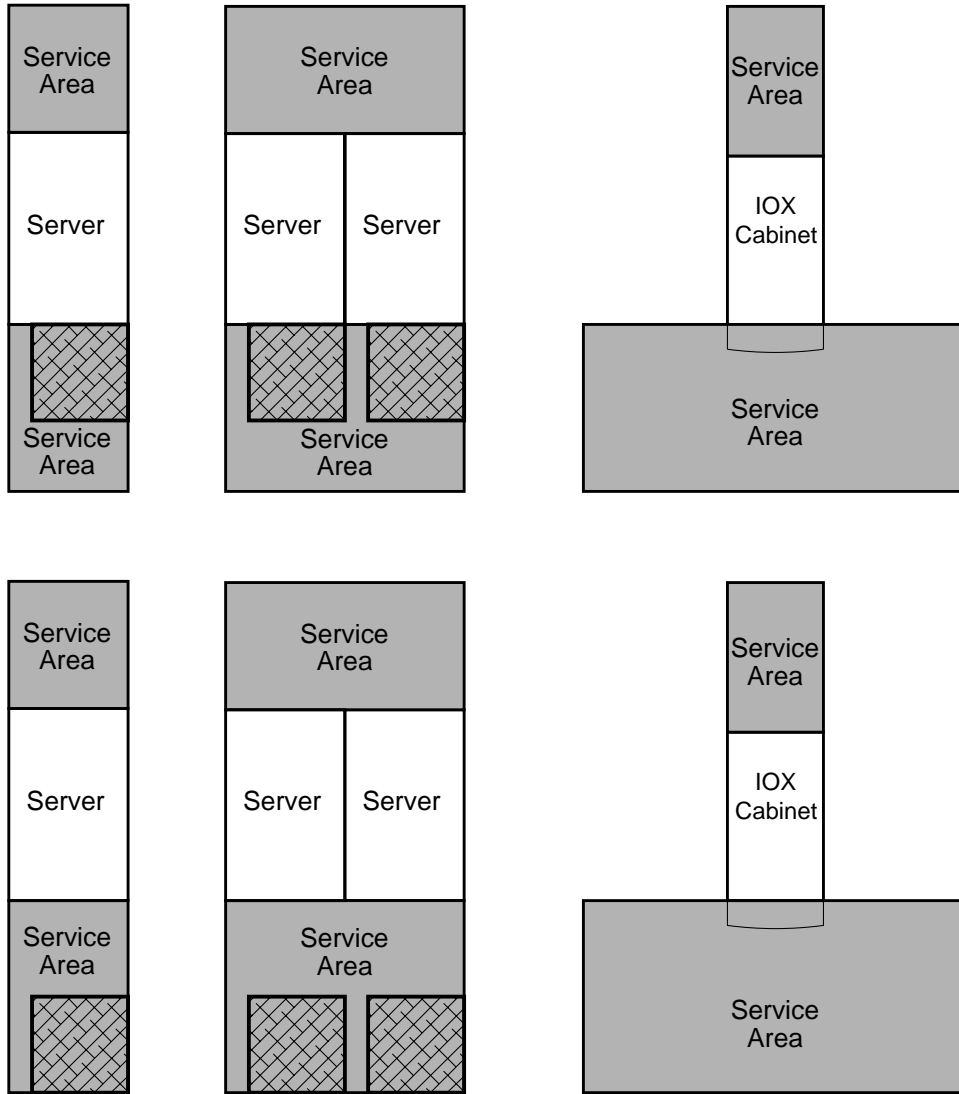

60SP017A
7/16/00

SD32, SD64, and I/O Expansion Cabinet Templates

Scale: 1/4 inch = 1 foot

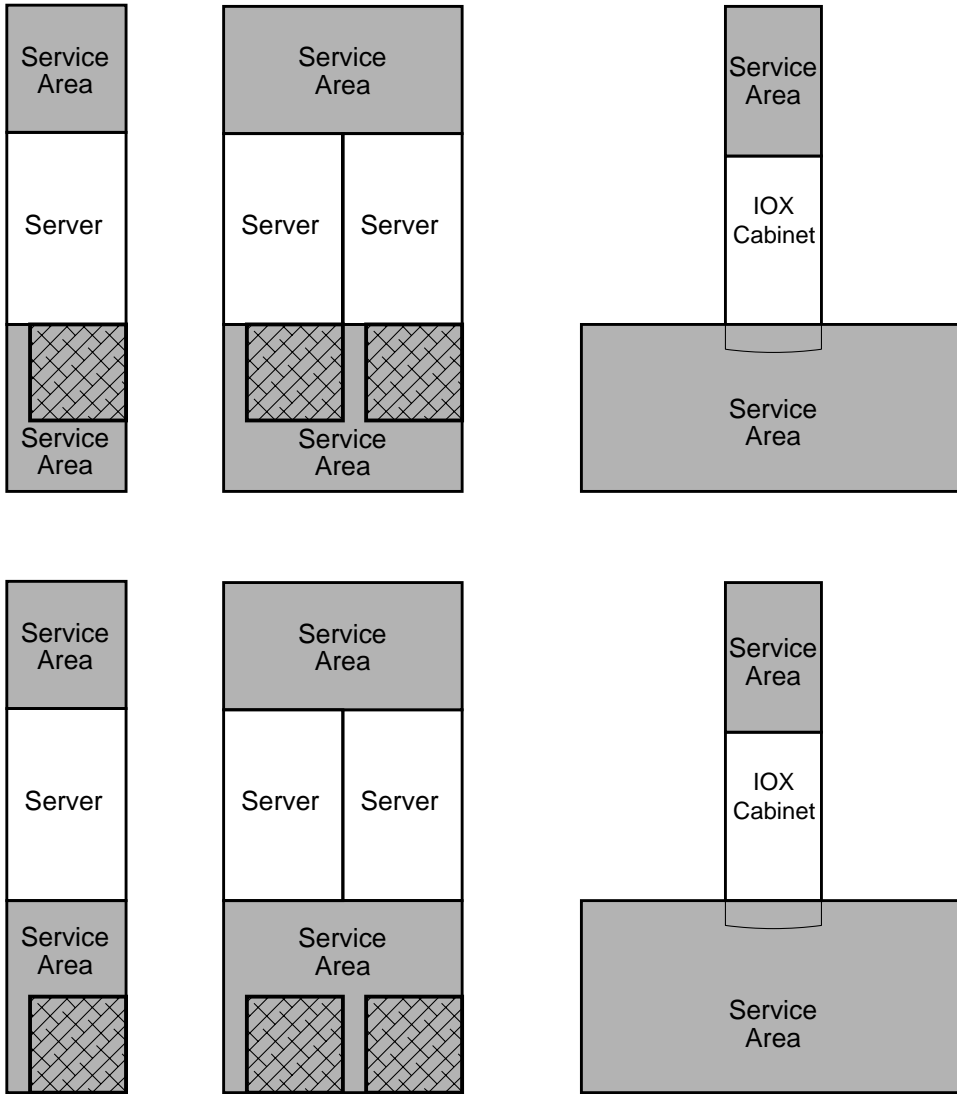

60SP017A
7/16/00

SD32, SD64, and I/O Expansion Cabinet Templates

Scale: 1/4 inch = 1 foot

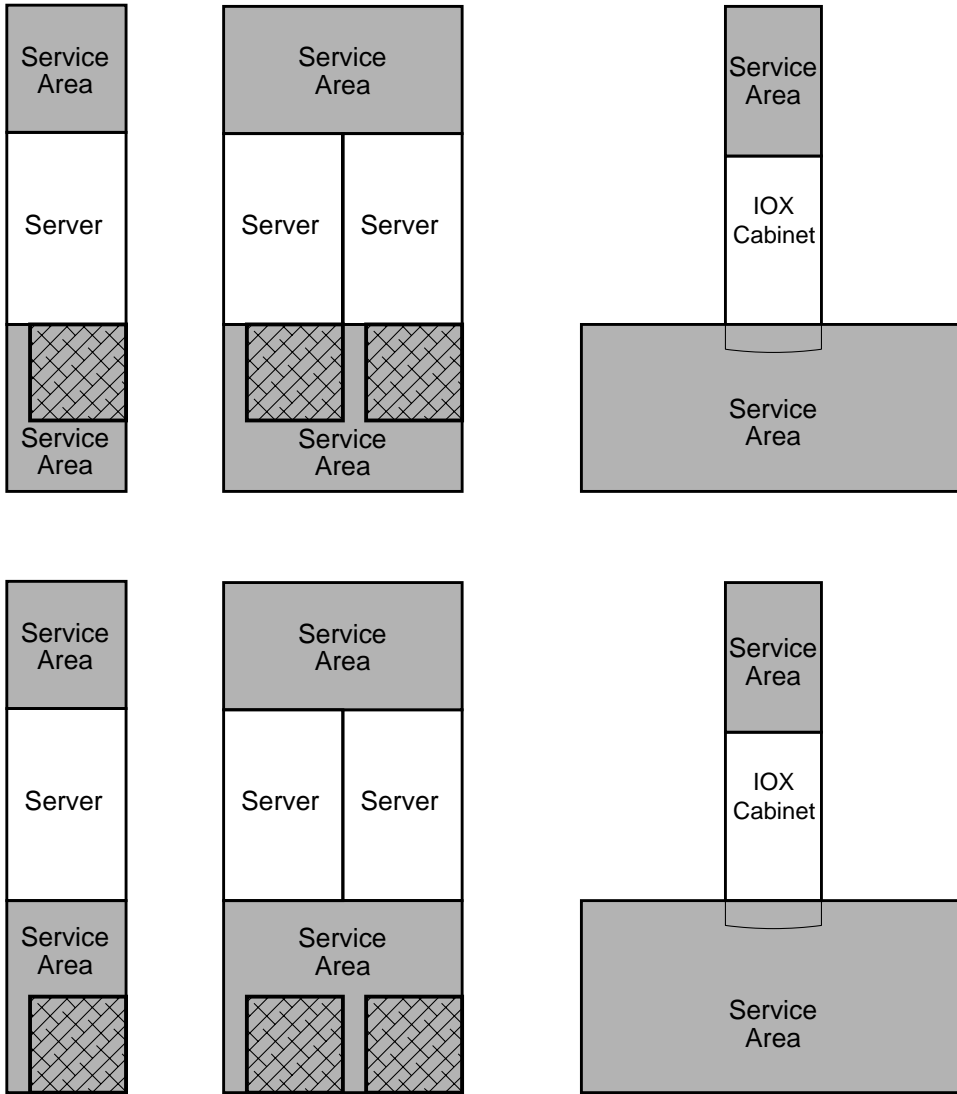

60SP017A
7/16/00

SD32, SD64, and I/O Expansion Cabinet Templates

Scale: 1/4 inch = 1 foot

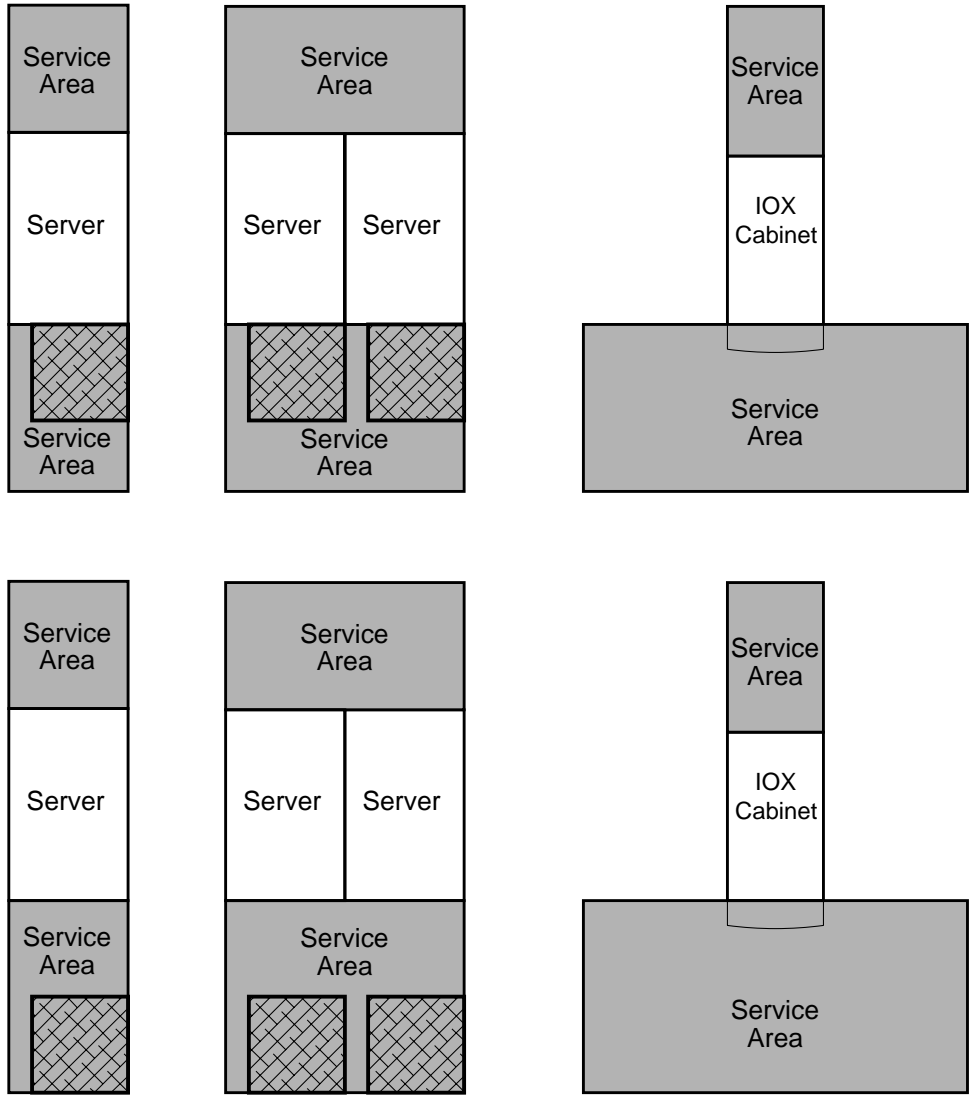

60SP017A
7/16/00

SD32, SD64, and I/O Expansion Cabinet Templates

Scale: 1/4 inch = 1 foot

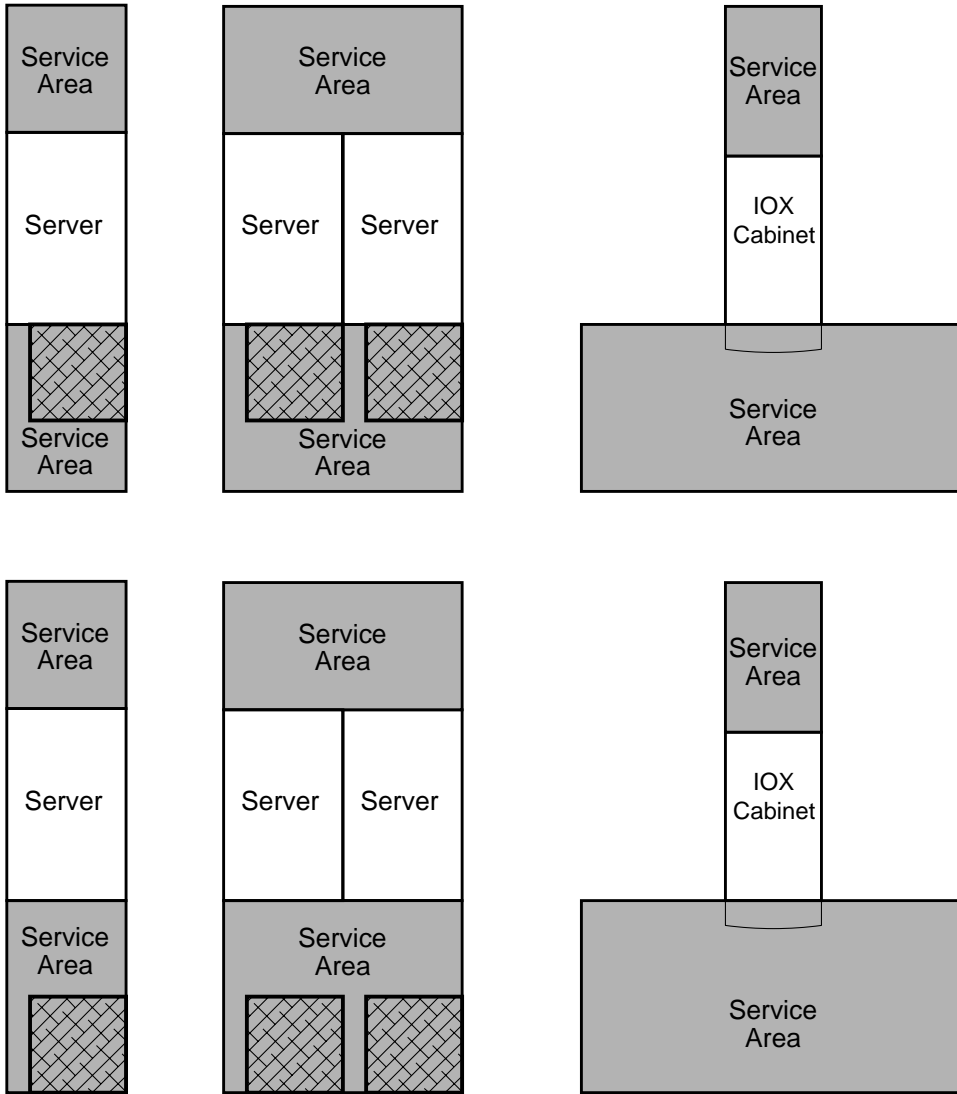

60SP017A
7/16/00

Templates
Computer Room Layout Plan

Scale: 1/4 inch = 1 foot

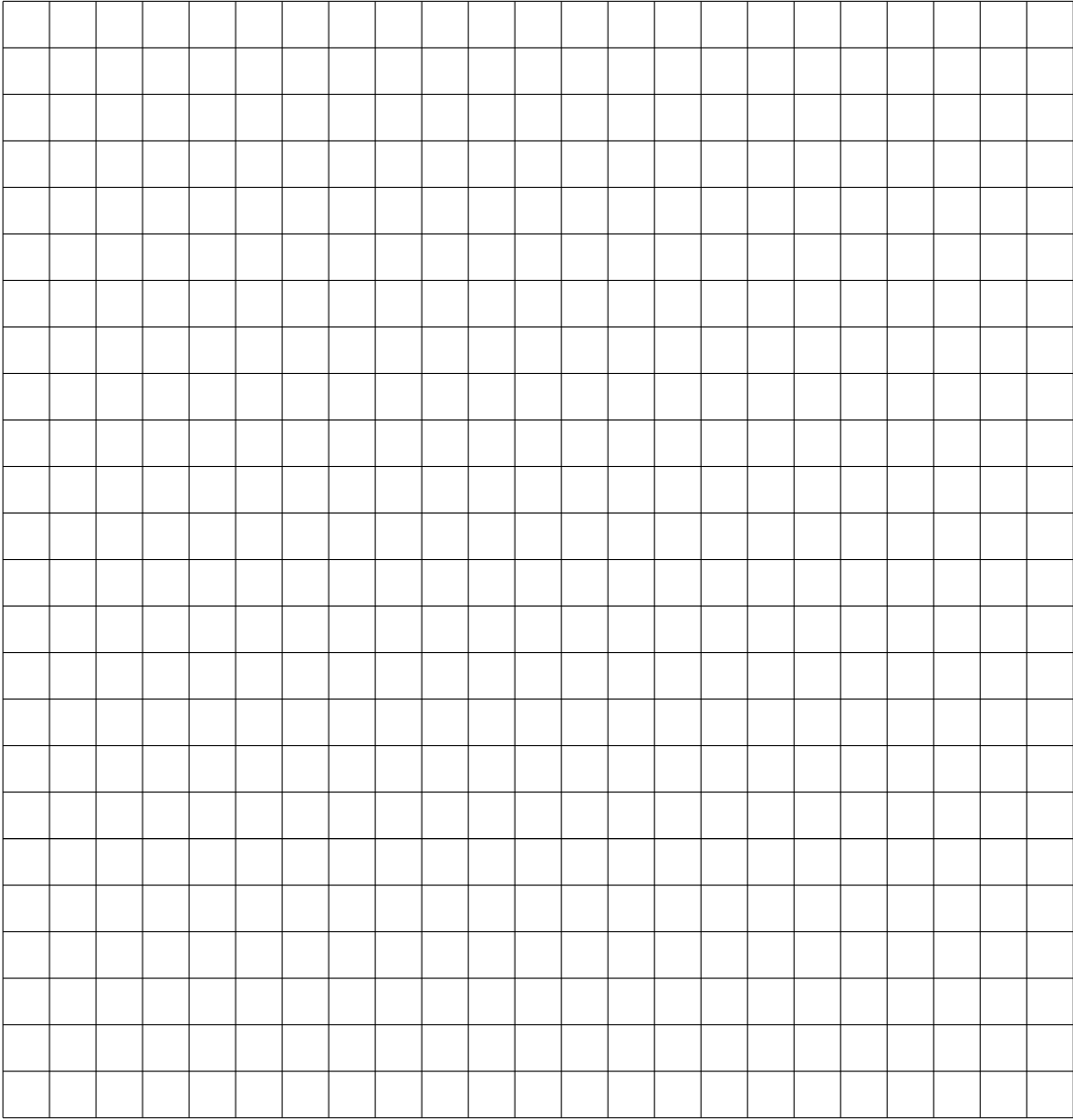

60SP016A
12/20/99

Scale: 1/4 inch = 1 foot

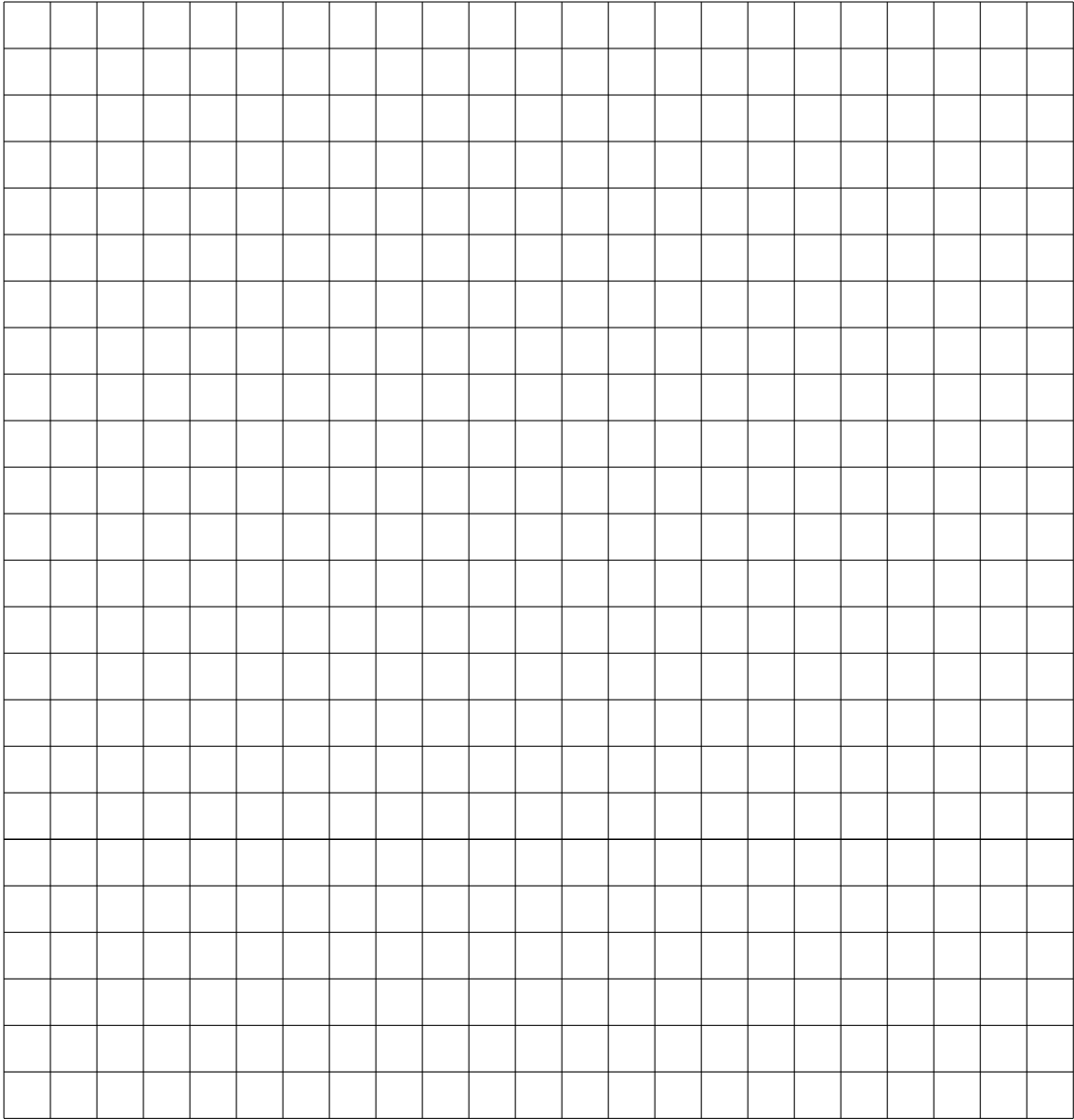

V25U067
10/2/98

Templates
Computer Room Layout Plan

Scale: 1/4 inch = 1 foot

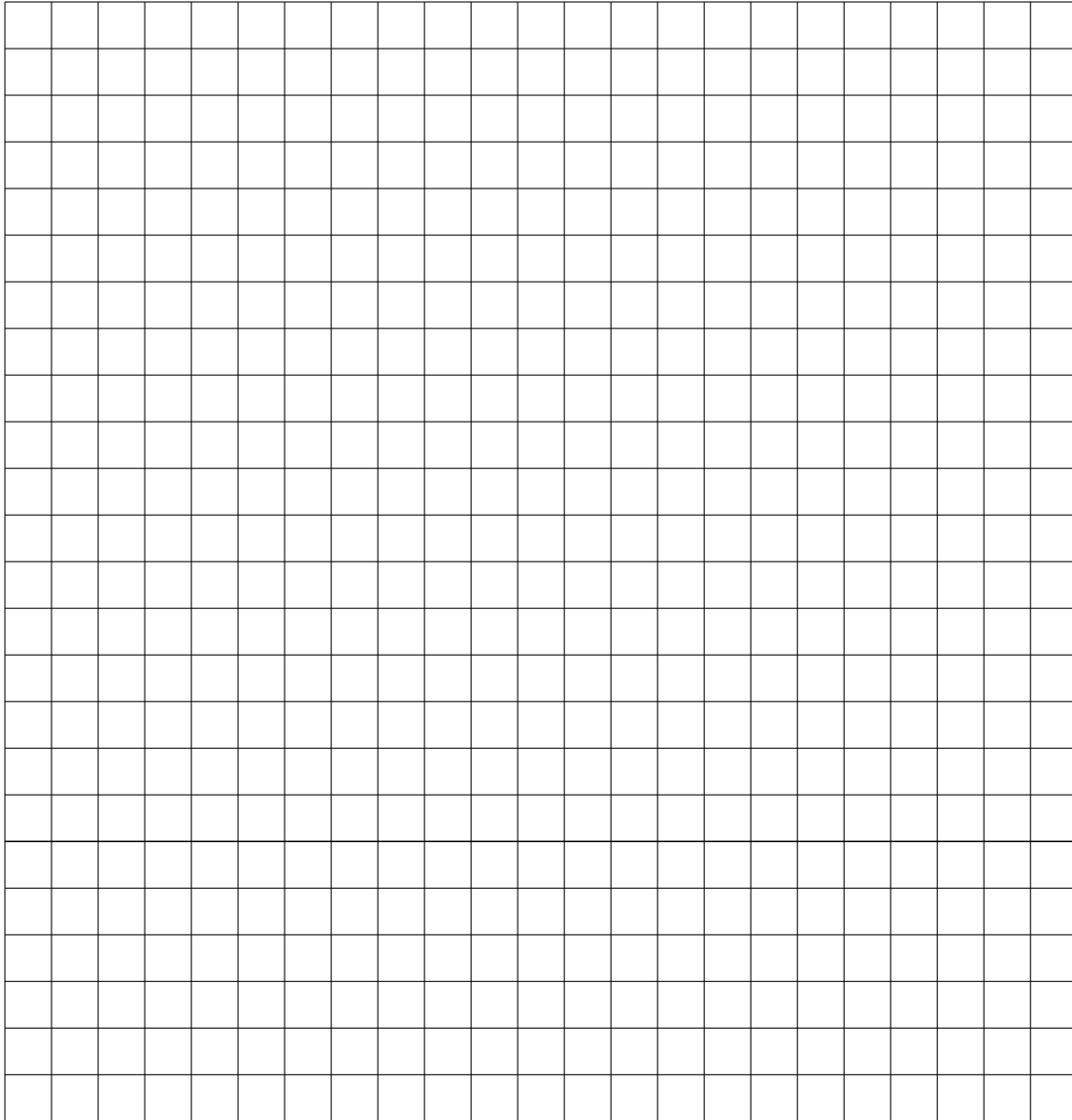

V25U067
10/2/98

Scale: 1/4 inch = 1 foot

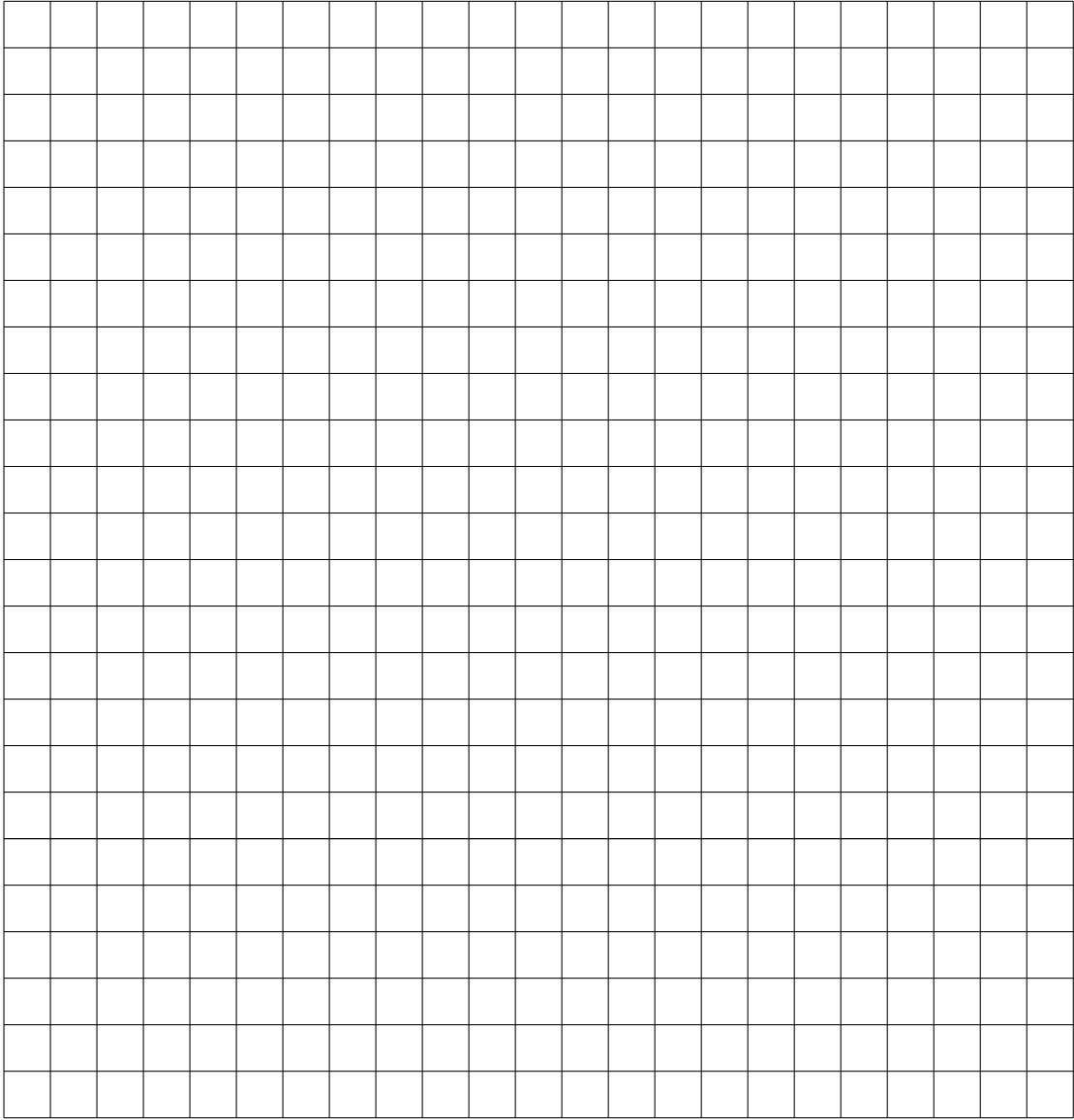

60SP016A
12/20/99

Templates
Computer Room Layout Plan

Scale: 1/4 inch = 1 foot

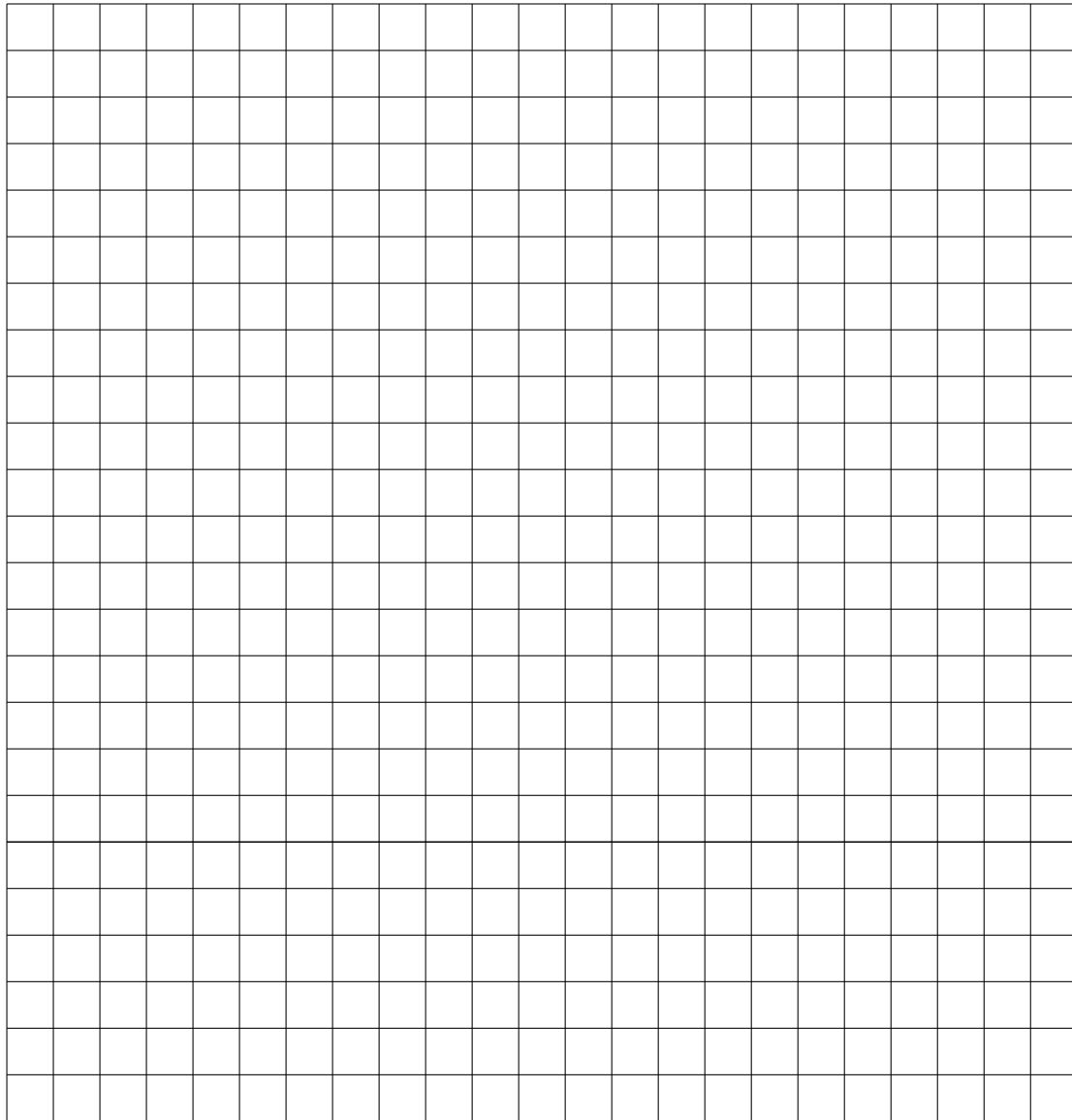

V25U067
10/2/98

B Configuration Guidelines

Configuration Guidelines

To achieve the best performance and high availability consider the following factors as shown in order of importance:

1. Memory Population
2. Cell Population
3. Partition Size
4. I/O Chassis Allocation

Memory Population

Each cell has two memory busses that must be evenly populated to achieve full bandwidth and reduce latency. Configurations of 4 Gbytes, 8 Gbytes, 12 Gbytes, 16 Gbytes, and 32 Gbytes per cell accomplish this.

Memory must be symmetric within each partition for interleaving to be even across all the cells, otherwise performance problems can result. Consider the following example:

Example B-1 Incorrect Memory Distribution Across Partitions

If a two cell partition has 2 Gbytes of memory on one cell and 16 Gbytes on another, 4 Gbytes will be interleaved (two from each cell) and 14 Gbytes will be assigned to one cell only. This will result in inconsistent bandwidth and latency problems.

Cell Population

A group of four cells (a *quad*) resides on one Crossbar Chip (XBC) and has the lowest latency. *Quads* are slots 0-3, 4-7, 8-11 and 12-15.

Keep partitions with a size less than or equal to four on the same *quad*.

Memory traffic from one *quad* to another is routed in pairs. The following pairs share the same path: 0 and 1, 2 and 3, 4 and 5, and 6 and 7.

The hp Integrity Superdome SD32 or hp 9000 Superdome SD32 can have dual links between *quads* if U-turns are installed on the backplane. To use both links a six-cell partition uses slots 0-3, 5, and 7 as would 4 and 6.

Partitions that share links share common points of failure.

XBC-XBC links can saturate and kill performance. An eight-cell partition on an SD6400 should be spread across cabinets. Cab 0, slots 0-3, 5, 7 and Cab 1, slots 4 and 6.

Partition Size

For best performance, partitions should be either single cell or greater powers of 2: 2, 4, 8, and 16 cells.

Memory interleaving is performed by taking either four or six physical address bits and using them to index into a cell mapping table entry consisting of 16 or 64 sub-entries. For a single cell partition, each sub-entry is loaded with only one cell. A two-cell partition alternates between the two cells. There is one 64 sub-entry cell map entry and a 48-16 sub-entry cell entry.

Partitions that are not powers of two will undergo *revisiting*. Consecutive accesses will go through all the cell boards and come back through revisiting as many cells as necessary until all memory is utilized and the 64-entry table is filled.

Table 1, SD64 Partition Configurations, shows configurations that yield the best performance. However, memory may be left over. This memory is interleaved in the 16-entry tables and does not always yield the best performance. Depending on the memory configuration and the partition size the memory system performance will always increase, although not always linearly.

Use the following guidelines when building partitions:

- Build the largest partition first.
- Keep partitions with four cells or less on the same quad. (Slots 0-3, 4-7, 8-11, and 12-15)
- Keep the amount of memory on each cell in a partition as equal as possible.
- Fill empty cabinets before adding to a partially populated cabinet.
- For best performance, partitions should be either single cell or greater powers of 2: 2, 4, 8, and 16 cells.
- Always check a new partition for bottlenecks with the formula $Q_x * Q_y / Q_t / I$. See XBC-XBC Link Load Equation for more information.

The partitions in the following table provide good but not always optimum link loading while allowing for growth.

Table B-1 SD64 Partition Configurations

#Cells per partition	Cabinet 0 - Cell Slots								Cabinet 1 - Cell Slots								#Cells per partition
	0	1	2	3	4	5	6	7	8	9	10	11	12	13	14	15	
1	A	I	E	M	C	K	G	O	B	J	F	N	D	L	H	P	16
2	A	E	A	E	C	G	C	G	B	F	B	F	D	H	D	H	8
3	A	A	A		C	C	C		B	B	B		D	D	D		4
4	A	A	A	A	C	C	C	C	B	B	B	B	D	D	D	D	4
5	A	A	A	A				A	B	B	B	B				B	2
6	A	A	A	A		A		A	B	B	B	B		B		B	2
7	A	A	A	A		A	B	A	B	B	B	B	A	B		B	2
8	A	A	A	A	B	A	B	A	B	B	B	B	A	B	A	B	2
9	A	A	A	A	A	A		A					A		A		1
10	A	A	A	A	A	A	A	A					A		A		1
11	A	A	A	A	A	A	A	A					A	A	A		1
12	A	A	A	A	A	A	A	A					A	A	A	A	1
13	A	A	A	A	A	A	A	A				A	A	A	A	A	1
14	A	A	A	A	A	A	A	A		A		A	A	A	A	A	1
15	A	A	A	A	A	A	A	A		A	A	A	A	A	A	A	1
16	A	A	A	A	A	A	A	A	A	A	A	A	A	A	A	A	1

Table B-1 SD64 Partition Configurations (Continued)

#Cells per partition	Cabinet 0 - Cell Slots								Cabinet 1 - Cell Slots								#Cells per partition
																	48

Table 2 and Figure B-1 show the SD64 partition configurations.

Table B-2 SD64 Partition Configurations

#Cells per partition	Cabinet 0 - Cell Slots								#Cells per partition
1	0	1	2	3	4	5	5	7	8
2	A	E	C	G	B	F	D	H	4
3	A	C	A	C	B	D	B	D	2
4	A	A	A		C	C	C	C	2
5	A	A	A	A	B	B	B	B	1
6	A	A	A	A		A		A	1
7	A	A	A	A		A	A	A	1
8	A	A	A	A	A	A	A	A	1

Figure B-1 SD64

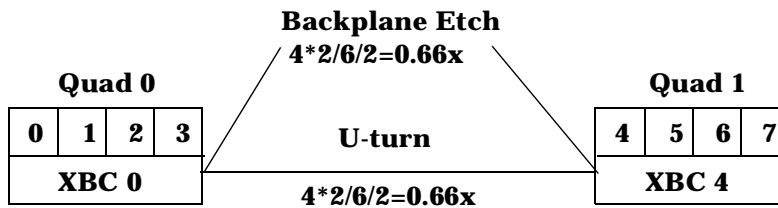

XBC-XBC Link Load Equation

A simple calculation can be made to evaluate whether or not a particular configuration will have bottlenecks.

1. The number of cells on one quad, Q_x , that talk to another quad Q_y
2. The total number of cells is Q_t
3. The number of links between the two quads is L . (Always 1)
4. Link load is $Q_x*Q_y/Q_t/L$. (Link load = $4*4/8/2 = 1$).

Strive always for a link load of 1.0 or less.

The lower the link load, the better off the system. If link loads begin to approach 2, bottlenecks may occur.

For a dual cabinet system, there are six equations covering each link:

1. Quad 0 talking to Quad 1 $L1 = Q0*Q1/Qt/1$
2. Quad 0 talking to Quad 2 $L2 = Q0*Q2/Qt/1$
3. Quad 0 talking to Quad 3 $L3 = Q0*Q3/Qt/1$
4. Quad 1 talking to Quad 2 $L4 = Q1*Q2/Qt/1$
5. Quad 1 talking to Quad 3 $L5 = Q1*Q3/Qt/1$
6. Quad 2 talking to Quad 3 $L6 = Q2*Q3/Qt/1$

I/O Chassis Allocation

For best high availability, I/O devices are connected to different I/O Bays to reduce single points of failure.

Rules dictate that the roots are selected first, then all other I/O are added.

I/O can connect anywhere, but tools will guide you to the best selection.

System Planner

The System Planner is a tool available under AIM. Click on File>Enable>SuperDome>Calculator and Planner.

Using the System Planner you can create a system with partitions ordered with the following information:

- Number of cell boards, memory modules, and active CPUs
- Number of cell boards to reserve for future expansion