

# HP Integrity rx2660 Server User Service Guide

HP Part Number: AB419-9002C  
Published: November 2007



© Copyright 2007 Hewlett-Packard Development Company, L.P

**Legal Notices**

The information contained herein is subject to change without notice. The only warranties for HP products and services are set forth in the express warranty statements accompanying such products and services. Nothing herein should be construed as constituting an additional warranty. HP shall not be liable for technical or editorial errors or omissions contained herein.

Printed in U.S.A.

Intel, Pentium, Intel Inside, Itanium, and the Intel Inside logo are trademarks or registered trademarks of Intel Corporation or its subsidiaries in the United States and other countries.

Linux is a U.S. registered trademark of Linus Torvalds.

Microsoft and Windows are U.S. registered trademarks of Microsoft Corporation.

---

# Table of Contents

About This Document.....	17
Intended Audience.....	17
Publishing History.....	17
Document Organization.....	17
Typographic Conventions.....	18
Related Documents.....	18
HP-UX Release Name and Release Identifier.....	19
Warranty Information.....	19
Related Information.....	19
HP Encourages Your Comments.....	19
<b>1 Overview.....</b>	<b>20</b>
Server Subsystems.....	20
Server Block Diagram.....	20
I/O Subsystem.....	21
PCIe MPS Optimization.....	22
Processor.....	23
Memory.....	23
Cooling.....	24
Data Center Server Cooling.....	24
Office Friendly Server Cooling.....	24
Power.....	25
Data Center Server Power.....	25
Office Friendly Server Power.....	25
Mass Storage.....	26
Firmware.....	26
User Interface.....	26
Event IDs for Errors and Events.....	27
Controls, Ports, and LEDs.....	27
Front Panel Controls, Ports, and LEDs.....	27
System Insight Display.....	29
Storage and Media Devices.....	30
SAS Disk Drive LEDs.....	30
DVD Drive.....	31
Rear Panel Controls, Ports, and LEDs.....	31
iLO 2 MP.....	32
iLO 2 MP Reset Button.....	33
iLO 2 MP Ports.....	33
iLO 2 MP LAN LEDs.....	33
iLO 2 MP Status LEDs.....	33
System LAN.....	34
Power Supply.....	34
Rear Panel UID LED and Button.....	35
PCI-X/PCIe Card Slots.....	35
<b>2 Server Specifications.....</b>	<b>36</b>
System Configuration.....	36
Dimensions and Weight.....	37
Grounding.....	37
Electrical Specifications.....	37
System Power Specifications.....	37
Power Consumption and Cooling.....	38

Physical and Environmental Specifications.....	38
<b>3 Installing the Server.....</b>	<b>42</b>
Safety Information.....	42
Installation Sequence and Checklist.....	43
Unpacking and Inspecting the Server.....	43
Verifying Site Preparation.....	43
Inspecting the Shipping Containers for Damage.....	44
Unpacking the Server.....	44
Checking the Inventory.....	44
Returning Damaged Equipment.....	44
Unloading the Server With a Lifter.....	44
Installing Additional Components.....	45
Introduction.....	45
Installing a SAS Hard Drive.....	45
Removing a SAS Hard Drive Filler.....	45
Installing a SAS Hard Drive.....	46
Installing a Hot-Swappable Power Supply.....	47
Power Supply Loading Guidelines.....	47
Installing a Power Supply.....	48
Removing the Top Cover.....	48
Removing the Airflow Guide.....	49
Installing System Memory.....	51
Memory Installation Conventions.....	51
Supported DIMM Sizes.....	51
Memory Pairs.....	51
Memory Loading Rules and Guidelines.....	52
Installing Memory.....	52
Installing a Processor.....	52
Processor Load Order.....	53
Required Tools.....	53
Replacing the Airflow Guide.....	57
Installing Additional PCIe/PCI-X Cards.....	58
Removing the I/O Backplane from the Server.....	58
Installing a PCIe/PCI-X Card.....	60
Replacing the I/O Backplane Card Cage.....	61
Installing the SAS Smart Array and PCIe Expansion Boards.....	61
Installing the PCIe Expansion Board.....	61
Installing the SAS Smart Array P400 Controller and RAID Battery.....	62
Replacing the Top Cover.....	63
Installing the Server into a Rack or Pedestal.....	64
Installing the Server into a Rack.....	64
HP Rack.....	64
Non-HP Rack.....	64
Installing the Server into a Pedestal.....	64
Connecting the Cables.....	65
ac Input Power.....	65
Power States.....	65
Applying Standby Power to the Server.....	66
Connecting to the LAN.....	66
Connecting and Setting Up the Console.....	67
Setting Up the Console.....	67
Setup Checklist.....	68
Setup Flowchart.....	69
Preparation.....	70

Determining the Physical iLO 2 MP Access Method.....	70
Determining the iLO 2 MP LAN Configuration Method.....	70
Configuring the iLO 2 MP LAN Using DHCP and DNS.....	71
Configuring the iLO 2 MP LAN Using ARP Ping.....	72
Configuring the iLO 2 MP LAN Using the RS-232 Serial Port.....	73
Logging In to the iLO 2 MP.....	74
Additional Setup.....	75
Modifying User Accounts and Default Password.....	75
Setting Up Security.....	75
Security Access Settings.....	76
Accessing the Host Console.....	76
Accessing the Host Console With the TUI - CO Command.....	76
Interacting with the iLO 2 MP Using the Web GUI.....	76
Accessing the Graphic Console Using VGA .....	77
Powering On and Powering Off the Server.....	78
Power States.....	78
Powering On the Server.....	78
Powering On the Server Using the iLO 2 MP.....	79
Powering On the Server Manually.....	79
Powering Off the Server.....	79
Powering Off the Server Using the iLO 2 MP.....	79
Powering Off the Server Manually.....	79
Verifying Installed Components In the Server.....	80
Installation Troubleshooting.....	83
Troubleshooting Methodology.....	83
Troubleshooting Using the Server Power Button.....	84
Server Does Not Power On.....	84
EFI Menu is Not Available.....	85
Operating System Does Not Boot.....	85
Operating System Boots with Problems.....	85
Intermittent Server Problems.....	85
DVD Problems.....	85
Hard Drive Problems.....	86
Console Problems.....	86
Downloading and Installing the Latest Version of the Firmware.....	86
Downloading the Latest Version of the Firmware.....	86
Installing the Latest Version of the Firmware on the Server.....	86
<b>4 Booting and Shutting Down the Operating System.....</b>	<b>87</b>
Operating Systems Supported on HP Integrity Servers.....	87
Configuring System Boot Options.....	87
Booting and Shutting Down HP-UX.....	88
Adding HP-UX to the Boot Options List.....	89
Standard HP-UX Booting.....	89
Booting HP-UX (EFI Boot Manager).....	89
Booting HP-UX (EFI Shell).....	90
Booting HP-UX in Single-User Mode.....	91
Booting HP-UX in LVM Maintenance Mode.....	92
Shutting Down HP-UX.....	93
Booting and Shutting Down HP OpenVMS.....	93
Adding OpenVMS to the Boot Options List.....	93
Booting OpenVMS.....	94
Booting OpenVMS (EFI Boot Manager).....	95
Booting HP OpenVMS (EFI Shell).....	95
Shutting Down OpenVMS.....	96

Booting and Shutting Down Microsoft Windows.....	97
Adding Microsoft Windows to the Boot Options List.....	97
Booting the Microsoft Windows Operating System.....	99
Shutting Down Microsoft Windows.....	100
Windows Shutdown from the Command Line.....	100
Booting and Shutting Down Linux.....	101
Adding Linux to the Boot Options List.....	101
Booting the Red Hat Enterprise Linux Operating System.....	102
Booting Red Hat Enterprise Linux from the EFI Shell.....	103
Booting the SuSE Linux Enterprise Server Operating System.....	103
Booting SuSE Linux Enterprise Server from the EFI Shell.....	103
Shutting Down Linux.....	104
<b>5 Troubleshooting.....</b>	<b>105</b>
Methodology.....	105
General Troubleshooting Methodology.....	105
Recommended Troubleshooting Methodology .....	106
Basic and Advanced Troubleshooting Tables.....	107
Troubleshooting Tools.....	112
LEDs .....	112
Front Panel.....	112
External Health LED.....	113
Internal Health LED.....	113
System Health LED.....	114
Locator Switch/LED (Unit Identifier or UID).....	115
System Insight Display LEDs.....	115
Field Replaceable Unit Health LEDs.....	116
Diagnostics.....	116
Online Diagnostics/Exercisers.....	116
Online Support Tool Availability.....	116
Online Support Tools List.....	117
Linux Online Support Tools.....	117
Offline Support Tools List.....	117
General Diagnostic Tools.....	118
Fault Management Overview.....	118
HP-UX Fault Management.....	118
WBEM Indication Providers and EMS Hardware Monitors.....	119
EMS High Availability Monitors.....	119
Errors and Reading Error Logs.....	119
Event Log Definitions.....	119
Using Event Logs.....	119
iLO 2 MP Event Logs.....	120
System Event Log (SEL) Review.....	120
Supported Configurations.....	122
System Block Diagram.....	122
System Build-Up Troubleshooting Procedure.....	123
CPU/Memory/SBA.....	124
Troubleshooting rx2660 CPU.....	125
IPF Processor Load Order.....	125
Processor Module Behaviors.....	125
Customer Messaging Policy.....	125
Troubleshooting rx2660 Memory.....	127
Memory DIMM Load Order.....	127
Memory Subsystem Behaviors.....	127
Customer Messaging Policy.....	128

Troubleshooting rx2660 SBA.....	128
Power Subsystem .....	129
Power Subsystem Behavior.....	129
Power LED/Switch.....	129
Cooling Subsystem.....	130
Cooling Subsystem Behavior.....	130
I/O Backplane (LBAs/Ropes/PDH/PCI-X/PCIe Slots).....	131
I/O Subsystem Behaviors.....	131
Customer Messaging Policy.....	131
Management Subsystem.....	133
iLO 2 MP LAN LED on the Rear Panel.....	133
iLO 2 MP Status LEDs.....	133
Manageability Reset Button on System Board Bulkhead.....	134
Manageability Status LED.....	134
I/O Subsystem (SAS/DVD/HDD).....	134
Verifying SAS Disk Drive Operation.....	134
System LAN LEDs.....	135
System LAN LEDs.....	135
Booting .....	135
Firmware.....	136
Identifying and Troubleshooting Firmware Problems.....	137
Updates.....	137
Server Interface (System Console).....	137
Troubleshooting Tips.....	137
Environment .....	138
Reporting Your Problems to HP.....	138
Online Support.....	138
Phone Support.....	138
Information to Collect Before you Contact Support.....	138
<b>6 Removing and Replacing Server Components.....</b>	<b>140</b>
Service Tools Required.....	140
Safety Information.....	140
Server Component Classification.....	141
Hot-Swappable Components.....	141
Hot-Pluggable Components.....	141
Cold-Swappable Components.....	142
Accessing a Rack Mounted Server.....	142
Extending the Server from the Rack.....	142
Inserting the Server into the Rack.....	143
Accessing a Pedestal Mounted Server.....	143
Removing and Replacing the Top Cover.....	143
Removing the Top Cover.....	143
Replacing the Top Cover.....	144
Removing and Replacing the Airflow Guide.....	145
Removing the Airflow Guide.....	145
Replacing the Airflow Guide.....	147
Removing and Replacing a Hot-Swappable Server Fan.....	148
Data Center rx2660 Server.....	148
Office Friendly Server.....	149
Removing a Server Fan.....	150
Replacing a Server Fan .....	152
Removing and Replacing a Hot-Swappable Power Supply.....	152
Power Supply Loading Guidelines.....	153
Removing a Power Supply.....	153

Replacing a Power Supply.....	154
Removing and Replacing a Hard Drive Filler.....	154
Removing a Hard Drive Filler.....	154
Replacing a Hard Drive Filler.....	155
Removing and Replacing a Hot-Pluggable SAS Hard Drive.....	155
Removing a SAS Hard Drive.....	155
Replacing a SAS Hard Drive.....	156
Removing and Replacing the DVD Drive.....	157
Removing the DVD Drive.....	157
Replacing the DVD Drive.....	157
Removing and Replacing the Front Bezel.....	157
Removing the Front Bezel.....	158
Replacing the Front Bezel.....	159
Removing and Replacing the System Insight Display.....	159
Removing the System Insight Display.....	159
Replacing the System Insight Display.....	160
Removing and Replacing the Fan Carrier Assembly.....	161
Removing the Fan Carrier Assembly.....	161
Replacing the Fan Carrier Assembly.....	163
Removing and Replacing the I/O Fan Carrier Assembly.....	164
Removing the I/O Fan Carrier Assembly.....	164
Replacing the I/O Fan Carrier Assembly.....	166
Removing and Replacing the I/O Backplane Assembly.....	166
Removing the I/O Backplane Assembly.....	166
Replacing the I/O Backplane Assembly.....	168
Removing and Replacing a PCI-X/PCIe Card.....	169
Removing a PCI-X/PCIe Card.....	169
Installing a PCI-X/PCIe Card.....	169
Removing and Replacing the Fan / Display Board.....	170
Removing the Fan / Display Board.....	171
Replacing the Fan / Display Board.....	172
Removing and Replacing System Memory.....	173
Removing System Memory.....	173
Memory Installation Conventions.....	174
Supported DIMM Sizes.....	174
Memory Load Order.....	174
Memory Loading Rules and Guidelines.....	174
Installing Memory.....	174
Removing and Replacing a Processor.....	175
Processor Load Order.....	176
Required Tools.....	176
Removing a Processor .....	176
Installing a Processor.....	180
Removing and Replacing the Power Supply Housing.....	182
Removing the Power Supply Housing.....	182
Replacing the Power Supply Housing.....	183
Removing and Replacing the Power Supply Riser Board.....	184
Removing the Power Supply Riser Board.....	184
Replacing the Power Supply Riser Board.....	184
Removing and Replacing the System and iLO 2 MP Battery.....	185
Removing the System or iLO 2 MP Battery.....	185
Replacing the System or iLO 2 MP Battery.....	186
Removing and Replacing the Trusted Platform Module.....	186
Removing the TPM.....	187
Replacing the TPM.....	187



Removing and Replacing the Smart Array P400 Controller and PCIe Expansion Board.....	188
Removing the Optional Smart Array P400 Controller and Battery.....	188
Removing the PCIe Expansion Board.....	190
Replacing the Smart Array P400 Controller Board.....	191
Replacing the PCIe Expansion Board.....	192
Removing and Replacing the SAS Backplane Board.....	193
Removing the SAS Backplane Board.....	194
Replacing the SAS Backplane.....	195
Removing and Replacing the System Board.....	195
Removing the System Board.....	196
Replacing the System Board.....	198
<b>A Customer Replaceable Units Information.....</b>	<b>200</b>
Parts Only Warranty Service.....	200
Customer Self Repair.....	200
Customer Replaceable Units List.....	201
<b>B Upgrades.....</b>	<b>204</b>
Upgrading the I/O Backplane.....	204
I/O Backplane Upgrade Overview.....	204
Required Service Tools.....	204
Safety Information.....	204
Upgrading the I/O Backplane.....	205
Performing a Server Backup.....	205
Powering Off the Server.....	205
Accessing the Server.....	205
Removing the I/O Backplane Assembly From the Server.....	206
Removing the PCI-X I/O Backplane Board from the I/O Backplane Assembly.....	207
Installing the PCI-X/PCIe I/O Backplane Board Into the I/O Backplane Assembly.....	208
Replacing the I/O Backplane Assembly Into the Server.....	209
Replacing the Top Cover.....	209
Installing the Server Into the Rack.....	209
Installing the Server Into a Pedestal.....	209
Powering On the Server.....	209
Upgrade Verification.....	209
Viewing Warnings.....	209
Verifying I/O cards.....	209
Booting the Operating System.....	210
Processor Upgrades.....	210
Upgrading Verses Adding On.....	211
Firmware.....	211
Operating Systems.....	211
<b>C Utilities.....</b>	<b>212</b>
Extensible Firmware Interface Boot Manager.....	212
EFI Commands.....	213
EFI/POSSE Commands.....	215
help.....	215
Syntax.....	215
Parameters.....	215
Operation.....	215
baud.....	218
Syntax.....	218
Parameters.....	218
Operation.....	218
boottest.....	219

Syntax.....	219
Parameters.....	219
cpuconfig.....	220
Syntax.....	220
Parameters.....	220
Operation.....	220
ioconfig.....	221
Syntax.....	221
Parameters.....	221
Operation.....	221
conconfig.....	222
Syntax.....	222
Parameters.....	222
Notes.....	222
default.....	223
Syntax.....	223
Parameters.....	223
Operation.....	224
errdump.....	224
Syntax.....	224
Parameters.....	224
Operation.....	224
info.....	224
Syntax.....	224
Parameters.....	224
lanaddress.....	229
Syntax:.....	229
Parameters.....	229
monarch.....	229
Syntax.....	230
Parameters.....	230
Operation.....	230
pdt.....	230
Syntax.....	230
Parameters.....	230
Operation.....	230
sysmode.....	231
Syntax.....	231
Parameters.....	231
Operation.....	231
Option ROM Configuration for Arrays Utility.....	232
Creating a Logical Drive Using ORCA.....	232
Specifying SCSI Parameters.....	233
Using the SCSI Setup Utility.....	233
Using the Boot Option Maintenance Menu.....	238
Paths.....	238
Boot From File.....	238
Add a Boot Option.....	239
Edit Boot Entry.....	240
Delete Boot Option(s).....	240
Change Boot Order.....	240
Manage BootNext Setting.....	240
Set AutoBoot TimeOut.....	241
Select Console Configuration.....	241
Select Active Standard Error Devices.....	242

Using the System Configuration Menu.....	242
Security/Password Menu.....	243
Resetting Passwords.....	243
Advanced System Information.....	243
Set System Time.....	243
Set System Date.....	243
Set User Interface.....	243
Set System Wake-On LAN.....	243
Set System Defaults.....	243
Integrated Lights Out 2 Management Processor.....	243
<b>Index.....</b>	<b>245</b>

---

# List of Figures

1-1	Server Block Diagram.....	21
1-2	I/O Subsystem Block Diagram.....	22
1-3	Memory Block Diagram.....	24
1-4	Power Subsystem Block Diagram.....	25
1-5	Front Panel Controls, Ports, and LEDs.....	27
1-6	Server Status LEDs.....	28
1-7	System Insight Display LEDs.....	29
1-8	Hot-Pluggable SAS Drive LEDs.....	30
1-9	DVD LED.....	31
1-10	Rear Panel Control, Port, and LED Locations.....	32
1-11	iLO 2 MP Controls, Ports, and LEDs.....	32
3-1	Removing a Hard Drive Filler.....	46
3-2	Installing a SAS Hard Drive.....	47
3-3	Power Supply Location.....	48
3-4	Installing a Power Supply.....	48
3-5	Removing the Top Cover.....	49
3-6	Removing the Airflow Guide.....	50
3-7	Fan Carrier Handle.....	50
3-8	Memory Location and Slot IDs.....	51
3-9	Processor Cage Handle.....	54
3-10	Processor Cage Open.....	54
3-11	ZIF Socket, Alignment Holes and Posts, and Slot Locations.....	55
3-12	ZIF Socket.....	56
3-13	Processor Power Connectors.....	57
3-14	Replacing the Airflow Guide.....	58
3-15	I/O Backplane Assembly Screw Locations.....	59
3-16	I/O Backplane Assemblies.....	60
3-17	SAS Smart Array P400 Controller and PCIe Expansion Board Slots.....	62
3-18	Board Lock.....	62
3-19	Installing the RAID battery.....	63
3-20	Replacing the Top Cover.....	64
3-21	Rear Panel Control, Port, and LED Locations.....	66
3-22	iLO 2 MP Setup Flowchart.....	69
3-23	Web Login Page.....	77
3-24	Status Summary Page.....	77
5-1	System Insight Display LEDs.....	115
6-1	Extending the Server from the Rack.....	143
6-2	Removing the Top Cover.....	144
6-3	Replacing the Top Cover.....	145
6-4	Airflow Guide Location.....	146
6-5	Fan Carrier Handle.....	147
6-6	Replacing the Airflow Guide.....	148
6-7	Data Center Server Cooling Zones.....	149
6-8	Office Friendly Server Cooling Zones.....	150
6-9	Removing and Replacing a Data Center Server Fan.....	151
6-10	Removing and Replacing an Office Friendly Server Fan.....	152
6-11	Removing and Replacing a Power Supply.....	154
6-12	Removing and Replacing a Hard Drive Filler.....	155
6-13	Removing a Hot-Pluggable Hard Drive.....	156
6-14	Replacing a SAS Hard Drive.....	156
6-15	Removing the DVD Drive.....	157
6-16	Removing the Front Bezel.....	158

6-17	Bezel Screw Location.....	158
6-18	Removing the System Insight Display from the Front Bezel.....	160
6-19	Removing and Replacing the Fan Carrier Assembly.....	162
6-20	Data Center Fan Carrier Assembly Removed.....	163
6-21	Office Friendly Server Fan Carrier Assembly Removed.....	163
6-22	Removing and Replacing the Data Center Server I/O Fan Carrier Assembly.....	165
6-23	Removing and Replacing the Office Friendly Server I/O Fan Carrier Assembly.....	165
6-24	Removing the I/O Backplane Assembly.....	167
6-25	I/O Backplane Assembly Removed.....	168
6-26	Removing and Replacing the Fan / Display Board.....	172
6-27	Memory Location and Slot IDs.....	173
6-28	Opening and Closing the Processor Cage.....	177
6-29	Processor Cage Open.....	178
6-30	Processor Power Connectors and Cables.....	178
6-31	Processor ZIF Socket, and Alignment Holes and Posts.....	179
6-32	ZIF Socket.....	180
6-33	Removing the Power Supply Housing .....	182
6-34	Power Supply Housing Removed From the Server.....	183
6-35	Power Supply Riser Board.....	184
6-36	System and iLO 2 MP Battery Locations.....	186
6-37	TPM Location on System Board.....	187
6-38	Smart Array P400 Controller Location on System Board.....	189
6-39	Removing the Battery from the Airflow Guide.....	190
6-40	Removing the PCIe Expansion Board.....	191
6-41	Installing the Battery on the Airflow Guide.....	192
6-42	Installing the PCIe Expansion Board.....	193
6-43	Removing and Replacing the SAS Backplane.....	195
6-44	Removing and Replacing the System Board.....	197
B-1	I/O Backplane Assembly Screw Locations.....	206
B-2	Removing the I/O Backplane Assembly.....	207
B-3	I/O Backplane Removed.....	208
B-4	Installing the PCI-X/PCIe I/O Backplane.....	208
C-1	EFI Boot Sequence.....	212
C-2	ORCA Main Menu.....	232
C-3	Console Configuration.....	242

---

# List of Tables

1	Publishing History Details.....	17
2	HP-UX 11i Releases.....	19
1-1	Front Panel Controls.....	28
1-2	Front Control Panel LEDs.....	28
1-3	SAS Disk Drive LEDs.....	30
1-4	iLO 2 MP Ports.....	33
1-5	iLO 2 MP LAN Link Speed LEDs.....	33
1-6	iLO 2 MP LAN Link Status LEDs.....	33
1-7	iLO 2 MP Status LEDs.....	34
1-8	System LAN Link Status LEDs.....	34
1-9	System LAN Link Speed LEDs.....	34
1-10	Power Supply LED.....	34
1-11	Rear Panel UID LED.....	35
2-1	Hardware Specifications.....	36
2-2	Rack- or Pedestal-Mounted Server Dimensions.....	37
2-3	System Power Specifications.....	38
2-4	Additional Component Power Consumption.....	38
2-5	Environmental Specifications (system processing unit with hard disk).....	39
2-6	Physical and Environmental Specifications for the Data Center Server.....	40
2-7	Physical and Environmental Specifications of the Office Friendly Server.....	41
3-1	Installation Sequence Checklist.....	43
3-2	Memory Load Order.....	52
3-3	rx2660 Processor Load Order.....	53
3-4	Power States.....	65
3-5	Setup Checklist.....	68
3-6	Console Connection Matrix.....	70
3-7	LAN Configuration Methods.....	71
3-8	ARP Ping Commands.....	72
3-9	Power States.....	78
3-10	Server Power Button Functions When Server is On and at EFI.....	84
3-11	Server Power Button Functions When Server is On and OS is Running.....	84
3-12	Server Power Button Functions When Server is Off.....	84
5-1	Troubleshooting Entry Points .....	107
5-2	Front Panel LED States.....	108
5-3	Basic Low End Troubleshooting.....	108
5-4	Advanced Low End Troubleshooting.....	111
5-5	External Health LED States.....	113
5-6	VFP External Health Description.....	113
5-7	Internal Health LED States.....	114
5-8	VFP Internal Health Description.....	114
5-9	System Health LED States.....	114
5-10	VFP System Health Description.....	115
5-11	System Insight Display LED States.....	115
5-12	Online Support Tools List.....	117
5-13	Offline Support Tools List.....	117
5-14	General Diagnostic Tools List.....	118
5-15	Processor Events That Light System Insight Display LEDs.....	125
5-16	Processor Events That May Light System Insight Display LEDs.....	126
5-17	Memory Subsystem Events That Light System Insight Display LEDs.....	128
5-18	Memory Subsystem Events That May Light System Insight Display LEDs.....	128
5-19	Power LED States.....	130
5-20	Cooling Subsystem Events That Light System Insight Display LEDs.....	130

5-21	I/O Subsystem Events That Light System Insight Display LEDs.....	131
5-22	I/O Card Events That May Light System Insight Display LEDs.....	131
5-23	PCI-X Rope to ACPI Paths.....	133
5-24	PCIe/PCI-X Rope to ACPI Paths.....	133
5-25	iLO 2 MP LAN LED States.....	133
5-26	iLO 2 MP Status LEDs.....	134
5-27	Manageability Status LED.....	134
5-28	Gb LAN 1 Connector LEDs.....	135
5-29	Gb LAN 2 Connector LEDs.....	135
5-30	Normal Boot Process LED States.....	135
5-31	rx2660 Environmental Specifications.....	138
6-1	Memory Load Order.....	174
6-2	Supported Processor Configurations.....	175
6-3	Processor Load Order.....	176
A-1	Customer Self Repair Information.....	201
A-2	HP Integrity rx2660 CRU List.....	201
B-1	Slot Speed Comparison.....	204
B-2	Processor Upgrades.....	210
C-1	EFI Commands.....	213
C-2	Communications Parameters.....	219
C-3	PCI Slots and Device Path.....	238
C-4	Disk Drives and Device Path.....	238

---

# List of Examples

C-1	help command.....	216
C-2	help bch command.....	216
C-3	help configuration command.....	216
C-4	help cpuconfig command.....	217
C-5	<b>help ioconfig</b> command.....	218
C-6	boottest command.....	220
C-7	boottest early_cpu off command.....	220
C-8	cpuconfig command.....	221
C-9	<b>ioconfig</b> command.....	222
C-10	conconfig command.....	223
C-11	conconfig 2 primary command.....	223
C-12	conconfig 3 off command.....	223
C-13	conconfig 3 on command.....	223
C-14	info all command.....	225
C-15	info cpu command.....	227
C-16	info mem command.....	228
C-17	info io command.....	228
C-18	info boot command.....	229
C-19	lanaddress command.....	229
C-20	monarch command.....	230
C-21	pdt command.....	231
C-22	pdt clear command.....	231
C-23	sysmode command.....	232



# About This Document

This document provides information, installation procedures, and server specifications for the HP Integrity rx2660 server, Regulatory Model Number: RSVLA-0503. It also provides parts information and describes how to remove and replace server components, troubleshoot, and diagnose server problems.

The document printing date and part number indicate the document's current edition. The printing date changes when a new edition is printed. Minor changes may be made at reprint without changing the printing date. The document part number changes when extensive changes are made.

Document updates may be issued between editions to correct errors or document product changes. To ensure that you receive the updated or new editions, you should subscribe to the appropriate product support service. See your HP sales representative for details.

The latest version of this document can be found online at: <http://docs.hp.com>.

## Intended Audience

This document is intended to provide technical product and support information for authorized service providers, customer system administrators, and HP support personnel.

## Publishing History

Table 1 lists the publishing history details for this document.

**Table 1 Publishing History Details**

Document Manufacturing Part Number	Operating Systems Supported	Supported Product Versions	Publication Date
AB419-9002A	<ul style="list-style-type: none"><li>• HP-UX,</li><li>• Microsoft® Windows®</li><li>• Linux®</li><li>• OpenVMS</li></ul>	rx2660	December 2006
AB419-9002B	<ul style="list-style-type: none"><li>• HP-UX,</li><li>• Microsoft Windows</li><li>• Linux</li><li>• OpenVMS</li></ul>	rx2660 Data Center and rx2660 Office Friendly	May 2007
AB419-9002C	<ul style="list-style-type: none"><li>• HP-UX,</li><li>• Microsoft Windows</li><li>• Linux</li><li>• OpenVMS</li></ul>	rx2660 Data Center and rx2660 Office Friendly	November 2007

## Document Organization

The *HP Integrity rx2660 Server User Service Guide* is divided into several chapters, and each contains information about servicing the HP Integrity rx2660 server. The appendixes area of the book contains supplemental information.

- Chapter 1** Provides information on the major server subsystems, dimensions and weights, specifications, and safety.
- Chapter 2** Provides server details such as system configuration, physical specifications, and requirements.
- Chapter 3** Provides procedures to install the server.
- Chapter 4** Provides procedures to boot and shut down the operating system.

Chapter 5	Provides diagnostics and basic troubleshooting methodology.
Chapter 6	Provides instructions and procedures on how to remove and replace server components.
Appendix A	Provides a list of replaceable parts.
Appendix B	Provides upgrade procedures.
Appendix C	Provides information on EFI utilities.

## Typographic Conventions

This document uses the following conventions:



**WARNING!** A warning lists requirements that you must meet to avoid personal injury.



**CAUTION:** A caution provides information required to avoid losing data or to avoid losing system functionality.



**NOTE:** A note highlights useful information such as restrictions, recommendations, or important details about HP product features.

<i>Book Title</i>	The title of a book. On the web and on the Instant Information CD, it may be a hot link to the book itself.
<b>KeyCap</b>	The name of a keyboard key. <b>Return</b> and <b>Enter</b> both refer to the same key.
<i>Emphasis</i>	Text that is emphasized.
<b>Bold</b>	Text that is strongly emphasized, or the defined use of an important word or phrase.
ComputerOut	Text displayed by the computer.
<b>UserInput</b>	Commands and other text that you type.
Command	A command name or qualified command phrase.
<i>Variable</i>	The name of a variable that you may replace in a command or function or information in a display that represents several possible values.
[ ]	The contents are optional in formats and command descriptions. If the contents are a list separated by  , you must choose one of the items.
{ }	The contents are required in formats and command descriptions. If the contents are a list separated by  , you must choose one of the items.
...	The preceding element may be repeated an arbitrary number of times.
	Separates items in a list of choices.

## Related Documents

The *HP Server Documentation CD* has been provided with the server. The CD provides the following complete set of documentation:

- *HP Integrity rx2660 Server Installation Guide*
- *HP Integrity rx2660 Server Site Preparation Guide*
- *HP Integrity rx2660 Server Safety and Regulatory Information*
- *HP Integrity rx2660 Server Console Quickstart*
- *HP Integrity rx2660 Server Pedestal Installation Guide*

The latest versions of these documents, and any updates to these documents, are posted under the *Enterprise Servers, Workstations and Systems Hardware* collection under *HP Integrity rx2660* at: <http://docs.hp.com>.

# HP-UX Release Name and Release Identifier

Each HP-UX 11i release has an associated release name and release identifier. The `uname (1)` command with the `-r` option returns the release identifier. This table shows the releases available for HP-UX 11i.

**Table 2 HP-UX 11i Releases**

Release Identifier	Release Name	Supported Processor Architecture
B.11.31	HP-UX 11i v3	Intel® Itanium®

## Warranty Information

The latest versions of the *BCS Global Limited Warranty and Technical Support* documentation is posted on the HP website in the *Enterprise Servers, Workstations, and System Hardware* collection under each server to which it applies, at: <http://www.docs.hp.com>.

## Related Information

You can find other information on HP server hardware management, Microsoft Windows, and diagnostic support tools in the following publications.

**Web Site for HP Technical Documentation:** <http://www.docs.hp.com/en/hw.html>

**Server Hardware Information:** <http://docs.hp.com/hpux/hw/>

**Windows Operating System Information** You can find information about administration of the Microsoft Windows operating system at the following websites, among others:

- [http://docs.hp.com/windows\\_nt/](http://docs.hp.com/windows_nt/)
- <http://www.microsoft.com/technet/>

**Diagnostics and Event Monitoring: Hardware Support Tools** Complete information about HP hardware support tools, including online and offline diagnostics and event monitoring tools, is available on the HP website at: <http://docs.hp.com/hpux/diag/>.

This site has manuals, tutorials, FAQs, and other reference material.

**Web Site for HP Technical Support:** <http://us-support2.external.hp.com/>

**Books about HP-UX Published by Prentice Hall** The <http://www.hp.com/hpbooks/> website lists the HP books that Prentice Hall currently publishes, such as:

- *HP-UX 11i System Administration Handbook*  
[http://www.hp.com/hpbooks/prentice/ptr\\_0130600814.html](http://www.hp.com/hpbooks/prentice/ptr_0130600814.html)
- *HP-UX Virtual Partitions*  
[http://www.hp.com/hpbooks/prentice/ptr\\_0130352128.html](http://www.hp.com/hpbooks/prentice/ptr_0130352128.html)

HP books are available worldwide through bookstores, online booksellers, and office, and computer stores.

## HP Encourages Your Comments

HP encourages your comments concerning this document. We are truly committed to providing documentation that meets your needs.

Send comments to: [netinfo\\_feedback@cup.hp.com](mailto:netinfo_feedback@cup.hp.com).

Include document title, manufacturing part number, and any comment, error found, or suggestion for improvement you have concerning this document. Also, please include what we did right so we can incorporate it into other documents.

---

# 1 Overview

The HP Integrity rx2660 server is a versatile, high-rack-density platform that provides the following features:

Form factor	2U, rack- or pedestal-mounted chassis
Internal peripherals	Serial-attached SCSI (SAS) hard drives, and a DVD or DVD+RW drive
High-availability components	1+1 hot-swappable power supplies and SAS drives
Processors	Up to two single- or dual-core Intel Itanium
Memory	Up to 32 GB

---



**NOTE:** There are two versions of the server included in this guide. The Data Center version, and the Office Friendly version. These two versions are very similar. However, the Data Center server provides N+1 hot-swappable fans. The Office Friendly version provides different fans, a minimum of two power supplies, and can **only** be configured as a pedestal-mounted server.

When reading fan, cooling, or power information, there is Data Center server information, as well as Office Friendly server information throughout this document.

---

This chapter addresses the following topics:

- “Server Subsystems” (page 20)
  - “Server Block Diagram” (page 20)
  - “I/O Subsystem” (page 21)
  - “Processor” (page 23)
  - “Memory” (page 23)
  - “Cooling” (page 24)
  - “Power” (page 25)
  - “System Insight Display” (page 29)
  - “Mass Storage” (page 26)
  - “Firmware” (page 26)
- “Controls, Ports, and LEDs” (page 27)

## Server Subsystems

This section explains the subsystems included with the HP Integrity rx2660 server.

## Server Block Diagram

Figure 1-1 is a block diagram of the main server subsystems. It illustrates the main components of each subsystem and how the subsystems are connected to one another.

**Figure 1-1 Server Block Diagram**

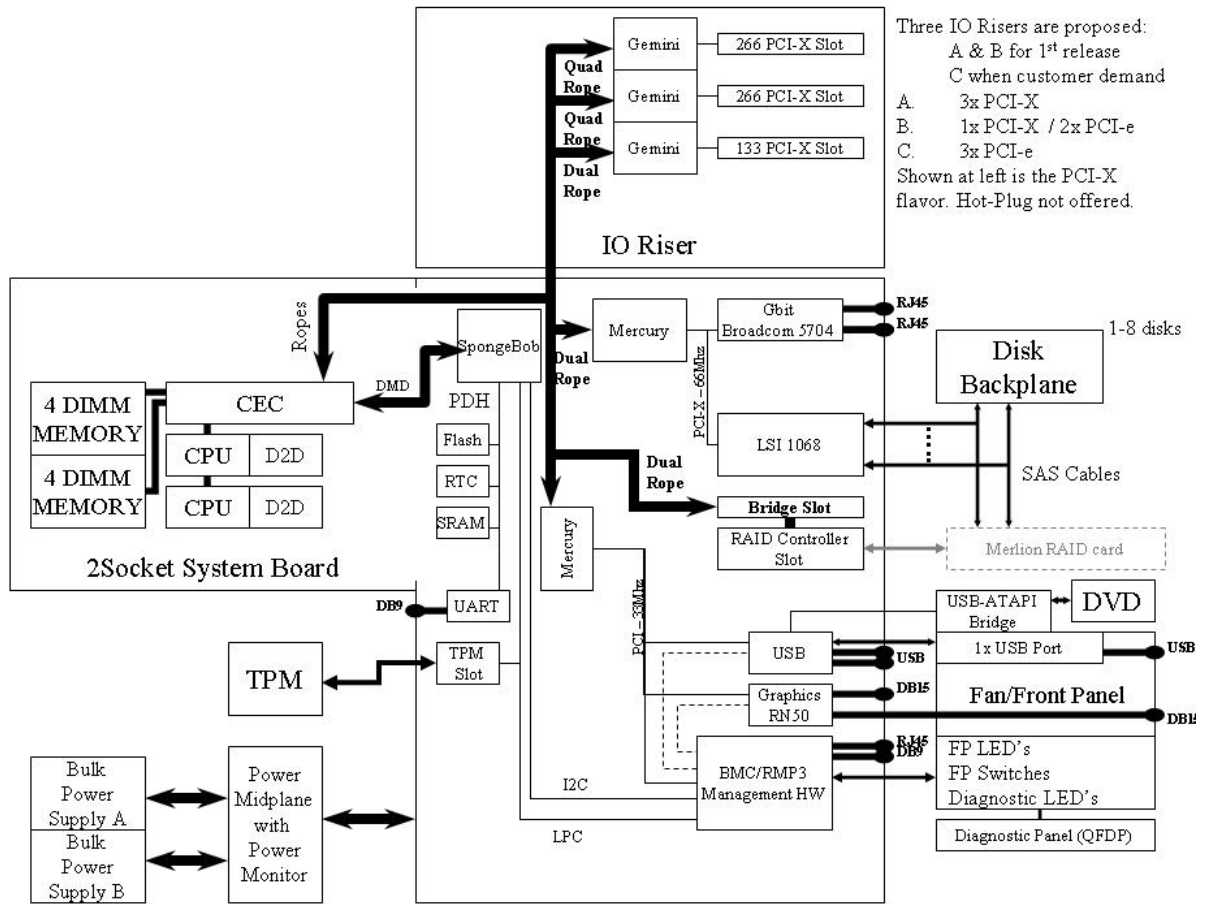

## I/O Subsystem

Figure 1-2 shows a block diagram of the I/O subsystem.

**Figure 1-2 I/O Subsystem Block Diagram**

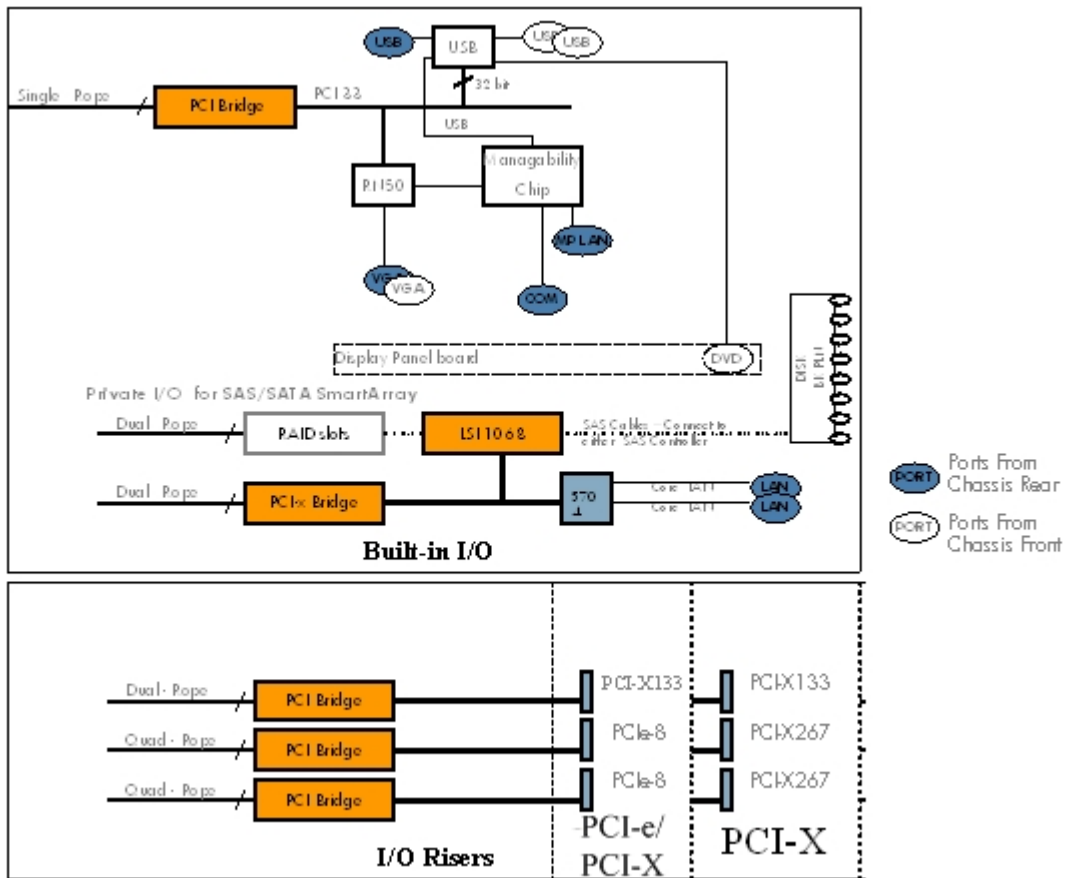

The server is configured with either a PCI-X or a PCIe/PCI-X I/O backplane.

The PCI-X backplane includes three full-length public PCI-X slots. The PCIe/PCI-X backplane has two full-length public PCIe slots and one full-length public PCI-X slot. Wake-on-LAN is not supported on any of the PCIe/PCI-X slots. The server does not support PCI hot plug.

The server provides a pair of internal slots that support optional RAID cards for the SAS hard drives:

- The first slot supports a PCI expansion card that contains an express I/O adapter (EIOA) chip for translating ropes to the PCIe bus.
- The second slot supports the RAID host bus adapter (HBA). The RAID HBA supports an optional 256-MB mezzanine card and external battery. The battery is mounted on top of the plastic CPU airflow guide, and is connected to the RAID HBA by a power cable. When the RAID HBA is installed, the SAS cables are connected to the HBA instead of the LSI 1068 controller on the system board.

### PCIe MPS Optimization

For PCIe-based systems, each PCIe device has a configurable MPS (maximum payload size) parameter. Larger MPS values can enable the optimization to gain higher performance. MPS Optimization is supported on PCIe systems running HP-UX, Open VMS, and Linux. System firmware level greater than 01.05 performs an optimization during boot time to set the MPS value to the largest size supported by both a PCIe root port and the devices below it.

The default server state is optimization disabled. When disabled, system firmware sets MPS to the minimum value on each PCIe device.

The `info io` command displays the current PCIe MPS optimization setting. See “info” (page 224).

To enable PCIe MPS optimization use the `ioconfig mps_optimize` command. See “[ioconfig](#)” (page 221).

For non-PCIe systems, `ioconfig` and `info io` does not display the MPS optimization policy setting. The **Set PCIe MPS Optimization** boot manager menu also is not displayed. When you run the `ioconfig mps_optimize [on|off]` command from a non-PCIe system, the following output displays:

```
-----
Shell> ioconfig mps_optimize
ioconfig: PCIe MPS optimization is not supported.

Shell> ioconfig mps_optimize on
ioconfig: PCIe MPS optimization is not supported.
Exit status code: Unsupported

Shell>
-----
```

To restore MPS to the default values, use the `default clear` command. See “[default](#)” (page 223).

## Processor

The server processor subsystem supports one or two single- or dual-core Itanium processors. The processor subsystem consists of the following features:

- zx2 chipset, front side bus, memory, and I/O controller (MIOC)
- System clock generation and distribution
- Circuitry for manageability and fault detection

The zx2, MIOC, and the processors are located on the system board. Each processor connects to the board through a zero insertion force (ZIF) socket.

## Memory

The eight server DIMMs attach directly to the system board. The supported DIMMs are industry-standard, 30 mm (1.18 in) high, PC2-4200 DIMMs. Hot-spare and hot-plug functionality is not supported.

The server supports the following DIMM sizes:

- 512 MB
- 1 GB
- 2 GB
- 4 GB

The minimum amount of memory supported is 1 GB (two x 512-MB DIMMs). The maximum amount of memory supported is 32 GB (eight x 4-GB DIMMs).

Figure 1-3 is a block diagram of the server memory that shows data, addresses, and controls that flow directly to and from the processors. The server has eight memory slots.

**Figure 1-3 Memory Block Diagram**

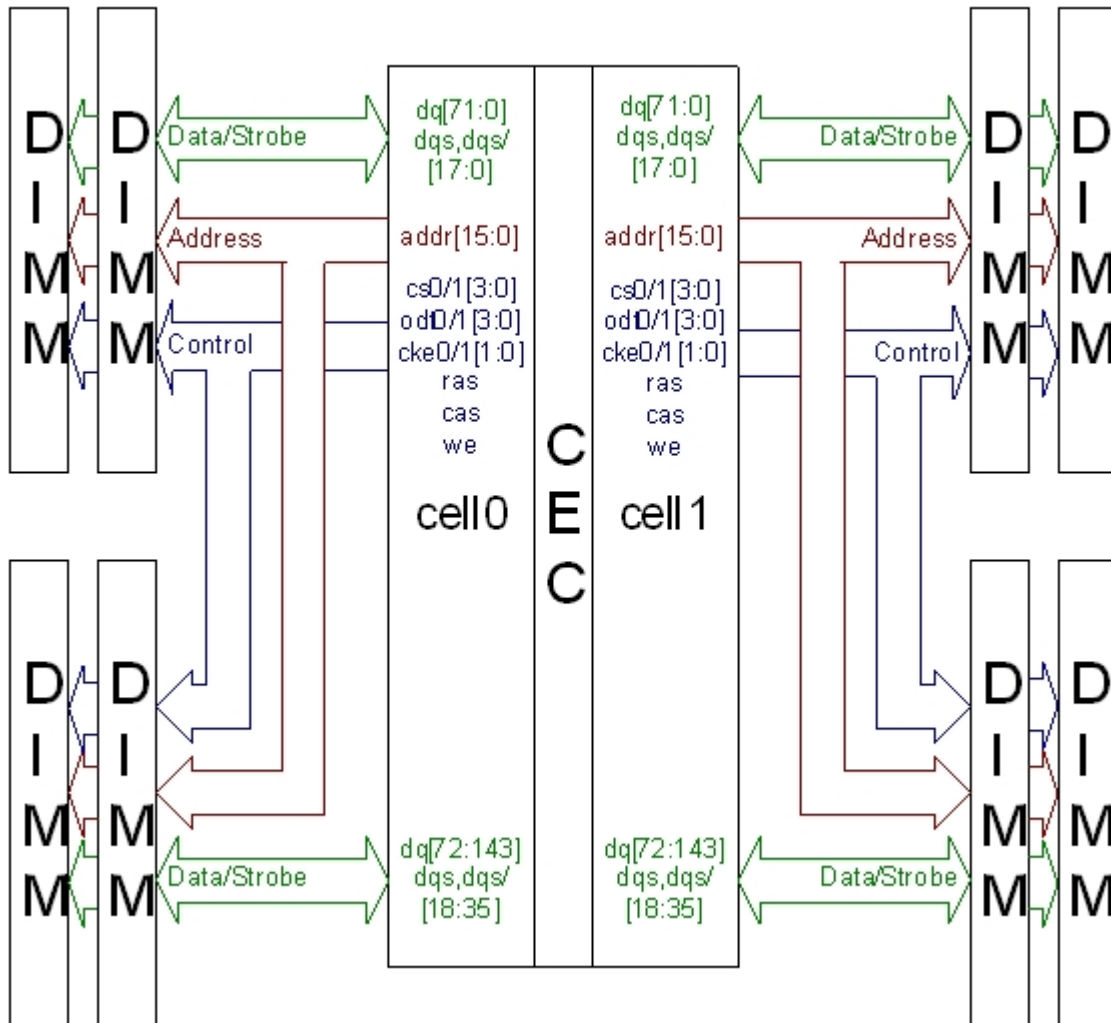

## Cooling

### Data Center Server Cooling

Twelve fans cool the Data Center server. The fans are all redundant, hot-swappable, and interchangeable. Eight fans cool the eight DIMMs and two processors. Four fans cool the hard-disk drives and the PCI riser board. The fans cool three zones in the server. Fans 1 through 4 cool Zone 1, fans 5 through 8 cool Zone 2, and fans 9 through 12 cool Zone 3. Each zone can run with one fan failure. The other fans in the zone increase speed to compensate for the fan failure. The fans are N+1 per zone, meaning that the server has 12 fans, but can operate with 9 fans running (one fan failure per zone). See Figure 6-7 (page 149) for the Data Center fan locations and cooling zones.

The power supplies have built-in fans and are not controlled by the Baseboard Management Controller (BMC).

### Office Friendly Server Cooling

Six fans cool the Office Friendly server. The server fans have two rotors per fan. Four fans cool the eight DIMMs and two processors. Two fans cool the hard-disk drives and the PCI riser board. The fans cool three zones in the server. Fans 1 and 2 cool Zone 1, fans 3 and 4 cool Zone 2, and fans 5 and 6 cool Zone 3. In the Office Friendly configuration, there is N+1 redundancy in Zone 1 and Zone 3 when one fan rotor fails. If a fan rotor fails in Zone 2, the server performs a soft





## Mass Storage

The server mass storage subsystem contains the following major components:

- Small form factor (SFF), 2.5 in. serial-attached SCSI (SAS) hard drives with the following supported capacities:
  - 36 GB
  - 73 GB
  - 146 GB
- SAS cables
- SAS backplane
- SAS HP Smart Array P400 controller card, power cable, and battery (optional)

The server supports up to eight SAS hard drives. Each drive is equipped with LEDs that indicate activity and device status.

The SAS drives connect directly into the SAS backplane. Two cables connect the SAS backplane to the integrated SAS core I/O on the system board. Optionally, these cables connect to the SAS Smart Array P400 controller card installed in a private PCIe slot on the system board.

## Firmware

Firmware consists of many individually linked binary images that are bound together by a single framework at run time. Internally, the firmware employs a software database called a device tree to represent the structure of the hardware platform and to provide a means of associating software elements with hardware functionality.

The firmware incorporates the following main interfaces:

- Processor Abstraction Layer (PAL). PAL provides a seamless firmware abstraction between the processor and system software and platform firmware.
- System Abstraction Layer (SAL). SAL provides a uniform firmware interface and initializes and configures the platform.
- Extensible Firmware Interface (EFI). EFI provides an interface between the operating system and the platform firmware. EFI uses data tables that contain platform-related information, and boot and runtime service calls that are available to the operating system and its loader to provide a standard environment for booting.
- Advanced Configuration and Power Interface (ACPI). ACPI provides a standard environment for configuring and managing server systems. ACPI moves system power configuration and management from the system firmware to the operating system and abstracts the interface between the platform hardware and the operating system software. This allows each to evolve independently of the other.

The rx2660 Data Center server firmware supports the HP-UX 11i version 3, February 2007 release, Linux, Windows, and OpenVMS 8.3 operating systems through the Itanium processor family standards and extensions, and has no operating system-specific functionality included.

The rx2660 Office Friendly server firmware supports the HP-UX 11i version 3, February 2007 release, Linux, Windows, and OpenVMS 8.3 operating systems through the Itanium processor family standards and extensions, and has no operating system-specific functionality included.

All operating systems are presented with the same interface to system firmware, and all features are available to the operating system.

## User Interface

The Itanium processor family firmware employs a user interface defined by an HP standard called Pre-OS System Startup Environment (POSSE). The POSSE shell is based on the EFI standard shell. Several commands were added to the standard EFI Shell to support HP value-added functionality.

## Event IDs for Errors and Events

The system firmware generates event IDs for errors, events, and forward progress to the integrated Lights Out 2 Management Processor (iLO 2 MP) through common shared memory. The iLO 2 MP interprets and stores event IDs. Reviewing these events helps you diagnose and troubleshoot problems with the server.

## Controls, Ports, and LEDs

This chapter provides a basic description of the controls, ports, and LEDs found on the front panel and rear panel of the HP Integrity rx2660. For more information on LED functions and descriptions, see Chapter 5: “Troubleshooting” (page 105).

This chapter addresses the following topics:

- “Front Panel Controls, Ports, and LEDs” (page 27)
- “Rear Panel Controls, Ports, and LEDs” (page 31)

### Front Panel Controls, Ports, and LEDs

The front panel of the server provides the controls, ports, and LEDs commonly used when the server is operational.

Figure 1-5 (page 27) shows the control, port, and LED locations on the server front panel.

**Figure 1-5 Front Panel Controls, Ports, and LEDs**

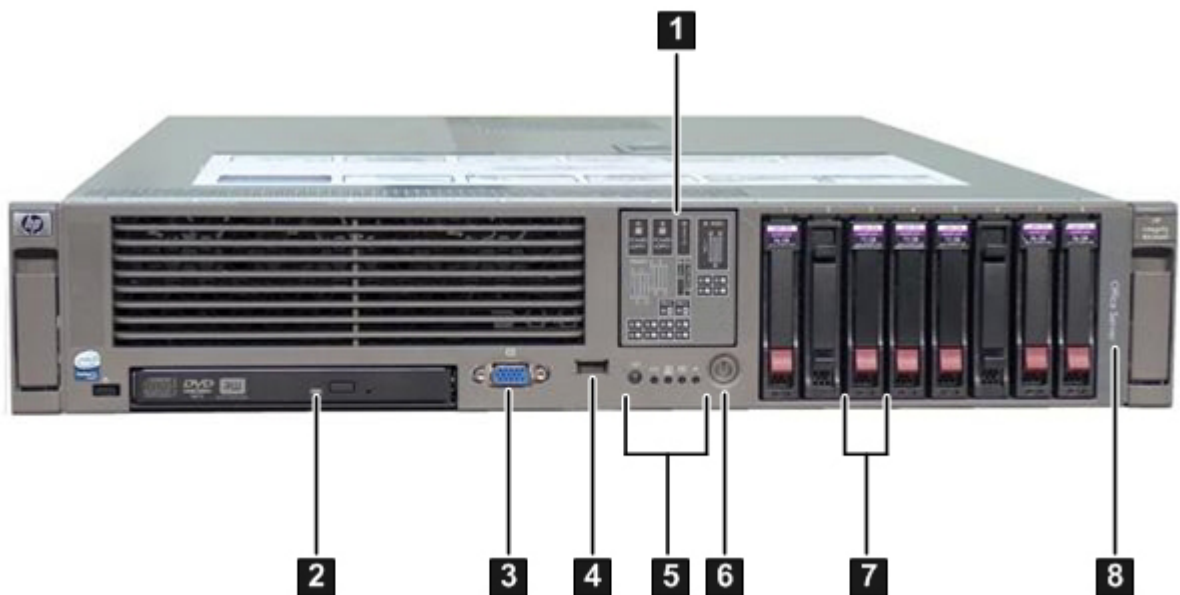

- |                                      |                             |                                       |
|--------------------------------------|-----------------------------|---------------------------------------|
| <b>1</b> System Insight Display LEDs | <b>4</b> USB port           | <b>7</b> SAS disk drive LEDs          |
| <b>2</b> DVD LED                     | <b>5</b> Server status LEDs | <b>8</b> Office Friendly server label |
| <b>3</b> VGA port                    | <b>6</b> Power button       |                                       |



**NOTE:** Figure 1-5 (page 27) shows the Office Friendly server LEDs. The LEDs for the Data Center server are the same. The only difference is the Data Center server does not have the Office Server label on the bezel.

Table 1-1 lists the front panel controls.

**Table 1-1 Front Panel Controls**

Name	Function
Power button	The power button manually powers the server on and off.
UID button	The Unit ID (UID) button helps locate a particular server within a rack of servers. You may remotely activate this function through various system utilities.
Init (ToC) button	The Init (Transfer of Control) button initiates a system reset. This preserves the entire memory image for obtaining a crash dump and OS error information. Use this button to recover a hung system, and to get debugging information. It is less harsh than a power reset.

Figure 1-6 shows the front control panel LEDs.

**Figure 1-6 Server Status LEDs**



- |                            |                                 |
|----------------------------|---------------------------------|
| <b>1</b> UID button/LED    | <b>4</b> Internal health LED    |
| <b>2</b> Init (ToC) button | <b>5</b> External health LED    |
| <b>3</b> System health LED | <b>6</b> Power LED (and button) |

Table 1-2 lists the server status LEDs.

**Table 1-2 Front Control Panel LEDs**

Name	States
UID LED	<ul style="list-style-type: none"> <li>Off: UID button is not activated</li> <li>Blue: UID button is activated</li> </ul> <p>There is an additional UID LED and button located on the rear panel of the server. Both the front and rear UID LEDs illuminate when you activate either of the front or rear UID buttons</p>
Init (ToC) LED (and button)	<p>The Init (ToC) (transfer of control) LED button initiates a system reset. This reset preserves the entire memory image to obtain crash-dump and OS-error information. The LED illuminates when the system reset is in progress.</p>
System health LED	<p>Provides information about the system status.</p> <p>The following are LED states:</p> <ul style="list-style-type: none"> <li>Off: system is off</li> <li>Green: system is operating normally</li> </ul>

**Table 1-2 Front Control Panel LEDs** (*continued*)

Name	States
	<ul style="list-style-type: none"> <li>• Flashing amber: warning</li> <li>• Flashing red: system fault</li> </ul>
Internal health LED	<p>Indicates the status of internal serviceable components. This LED maintains its state when the system is in standby mode (system power turned off, but ac power is still applied to the system). When the internal health LED is illuminated, the LED of the corresponding failed component illuminates on the System Insight Display. See Chapter 5: “Troubleshooting” (page 105) for more details on the internal health LEDs.</p> <p>The following are LED states:</p> <ul style="list-style-type: none"> <li>• Off: system is off</li> <li>• Green: system health is good</li> <li>• Flashing amber: system health is degraded</li> <li>• Flashing red: system health is critical</li> </ul>
External health LED	<p>Indicates the status of external serviceable components. When the external health LED is illuminated, the LED of the corresponding failed component illuminates.</p> <p>The following are LED states:</p> <ul style="list-style-type: none"> <li>• Off: system is off</li> <li>• Green: system health is good</li> <li>• Flashing amber: system health is degraded</li> <li>• Flashing red: system health is critical</li> </ul>
Power LED	<ul style="list-style-type: none"> <li>• Off: no ac power</li> <li>• Green: full power is on</li> <li>• Yellow: standby power is on</li> </ul>

## System Insight Display

The System Insight Display enables you to monitor a single location for the LEDs that provide failing customer replaceable unit (CRU) locating/mapping information for internal system components. These LEDs are solid amber in color only when a failure occurs, and are otherwise unlit (they are not green the rest of the time). The LEDs are visible on the front panel. Diagnostic LEDs are provided for each internal CRU in the system, including all DIMMs, and system fans. Figure 1-7 (page 29) shows the System Insight Display on the front of the server.

**Figure 1-7 System Insight Display LEDs**





**NOTE:** The System Insight Display is the same for the Data Center server and the Office Friendly server. However, the Office Friendly server only uses the bottom row of fan LEDs since there are only six fans for the Office Friendly server.

## Storage and Media Devices

The server contains up to eight hot-pluggable SAS disk drives and one DVD or DVD+RW drive. Storage and media devices have LEDs that indicate activity and device status.

### SAS Disk Drive LEDs

The SAS hard drives have two LEDs per drive, as described below. See [Figure 1-8](#):

**Drive Activity LED** The drive activity LED is solid green during normal operation and flickers when a drive is accessed.

**Drive Status LED** The drive status LED is bi-color and can display amber or blue. Amber indicates a warning, or failure condition. Blue is a locator LED that identifies a particular disk drive. The locator LED is activated through various software utilities, such as online diagnostics and SAS disk drive configuration tools.

Figure 1-8 shows the SAS disk drive LEDs.

**Figure 1-8 Hot-Pluggable SAS Drive LEDs**



**1** Drive activity LED

**2** Drive status LED

Table 1-3 lists the SAS disk drive LEDs and states ([Figure 1-8](#)).

**Table 1-3 SAS Disk Drive LEDs**

Activity LED	Status LED	SAS Disk Drive State
Off	Off	Offline or not configured
Solid green	Off	Normal operation; no activity
Flickering green	Off	Normal operation; disk read or write activity
Off	Flashing amber at 1 Hz	Offline, no activity; predictive failure

**Table 1-3 SAS Disk Drive LEDs** (continued)

Activity LED	Status LED	SAS Disk Drive State
Solid green	Flashing amber at 1 Hz	Online, no activity; predictive failure
Flickering green	Flashing amber at 1 Hz	Disk activity; predictive failure
Off	Solid amber	Offline; no activity; critical fault
Off	Solid blue	Offline; drive selected by locator function
Flashing green at 1 Hz	Off	Drive rebuilding

### DVD Drive

The server has one DVD drive or one DVD-RW drive. This device has one activity LED (Figure 1-9).

**Figure 1-9 DVD LED**

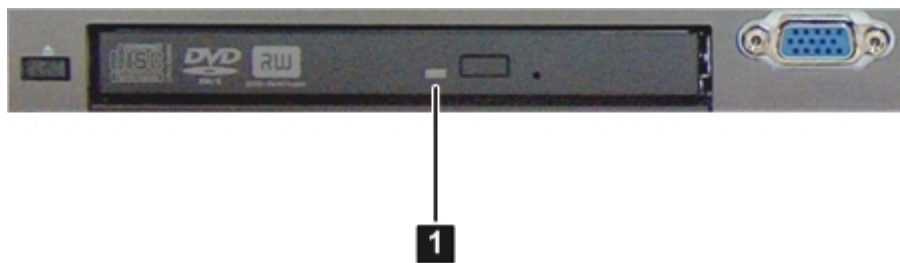

**1** DVD activity LED

### Rear Panel Controls, Ports, and LEDs

The server rear panel includes communication ports, I/O ports, ac power connectors, and the locator LED and button. LEDs located on the rear panel of the server signal the operational status of the following components:

- iLO 2 MP
- System LAN
- Power supply
- PCI-X/PCIe slots

Figure 1-10 (page 32) shows the rear panel controls, port, and LED locations.

**Figure 1-10 Rear Panel Control, Port, and LED Locations**

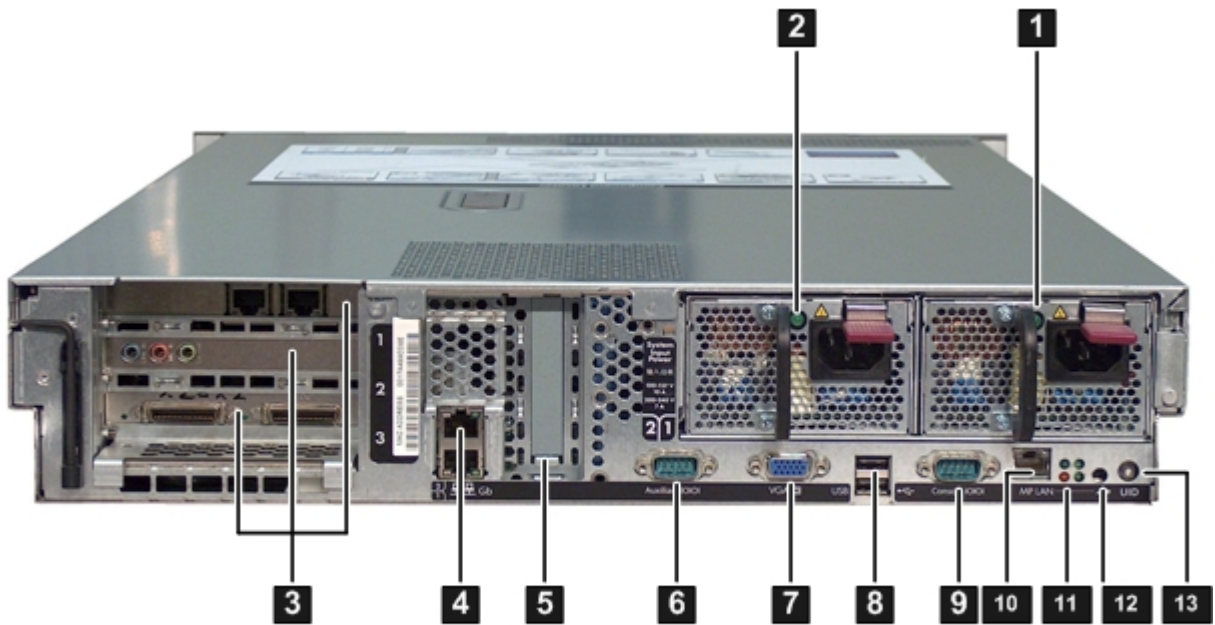

- |   |                                |                                |
|---|--------------------------------|--------------------------------|
| <b>1</b> Power supply 1 and LED           | <b>6</b> Auxiliary serial port | <b>10</b> iLO 2 MP LAN port    |
| <b>2</b> Power supply 2 and LED           | <b>7</b> VGA port              | <b>11</b> iLO 2 MP status LEDs |
| <b>3</b> PCI-X/PCIe slots                 | <b>8</b> USB ports             | <b>12</b> iLO 2 MP reset       |
| <b>4</b> Core LAN ports                   | <b>9</b> Console serial port   | <b>13</b> UID button/LED       |
| <b>5</b> Smart Array P400 controller slot |                                |                                |



**NOTE:** The Office Friendly server is shown in Figure 1-10 (page 32). The Data Center server may only have one power supply installed.

## iLO 2 MP

The server contains an iLO 2 MP on the system board to enable local and remote management of the server. As long as ac power is present, the iLO 2 MP is active, regardless of whether the front panel power switch is off or on.

Figure 1-11 shows the iLO 2 MP controls, ports, and LEDs.

**Figure 1-11 iLO 2 MP Controls, Ports, and LEDs**

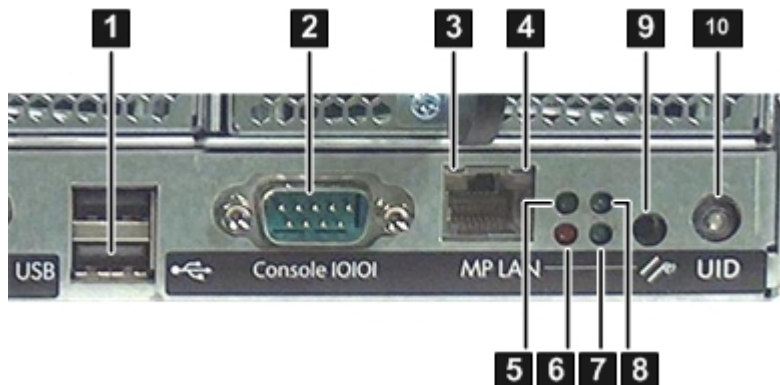



- |                                       |                                     |                                |
|---------------------------------------|-------------------------------------|--------------------------------|
| <b>1</b> USB ports                    | <b>5</b> iLO 2 MP LAN heartbeat LED | <b>8</b> Standby power LED     |
| <b>2</b> Console serial port          | <b>6</b> iLO 2 MP LAN self-test LED | <b>9</b> iLO 2 MP reset button |
| <b>3</b> iLO 2 MP LAN link speed LED  | <b>7</b> BMC heartbeat LED          | <b>10</b> UID button/LED       |
| <b>4</b> iLO 2 MP LAN link status LED |                                     |                                |

### iLO 2 MP Reset Button

The iLO 2 MP reset button enables you to reset the iLO 2 MP, and optionally reset the user-specific values to factory default values. A momentary press causes a soft reset of the iLO 2 MP when the button is released. A greater than four second press causes a soft reset of the iLO 2 MP upon release; it also returns user-specific values to factory default values. The following are reset to factory default values:

- Serial terminal baud rate settings
- User names and passwords

### iLO 2 MP Ports

Table 1-4 lists a description of the iLO 2 MP ports shown in Figure 1-11.

**Table 1-4 iLO 2 MP Ports**

Port	Description
10 Base-T/100 Base-T LAN	LAN port dedicated for remote access to the iLO 2 MP
Auxiliary serial	Local serial port
Console serial (iLO 2 MP)	Local serial port that provides a console connection to the server
USB	Two public USB 2.0 ports used primarily to connect to a keyboard and mouse for console input functions (Windows and Linux operating systems only).
VGA	VGA port used primarily to connect to a monitor that displays console output (Windows and Linux operating systems only).

### iLO 2 MP LAN LEDs

Table 1-5 lists the iLO 2 MP LAN link speed LEDs and states.

**Table 1-5 iLO 2 MP LAN Link Speed LEDs**

Link Speed	LED State
100 Mb	Solid amber
10 Mb	Off

Table 1-6 lists the iLO 2 MP LAN link status LEDs and states.

**Table 1-6 iLO 2 MP LAN Link Status LEDs**

Link Status	LED State
Activity	Blinking green
Link with no activity	Solid green
No link	Off

### iLO 2 MP Status LEDs

Table 1-7 lists the state of the iLO 2 MP status LEDs during normal operation.

**Table 1-7 iLO 2 MP Status LEDs**

iLO 2 MP Status LED	LED State
iLO 2 MP heartbeat	Flashing green
iLO 2 MP self-test	Off: The LED is solid amber when ac power is applied. It remains solid amber for a few seconds until the iLO 2 MP completes its self-test; then the LED turns off.
BMC heartbeat	Flashing green
Standby power	Solid green

## System LAN

The system LAN functionality is integrated into the system board. The following describes the system LAN ports:

- Two RJ-45 style 10 Base-T/100 Base-T/1000 Base-T system LAN ports.

Table 1-8 lists the core LAN link status LEDs and states.

**Table 1-8 System LAN Link Status LEDs**

Link Status	LED State
Activity	Blinking green
Link with no activity	Solid green
No link	Off

Table 1-9 lists the system LAN link speed LEDs and states.

**Table 1-9 System LAN Link Speed LEDs**

Link Status	LED State
1000 Mb	Solid orange
100 Mb	Solid green
10 Mb	Off

## Power Supply

The server is equipped with one or two power supplies, labeled PS1 and PS2. Each power supply has an ac input receptacle and an LED that shows the power state of the server. See [Figure 1-10 \(page 32\)](#) for the LED location.

The server has three power states: standby power, full power, and off. To achieve the standby power state, plug the power cord into the appropriate receptacle at the rear of the server. To achieve full power, plug the power cord into the appropriate receptacle, and either push the power button or enter the iLO 2 MP `PC` command. In the off state, power cords are not connected to a power source. For more information on power states, see “Power States” (page 78).

Table 1-10 lists the power supply LED states.

**Table 1-10 Power Supply LED**

Power Supply Condition	Power Supply LED
No ac power	Off
ac power; standby power on	Blinking green
Full power on; normal operation	Solid green
Power supply failure	Blinking amber

## Rear Panel UID LED and Button

The UID button is used to help locate a particular server in a rack of servers. See [Figure 1-10 \(page 32\)](#) for the UID button location. You may remotely activate this function through various system utilities.

Table 1-11 lists the rear panel UID LED states.

**Table 1-11 Rear Panel UID LED**

Name	States
UID LED	<ul style="list-style-type: none"><li>• Off: UID button is not activated.</li><li>• Blue: UID button is activated.</li></ul> <p>There is an additional UID LED and button on the front control panel of the server. Both the front and rear UID LEDs illuminate when you activate the front or rear UID button.</p>

## PCI-X/PCIe Card Slots

The server has three public PCI-X/PCIe slots on the I/O backplane assembly. The I/O backplane assembly is located on the system board. Depending on what options you purchased, you have one of the following I/O backplane assemblies, with the included riser board:

**PCI-X riser board:** Three full-length PCI-X public slots

**Combo riser board:** Two full-length PCIe public slots, and one full-length PCI-X public slot



**NOTE:** Wake-on-LAN is not enabled on any of the PCI-X/PCIe slots.

PCI-X/PCIe hot-plugging is not supported on the rx2660 server.

There are no LEDs associated with the PCI-X/PCIe cards.

---

## 2 Server Specifications

This chapter provides the specifications for the HP Integrity rx2660 server.

This chapter addresses the following topics:

- “System Configuration” (page 36).
- “Dimensions and Weight” (page 37)
- “Grounding” (page 37).
- “Electrical Specifications” (page 37).
- “Physical and Environmental Specifications” (page 38)

For information on general computer room site preparation, see the *HP Generalized Site Preparation Guide* on the HP website at [www.docs.hp.com](http://www.docs.hp.com).

### System Configuration

Table 2-1 lists the hardware specifications for the HP Integrity rx2660 server.

**Table 2-1 Hardware Specifications**

Component	HP Integrity rx2660
Processors	One or two Itanium single- or dual-core processors: <ul style="list-style-type: none"><li>• 1.6 GHz/6 MB cache single-core processor</li><li>• 1.4 GHz/12 MB cache dual-core processor</li><li>• 1.6 GHz/18 MB cache dual-core processor</li><li>• 1.6 GHz/12 MB cache single-core processor</li><li>• 1.42 GHz/12 MB cache dual-core processor</li><li>• 1.67 GHz/18 MB cache dual-core processor</li></ul>
Memory	Supports up to eight Double Data Rate 2 (DDR2) DIMMs mounted on the system board. Supported DIMM sizes are as follows: <ul style="list-style-type: none"><li>• 512 MB</li><li>• 1 GB</li><li>• 2 GB</li><li>• 4 GB</li></ul> Minimum memory configuration is 1 GB (2 x 512 MB DIMMs). Maximum memory configuration is 32 GB (8 x 4 GB DIMMs).
Disk drives	One to eight hot-pluggable SAS hard drives.
PCI slots	For the PCI-X I/O backplane assembly: <ul style="list-style-type: none"><li>• One PCI-X slot @ 133 MHz</li><li>• Two PCI-X slots @ 266 MHz</li></ul> For the PCIe/PCI-X I/O backplane assembly: <ul style="list-style-type: none"><li>• One PCI-X slot @ 133 MHz</li><li>• Two PCIe slots @ PCIe x8</li></ul>
SAS core I/O	Eight port SAS core I/O card, or eight port SAS core I/O card with RAID expansion card.
LAN core I/O	Two GigE LAN ports.
Management core I/O	Two serial ports, two USB 2.0 ports, one 10 Base-T/100 Base-T LAN port, and one optional VGA port.
Optical device	One DVD-R or DVD+RW.
Power supply	The Data Center server has one 900 watt (@120 VAC) or 1000 watt (@240 VAC) power supply, 1+1 redundancy with second power supply. The Office Friendly configuration includes two power supplies.

## Dimensions and Weight

Table 2-2 lists the dimensions and weight of the HP Integrity rx2660 Data Center server and the rx2660 Office Friendly server for a rack- or pedestal-mounted configuration.

**Table 2-2 Rack- or Pedestal-Mounted Server Dimensions**

Dimensions and Weight	Value
Data Center Server Dimensions	
• Depth	• 67.3 cm (26.5 in)
• Width	• 48.3 cm (19 in)
• Height	• 8.6 cm (3.4 in)
Data Center Server Weight	Minimum configuration – 21 kg (46 lb) Maximum configuration – 28 kg (61 lb)
Rack unit	2U
Office Friendly Server Dimensions	
• Depth	• 69.0 cm (27.18 in)
• Width	• 27.6 cm (10.88 in) w/feet 12.7 cm (5 in) w/o feet
• Height	• 50.8 cm (20 in)
Office Friendly Server Weight	Minimum configuration – 30 kg (66 lb) Maximum configuration – 37 kg (81 lb)

## Grounding

The site building shall provide a safety ground/protective earth for each ac service entrance to all cabinets.

Install a PE (protective earthing) conductor that is identical in size, insulation material, and thickness to the branch-circuit supply conductors. The PE conductor must be green with yellow stripes. The earthing conductor is to be connected from the unit to the building installation earth or, if supplied by a separately derived system, at the supply transformer or motor-generator set grounding point.

## Electrical Specifications

This section provides electrical specifications for the server.

### System Power Specifications

Available power (output) is the maximum dc power that the power supply can supply to the system.

Maximum input power is what the power supply requires from the ac line to deliver that maximum dc output (given worst case efficiency and maximum loading).

Maximum input current is the worst case/highest current given the lowest input voltage and the maximum input power.

**Table 2-3 System Power Specifications**

Parameter	Total Rating		
Input voltage	100 VAC	100-127 VAC	200-240 VAC
Marked input current	10 A	10 A	7 A
Input current (maximum)	10 A	10 A	6.7 A
Input frequency	47 to 63 Hz	47 to 63 Hz	47 to 63 Hz
Maximum ac input power	1000 W	1000 W	1205 W
Power supply maximum output power	800 W	850 W	1000 W
Max current at +12 V	65 A	69 A	82 A
Max current at -12 V	0.3 A	0.3 A	0.3 A
Max current at +3.3 V standby	8 A	8 A	8 A
Max current at +5 V standby	2 A	2 A	2 A

If an overload triggers the power supply overload protection, the system is immediately powered off. To reset the power supply unit, follow these steps:

1. Disconnect the power cord.
2. Determine what caused the overload by contacting an HP support representative.
3. Reconnect the power cord.
4. Reboot the system.



**NOTE:** If an overload occurs twice, there is an undetected short circuit somewhere.

When you use the front panel power button to turn off the server, power consumption falls below the low power consumption, but doesn't reach zero. To reach zero power consumption in "off" mode, either unplug the server or use a power block with a switch.

## Power Consumption and Cooling

The power consumptions listed in Table 2-4 are valid for a standard configuration as shipped (one 1.4 GHz dual-core processor, 1 GB of memory, one 1000 W power supply, one internal hard disk drive, and one internal DVD-RW drive).

All information in this section is based on primary power consumptions with one power supply installed.

**Table 2-4 Additional Component Power Consumption**

Additional Component	Power Consumption	
Processor	130 W	443.6 Btu/h
SAS disk drive (with I/O access)	23 W	78.4 Btu/h
SAS disk (idle)	16 W	54.5 Btu/h
PCIe/PCI-X card	10 to 25 W	34.12 Btu/h to 85.30 Btu/h

## Physical and Environmental Specifications

This section provides the temperature and humidity requirements, noise emission, and air flow specifications for the server.

Operating temperature and humidity ranges may vary depending on the installed mass storage devices. High humidity levels can cause improper disk operation. Low humidity levels can aggravate static electricity problems and cause excessive wear of the disk surface.

Temperature, humidity, and sound power levels are provided in Table 2-5 while minimum, maximum, and typical configurations are in Table 2-6 (page 40) and Table 2-7 (page 41).



**NOTE:** De-rate maximum dry bulb temperature 1 degree/300 meters (1000 feet) above 900 meters 3000 feet).

**Table 2-5 Environmental Specifications (system processing unit with hard disk)**

Parameter		Value	
Operating temperature		+5° C to +35° C (+41° F to +95° F)	
Storage temperature		- 40° C to +60° C (-40° F to +140° F)	
Over-temperature shutdown		+38° C (+100° F)	
Operating humidity		20% to 80% relative (non-condensing)	
Storage humidity		90% relative (non-condensing) at + 65° C	
Acoustic Noise Emission (ISO 9296)		Data Center Server	Office Friendly Server
Sound Power Level	Typical configuration (disk idle) <sup>1</sup>	LwAd = 6.8 B	LwAd = 5.9 B
	Maximum configuration (disk idle) <sup>2</sup>	LwAd = 6.8 B	LwAd = 5.9 B
	Maximum configuration (disk active) <sup>3</sup>	LwAd = 7.0 B	LwAd = 5.9 B
Sound Pressure Level		LpAm = 51.6 dB	LpAm = 41.4 dB
Altitude			
Operating altitude		0 to 3000 m (10,000 ft.) maximum	
Storage altitude		0 to 4572 m (15,000 ft.) maximum	

1 Typical configuration at room temperature (25°C).

2 Single processor, one to two SCSI hard disk drives and less than 8 GB of memory.

3 Dual processor, three SCSI hard disk drives and more than 8 GB of memory.

Table 2-6 (page 40) shows the physical and environmental specifications for the Data Center server.

**Table 2-6 Physical and Environmental Specifications for the Data Center Server**

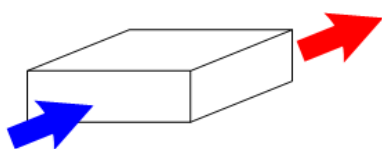
	Condition						Weight			Server Dimensions								
	Typical Heat Release		Nominal Airflow		Maximum Airflow @ 35 degrees C <sup>1</sup>		Server	Rack	Pedestal	Rack	Pedestal							
	100-127 VAC	200-240 VAC																
	Watts	Watts	CFM	m <sup>3</sup> /hr	CFM	m <sup>3</sup> /hr												
Minimum Config.	363 W	363 W	61	104	112	190	21 kg - 28 kg (46 lb - 61 lb)	25 kg - 32 kg (55 lb - 70 lb)	30 kg - 37 kg (66 lb - 81 lb)	D 67.3 cm W 48.3 cm H 8.6 cm (D 26.5 in W 19 in H 3.4 in)	D 69 cm W 27.6 cm (with feet) W 12.7 cm (w/o feet) H 50.8 (D 27.2 in W 10.8 in (with feet) W 5.0 in (w/o feet) H 20.0 in)							
Maximum Config.	782 W	782 W	79	134	112	190												
Typical Config.	483 W	483 W	61	104	112	190												
ASHRAE Class 1	Airflow cooling scheme (front to rear)						Min config	Two 4 GB DDR2 DIMMs, no PCIe/PCI-X public cards or RAID card on private I/O slot.										
							Max Config	Eight 4 GB DDR2 DIMMs, three PCIe/PCI-X cards on public I/O slots, and RAID card in private slot.										
													Typical Config	Four 4 GB DDR2 DIMMs, one PCIe/PCI-X card on public I/O slots, and RAID card in private slot.				

1 Derate maximum dry bulb temperature 1 degree / 300 meters above 900 meters.

Table 2-7 (page 41) shows the physical and environmental specifications for the Office Friendly server.

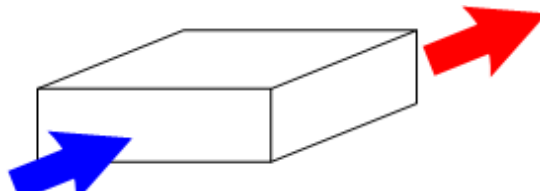

**Table 2-7 Physical and Environmental Specifications of the Office Friendly Server**

	Condition						Weight		Server Dimensions
	Typical Heat Release		Nominal Airflow		Maximum Airflow @ 35 degrees C <sup>1</sup>		Server	Pedestal	Pedestal
	100-127 VAC	200-240 VAC							
	Watts	Watts	CFM	m3/hr	CFM	m3/hr	21 kg - 28 kg (46 lb - 61 lb)	30 kg - 37 kg (66 lb - 81 lb)	D 69 cm W 27.6 cm (with feet) W 12.7 cm (w/o feet) H 50.8 (D 27.2 in W 10.8 in (with feet) W 5.0 in (w/o feet) H 20.0 in)
Minimum Config.	363 W	363 W	45	76	162	275			
Maximum Config.	782 W	782 W	45	76	162	275			
Typical Config.	483 W	483 W	45	76	162	275			
ASHRAE Class 1	Airflow cooling scheme (front to rear)					Min Config	Two 4 GB DDR2 DIMMs, no PCIe/PCI-X public cards or, RAID card on private I/O slot.		
						Max Config	Eight 4 GB DDR2 DIMMs, three PCIe/PCI-X cards on public I/O slots, and RAID card in private slot.		
						Typical Config	Four 4 GB DDR2 DIMMs, one PCIe/PCI-X card on public I/O slots, and RAID card in private slot.		

<sup>1</sup> Derate maximum dry bulb temperature 1 degree / 300 meters above 900 meters.

---

## 3 Installing the Server

This chapter provides information and procedures to install the server, and addresses the following topics:

- “Safety Information” (page 42)
- “Installation Sequence and Checklist” (page 43)
- “Unpacking and Inspecting the Server” (page 43)
- “Installing Additional Components” (page 45)
- “Installing the Server into a Rack or Pedestal” (page 64)
- “Connecting the Cables” (page 65)
- “Connecting and Setting Up the Console” (page 67)
- “Accessing the Host Console” (page 76)
- “Powering On and Powering Off the Server” (page 78)
- “Verifying Installed Components In the Server” (page 80)
- “Installation Troubleshooting” (page 83)

### Safety Information

Use care to prevent injury and equipment damage when performing removal and replacement procedures. Voltages can be present within the server. Many assemblies are sensitive to damage by electrostatic discharge (ESD).

Follow the safety conventions listed below to ensure safe handling of components, to prevent injury, and to prevent damage to the server:

- When removing or installing any server component, follow the instructions provided in this guide.
- If installing a hot-swappable or hot-pluggable component when power is applied (fans are running), reinstall the server cover immediately to prevent overheating.
- If installing a hot-pluggable component, complete the required software intervention prior to removing the component.
- If installing an assembly that is neither hot-swappable nor hot-pluggable, disconnect the power cable from the external server power receptacle before starting the installation.



**WARNING!** Ensure that the system is powered off and all power sources are disconnected from the server prior to removing or installing server hardware (unless you are removing or installing a hot-swappable or hot-pluggable component).

Voltages are present at various locations within the server whenever an ac power source is connected. This voltage is present even when the main power switch is off.

Failure to observe this warning can result in personal injury or equipment damage.

---

- Do not wear loose clothing that can snag or catch on the server or on other components.
- Do not wear clothing subject to static charge buildup, such as wool or synthetic materials.
- If installing an internal assembly, wear an antistatic wrist strap and use a grounding mat, such as those included in the Electrically Conductive Field Service Grounding Kit (HP 9300-1155).
- Handle accessory boards and components by the edges only. Do not touch any metal edge connectors or any electrical components on accessory boards.

# Installation Sequence and Checklist

Table 3-1 lists the server installation steps. Follow these steps in sequence to complete a successful installation.

**Table 3-1 Installation Sequence Checklist**

Step	Description	Completed
1	Unpack and inspect the server shipping container. Inventory the contents using the packing slip.	
2	Install any additional components shipped with the server.	
3	Install the server into a rack or pedestal.	
4	Connect cables to the server.	
	a: Connect ac input power cable.	
	b: Connect LAN core I/O cable.	
5	Connect and set up the console for access.	
6	Power on the server.	
7	Access the console.	
8	Verify components in the server.	
9	Boot the operating system.	
10	Verify the server configuration.	

## Unpacking and Inspecting the Server

This section describes procedures you perform before installation. Ensure that you have adequately prepared your environment for the new server, received the components that you ordered, and verified that the server and its containers are in good condition after shipment.

This section addresses the following topics:

- “Verifying Site Preparation” (page 43)
- “Inspecting the Shipping Containers for Damage” (page 44)
- “Unpacking the Server” (page 44)
- “Checking the Inventory” (page 44)
- “Returning Damaged Equipment” (page 44)
- “Unloading the Server With a Lifter” (page 44)

## Verifying Site Preparation

Verifying site preparation is an essential factor of a successful server installation, and includes the following tasks:

- Gather LAN information. The IP addresses for the iLO 2 MP LAN and the system LAN are located on the right side of the server near the bezel, above the rack mounting rail.
- Establish a method to connect to the server console.
- Verify electrical requirements. Ensure that grounding specifications and power requirements are met.
- Validate server physical space requirements.
- Confirm environmental requirements.

For server-specific information on electrical, physical space, and environmental requirements, see Chapter 2 (page 36). For general site preparation information, see the *HP Generalized Site Preparation Guide* on the HP website at <http://docs.hp.com>.

## Inspecting the Shipping Containers for Damage

HP shipping containers protect their contents under normal shipping conditions. After the equipment arrives, carefully inspect each carton for signs of shipping damage. Shipping damage constitutes moderate to severe damage, such as punctures in the corrugated carton, crushed boxes, or large dents. Normal wear or slight damage to the carton is not considered shipping damage. If you find shipping damage to the carton, contact your HP customer service representative immediately.

## Unpacking the Server

To unpack the server, follow these steps:

1. Follow the instructions printed on the outside top flap of the carton to remove the banding and the outer carton from the server pallet.
2. Remove all inner accessory cartons and the top foam cushions, leaving only the server.



---

**IMPORTANT:** Inspect each carton for shipping damage as you unpack the server.

---

## Checking the Inventory

The sales order packing slip lists all the equipment shipped from HP. Use this packing slip to verify that all of the equipment has arrived.



---

**NOTE:** To identify each item by part number, refer to the sales order packing slip.

---

## Returning Damaged Equipment

If the equipment is damaged, contact your HP customer service representative immediately. The service representative initiates appropriate action through the transport carrier or the factory and assists you in returning the equipment.

## Unloading the Server With a Lifter



---

**WARNING!** Use caution when using a lifter. Because of the weight of the HP Integrity rx2660 server, you must center the server on the lifter forks before lifting it off the pallet to avoid injury.

---



---

**NOTE:** HP recommends that you follow your local guidelines when lifting equipment.

---

To unload the server from the pallet using a lifter (if necessary), follow these steps:

1. Unpack the server.
2. Unroll the bottom corrugated tray corresponding to the side on which the lifter will be placed, and slide the server as close to that edge of the pallet as possible.
3. Break off any foam packaging that can prevent the lifter from being fully inserted under the server. Do not remove the foam packaging from the corners of the server. This foam is required to elevate the server and to enable the forks of the lifter to be placed under the server.
4. Insert the lifter forks under the server.
5. Carefully roll the lifter forward until it is fully positioned against the side of the server.
6. Slowly raise the server off the pallet until it clears the pallet cushions.
7. Carefully roll the lifter and server away from the pallet. Do not raise the server any higher than necessary when moving it over to the rack.

# Installing Additional Components

This section describes how to install components into the server that are not factory-installed. If you have additional components to install, be sure to install the additional components before installing the server into your rack or pedestal configuration. Most servers are pre-configured with all components installed prior to shipping from the HP factory.

This section addresses the following topics:

- “Introduction” (page 45)
- “Installing a SAS Hard Drive” (page 45)
- “Installing a Hot-Swappable Power Supply” (page 47)
- “Removing the Top Cover” (page 48)
- “Removing the Airflow Guide” (page 49)
- “Installing System Memory” (page 51)
- “Installing a Processor” (page 52)
- “Replacing the Airflow Guide” (page 57)
- “Installing Additional PCIe/PCI-X Cards” (page 58)
- “Installing the SAS Smart Array and PCIe Expansion Boards” (page 61)
- “Replacing the Top Cover” (page 63)

## Introduction

The rx2660 server contains external components (installable without removing the top cover), and internal components that are accessed by removing the top cover.

The externally accessible components are as follows:

- SAS hard drives
- Power supplies

The internal components are as follows:

- System memory
- Processors
- PCIe/PCI-X cards



**WARNING!** Ensure that the system is powered off and all power sources are disconnected from the server prior to removing or installing server hardware (unless you are removing or installing a hot-swappable or hot-pluggable component).

Voltages are present at various locations within the server whenever an ac power source is connected. This voltage is present even when the main power switch is turned off.

Failure to observe this warning can result in personal injury or damage to the equipment.

---

## Installing a SAS Hard Drive

There are eight hot-pluggable SAS hard drive slots located on the front of the server. Slots without SAS hard drives installed have slot fillers installed for cooling purposes.

### Removing a SAS Hard Drive Filler

To install a SAS disk drive you must first remove the hard drive filler. To remove a hard drive filler, follow these steps:

1. Squeeze the tabs on the front of the filler to release it from the slot in the drive bay (1).

2. Pull gently until the filler slides out of the server (2).

**Figure 3-1 Removing a Hard Drive Filler**

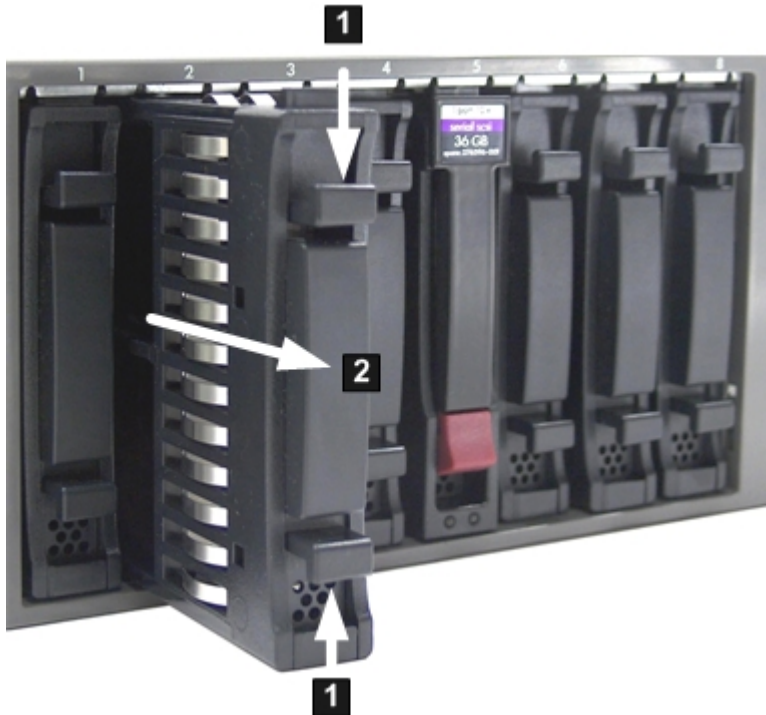

---

**NOTE:** SAS hard drives are loaded in order, starting with slot 8, going from right to left, to slot 1.

Save the SAS hard drive filler for future use. For airflow purposes, always place hard drive fillers in slots that do not contain SAS disk drives.

---

## Installing a SAS Hard Drive

Figure 3-2 (page 47) shows how to install a SAS hard drive.

To install a SAS hard drive, follow these steps.

1. Insert the hard drive into the slot guides, and slide the drive into the slot until it seats into the socket on the disk backplane (1).

2. Close the drive extraction handle by pushing it downward until it clicks into place (2).

**Figure 3-2 Installing a SAS Hard Drive**

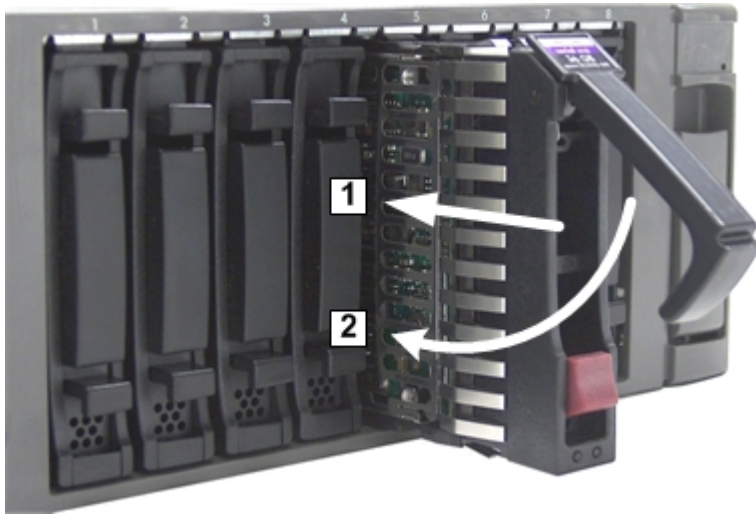

## Installing a Hot-Swappable Power Supply

The Data Center server has at least one hot-swappable power supply installed before shipping. This power supply is located at the rear of the server. You can install a second, optional power supply to provide 1+1 capability. Use the following procedures to install an additional power supply.



**NOTE:** If you have an Office Friendly server, you have two power supplies already installed. You do not need to perform this procedure.

---



**CAUTION:** Observe all ESD safety precautions before attempting this procedure. Failure to follow ESD safety precautions can result in damage to the server.

---



**NOTE:** The power supply is a hot-swappable device. It does not require interaction with the operating system before it is removed from or installed into the server.

---

## Power Supply Loading Guidelines

The supported configuration of the server requires a minimum of one power supply installed in slot P1. The right slot (viewed from the rear of the server) is slot P1, and the left slot is P2.

**Figure 3-3 Power Supply Location**

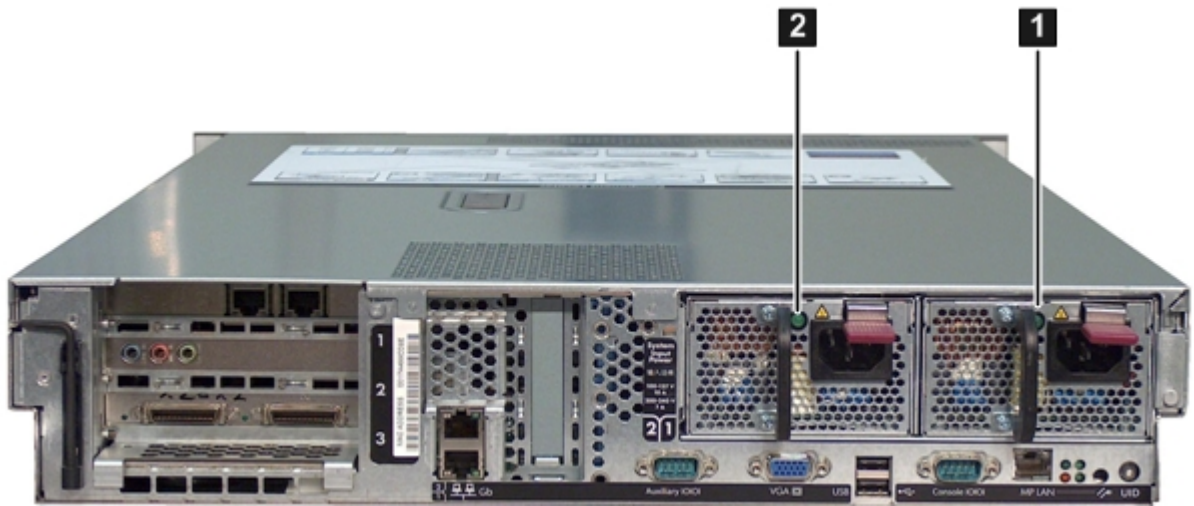

**1** Power supply 1

**2** Power supply 2



**CAUTION:** If you do not purchase a second power supply, the empty power supply slot must remain covered with the supplied metal filler panel. Failure to observe this caution can result in server shutdown due to overheating.

### Installing a Power Supply

Figure 3-4 (page 48) shows how to install a power supply.

To install a power supply, follow these steps.

1. Remove the metal slot filler by pulling it straight out of the server using the finger holes (1).
2. Support the power supply with both hands, and slide it into the empty slot until it clicks into place (2)..



**IMPORTANT:** Ensure the power supply is flush with the adjacent power supply.

**Figure 3-4 Installing a Power Supply**

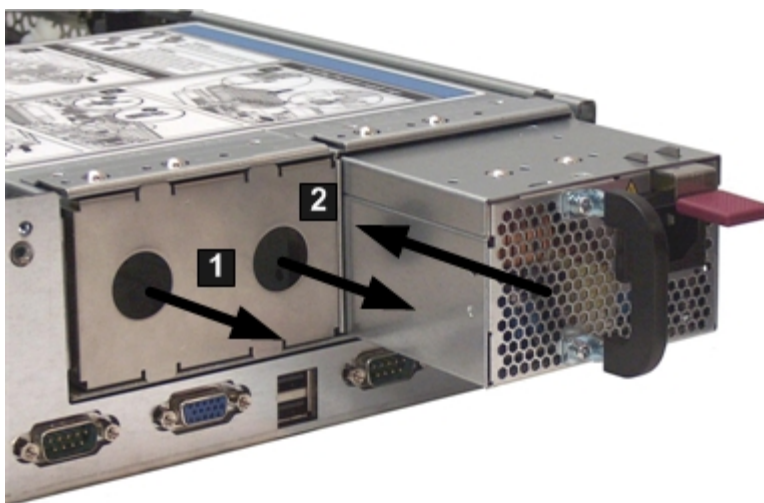

### Removing the Top Cover

When installing internal components into the server, you must first remove the top cover. Figure 3-5 (page 49) shows how to remove the top cover.



To remove the top cover, follow these steps.

1. Unlock the cover release lever (if necessary) by turning the cam approximately 90 degrees counterclockwise with the Allen wrench provided on the rear panel of the server (1).
2. Pull up on the cover release lever to disengage the top cover from the chassis (2).
3. Slide the cover toward the rear of the server until the tabs release from the slots in the chassis (3).
4. Lift the cover off the chassis (4).

**Figure 3-5 Removing the Top Cover**

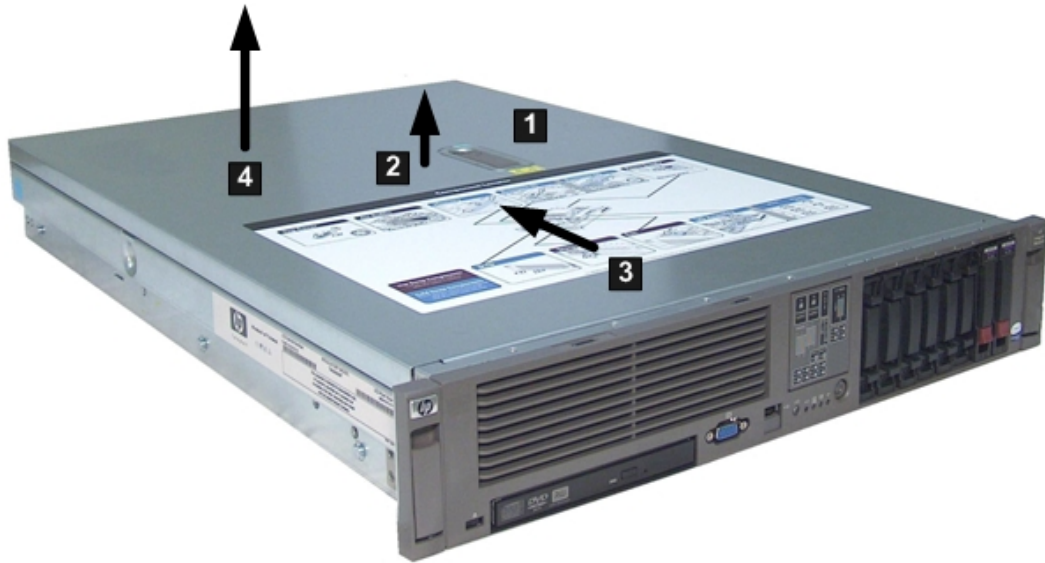

## Removing the Airflow Guide

The airflow guide in the rx2660 server directs airflow from eight of the system fans to the processors and the system memory on the system board. To install an additional processor or system memory, you must remove the airflow guide (and optionally, the RAID battery).

To remove the airflow guide from the server, follow these steps:

1. Remove the top cover.

2. If the RAID battery is connected to the airflow guide, remove it before removing the airflow guide. To remove the RAID battery, follow these steps:
  - a. Pull the RAID battery lock away from the RAID battery (1).
  - b. Slide the RAID battery toward the front of the server to disengage it from the airflow guide (2).
  - c. Pull straight up on the RAID battery to remove it from the airflow guide.

**Figure 3-6 Removing the Airflow Guide**

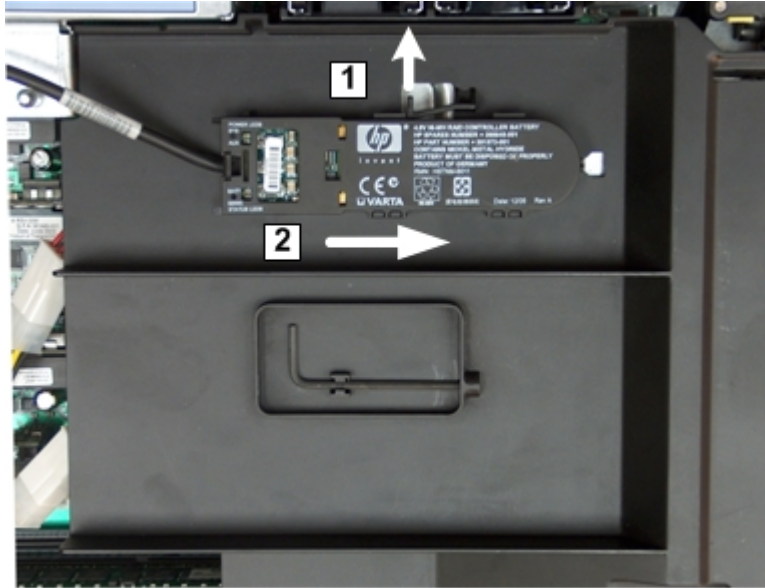

3. Lift up on the fan carrier handle approximately 5 cm (2 in) to allow the airflow guide to be lifted out of the server (1).
4. Lift the airflow guide straight up and out of the server (2). Figure 3-7 (page 50) shows the Data Center fan carrier.

**Figure 3-7 Fan Carrier Handle**



## Installing System Memory

The rx2660 server has eight system memory (DIMM) slots located on the system board.



**CAUTION:** Observe all ESD safety precautions before attempting this procedure. Failure to follow ESD safety precautions can result in damage to the server.

### Memory Installation Conventions

Before installing memory, read and understand the following memory installation conventions:

- Supported DIMM sizes and memory configurations
- DIMM load order
- DIMM slot IDs

#### Supported DIMM Sizes

System DIMMs seat onto the memory boards. The minimum server configuration requires at least one memory pair (group of two DIMMs).

The supported DIMM sizes for the server are as follows:

- 512 MB
- 1 GB
- 2 GB
- 4 GB

#### Memory Pairs

When installing memory, use a minimum of one pair of like-sized DIMMs. You can install additional DIMMs later. Install DIMMs into the appropriate slots on the system board; each slot has a unique ID. Figure 3-8 (page 51) shows the DIMM slot IDs.

**Figure 3-8 Memory Location and Slot IDs**



**CAUTION:** Failure to observe the following cautions results in system degradation or failure:

- Do not mix DIMM sizes or types within a pair.
- Load DIMM pairs in order of size from largest to smallest. For example, if you have a pair of 4 GB DIMMs and a pair of 1 GB DIMMs, install the pair of 4 GB DIMMs first.

Table 3-2 lists the memory load order.

**Table 3-2 Memory Load Order**

Pair Number	Memory Slots
1	0A; 0B
2	1A; 1B
3	2A; 2B
4	3A; 3B

### Memory Loading Rules and Guidelines

Use the following rules and guidelines when installing memory:

- Install DIMMs in pairs
- Ensure that DIMMs within a pair are identical
- Install DIMM pairs in order of size from largest to smallest
- Install DIMM pairs in the specified order shown in Table 3-2

### Installing Memory

To install memory, follow these steps:

1. Remove the top cover from the server. See “Removing the Top Cover” (page 48).
2. Remove the airflow guide. See “Removing the Airflow Guide” (page 49).
3. Complete the following memory installation prerequisite tasks before installing the memory:
  - a. Determine the DIMM load order. For more information, see “Memory Load Order” (page 52).
  - b. See Figure 3-8 (page 51) to determine which DIMM slots to populate.
  - c. Read, understand, and follow the general guidelines to install memory in the server..
4. Install each DIMM.
  - a. Align the DIMM with the slot located on the memory board, and align the key in the connector with the notch in the DIMM.
  - b. Firmly and evenly push on each end of the DIMM until it seats into the slot.
  - c. Ensure the extraction levers are in the fully closed position.
5. Replace the airflow guide if you are finished installing additional components. See “Replacing the Airflow Guide” (page 57).
6. Replace the top cover if you are finished installing additional components. See “Replacing the Top Cover” (page 63). Otherwise, continue with installing components.

### Installing a Processor

The rx2660 server utilizes single- or dual-core processors. Dual-core processors contain two cores that function as separate processors. Dual-core processors double the processing power of the processor while maintaining the physical dimensions of a single processor.

The server holds one or two single- or dual-core processors that provide the following configuration options:

- 1P/1C (One processor / one core)
- 1P/2C (One processor / two cores)
- 2P/2C (Two processors / two cores)
- 2P/4C (Two processors / four cores)

The server has one processor installed in slot Module 0 before shipping. Install the additional processor in slot Module 1.



**CAUTION:** Intel Montvale processors cannot be intermixed with similar Montecito processors. Processor speed and cache size must be identical for all processors in a system. To ensure compatibility whether upgrading, replacing, or adding an additional processor, use processors with identical part numbers.

Failure to observe this caution results in performance degradation or system failure.

To ensure compatibility, use processors with identical part numbers.

**CAUTION:** Observe all ESD safety precautions before attempting this procedure. Failure to follow ESD safety precautions can result in damage to the server.

## Processor Load Order

The server holds up to two single- or dual-core processors on the processor board. The slots on the processor board are labeled Module 0 and Module 1. If the server has only one processor, it is installed in slot Module 0. Install the second processor in slot Module 1.

Table 3-3 lists the processor load sequence.

**Table 3-3 rx2660 Processor Load Order**

Processor	Slot
0	Module 0
1	Module 1

## Required Tools

To install processors, use the processor install tool fastened to the airflow guide.



**TIP:** Prior to installing a processor into the server, read the following instructions carefully and refer to the figures in this chapter for a complete understanding of this process.

To install a processor, follow these steps:

1. Remove the top cover. See “Removing the Top Cover” (page 48)
2. Remove the airflow guide. See “Removing the Airflow Guide” (page 49)

3. Open the processor cage.
  - a. Grasp the processor cage handle and apply adequate force to rotate the handle upward. Figure 3-9 (page 54) shows the processor cage handle open.

**Figure 3-9 Processor Cage Handle**

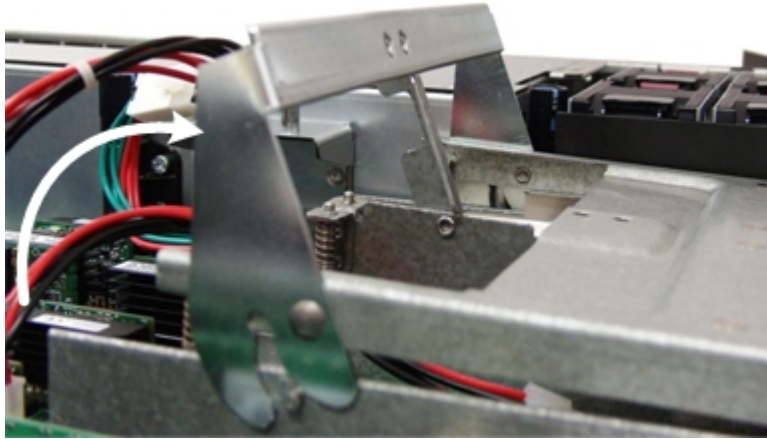

- b. Use the handle to rotate the cage closure approximately 90 degrees toward the front of the assembly until it stops. Figure 3-10 (page 54) shows the processor cage fully open.

**Figure 3-10 Processor Cage Open**

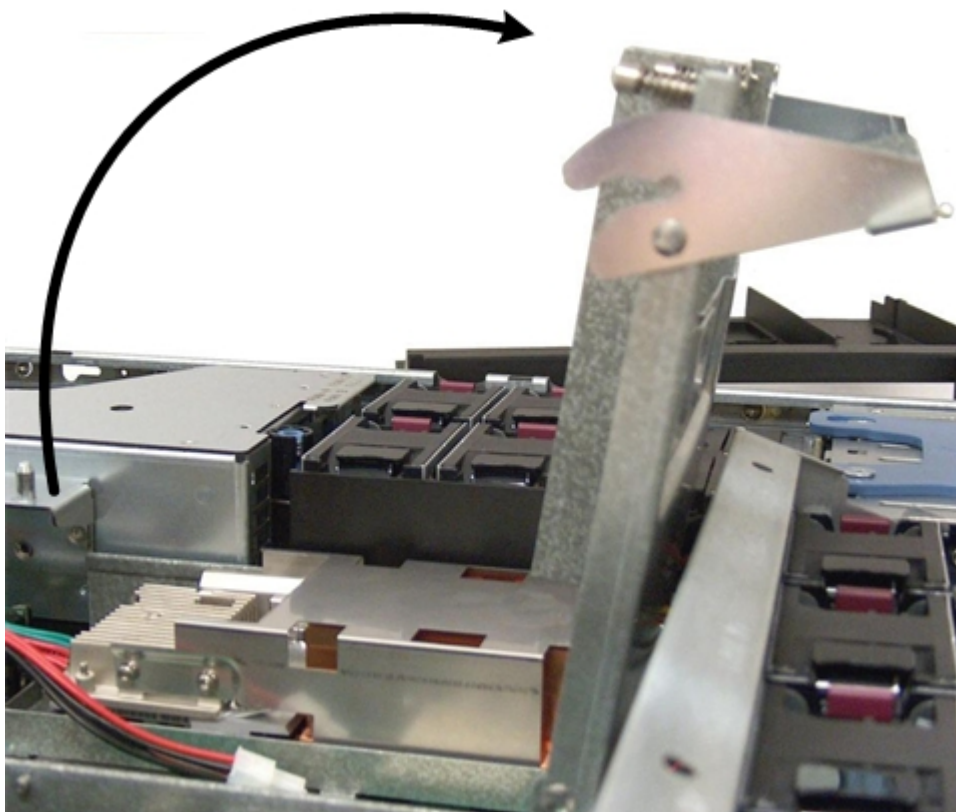

---

**IMPORTANT:** Ensure the processor slot is entirely exposed. The processor must clear the cage enclosure for proper installation.

---

4. Locate the slot Module 1 on the system board for the processor installation. Figure 3-11 (page 55) shows the slot locations on the system board.

**Figure 3-11 ZIF Socket, Alignment Holes and Posts, and Slot Locations**

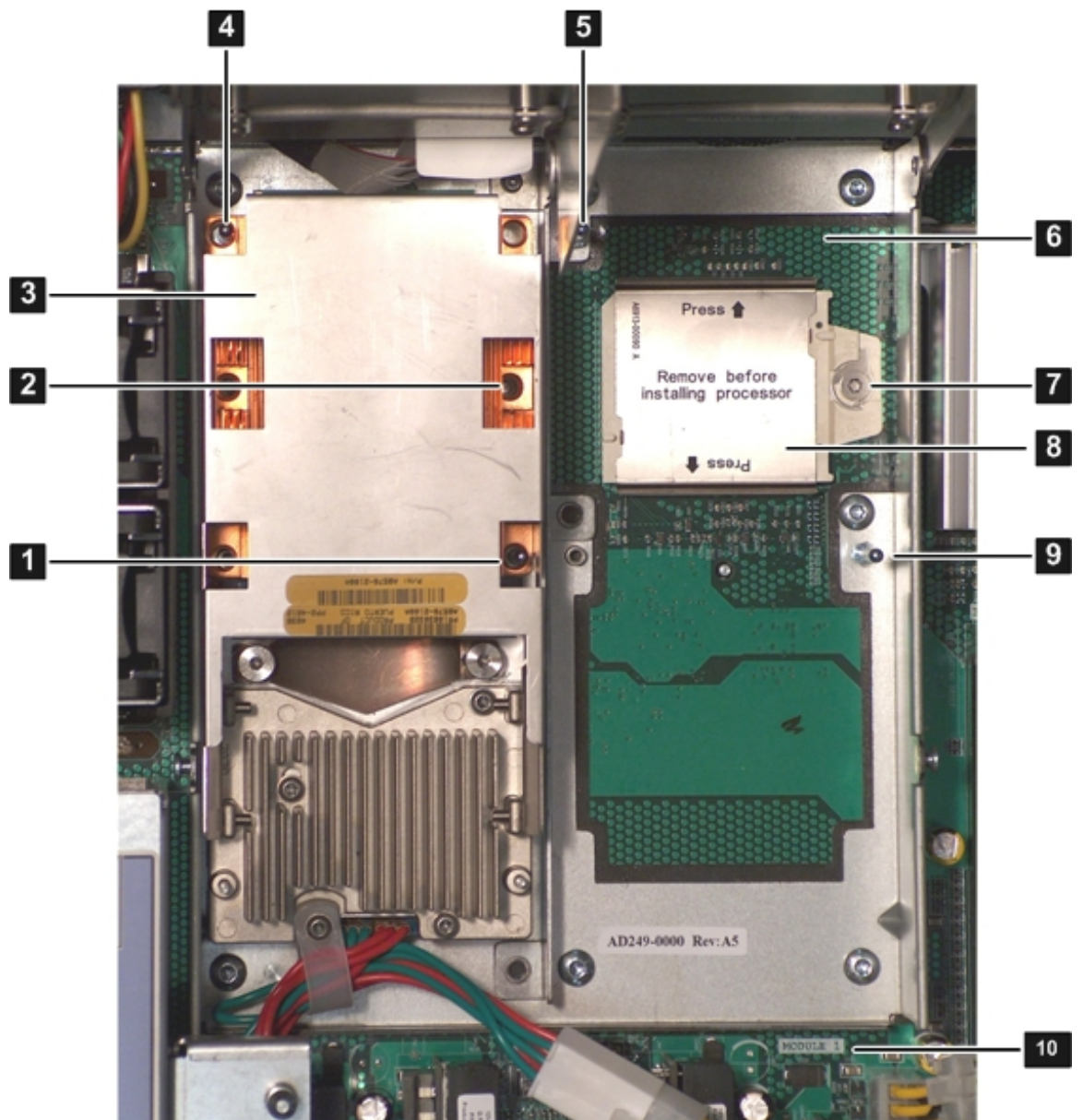

- |          |                                    |           |   |
|----------|------------------------------------|-----------|---|
| <b>1</b> | Alignment hole on the processor    | <b>6</b>  | Processor slot 1 on the system board (Module 1) |
| <b>2</b> | Access hole for the ZIF socket     | <b>7</b>  | ZIF socket on the system board                  |
| <b>3</b> | Processor 0                        | <b>8</b>  | Processor socket dust cover                     |
| <b>4</b> | Alignment hole on the processor    | <b>9</b>  | Alignment post on the system board              |
| <b>5</b> | Alignment post on the system board | <b>10</b> | Module 1 label on the system board              |

5. Remove the plastic airflow blocker covering the processor slot (if installed).
6. Remove the protective dust cover from the processor socket (if installed).
7. Ensure the cam on the ZIF socket is in the unlocked, counterclockwise position. Figure 3-12 (page 56) shows the unlocked ZIF socket.

**Figure 3-12 ZIF Socket**

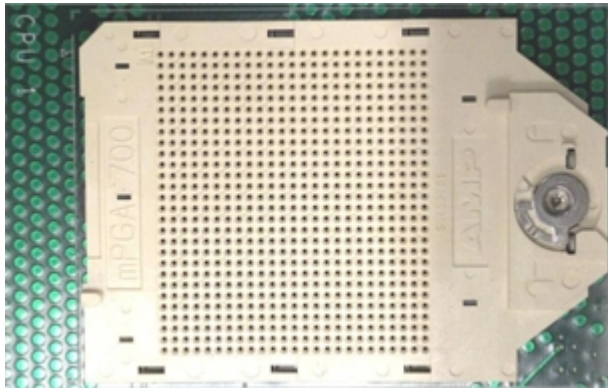

---

**CAUTION:** The ZIF socket for the processor is locked and unlocked by half a full turn of the processor install tool. The counterclockwise 180 degree rotation (half turn) unlocks the socket. A clockwise 180 degree rotation locks the socket. Attempting to turn the locking mechanism more than 180 degrees can severely damage the socket.

---

8. Remove any protective packaging from the processor.
- 



**NOTE:** Protective covers are installed to protect connector pins. Save these covers for future use.

---

9. Inspect the processor pins to verify the pins are not bent.
  10. Align the alignment holes on the processor with the alignment posts on the processor cage, and carefully lower the processor onto the processor socket. [Figure 3-11 \(page 55\)](#) shows the alignment holes and posts on the processor and system board.
- 



**CAUTION:** Do not press the processor into the socket. When properly aligned, the processor pins seat into the socket. No additional pressure is required. Damage to the pins may occur if pressure is applied.

---

11. Lock the processor into the socket on the processor board.
  - a. Remove the processor install tool (2.5 mm driver) from the tool holder on the airflow guide.
  - b. Insert the processor tool into the hole that runs down the side of the heatsink.
  - c. Rotate the processor tool clockwise 180 degrees to lock the ZIF socket.
  - d. Refasten the processor install tool (2.5 mm driver) to the tool holder on the airflow guide.
12. Connect the processor power cable into the connector cable that attaches directly to the system board. [Figure 3-13 \(page 57\)](#) shows the processor power cable connectors.



**Figure 3-13 Processor Power Connectors**

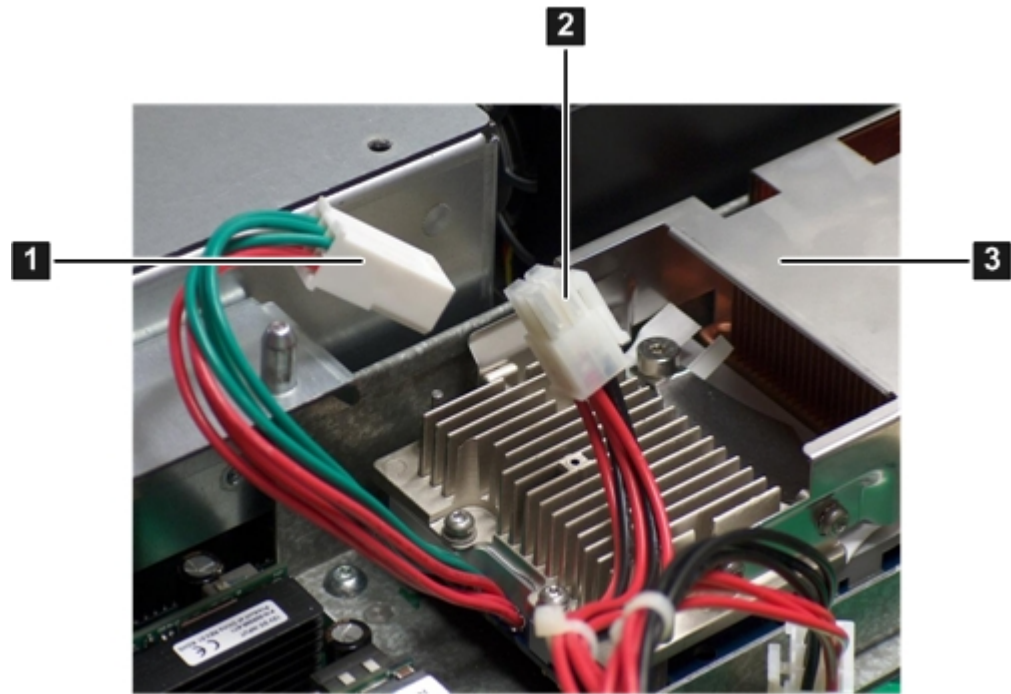

**1** Processor power cable and connector

**2** System board power cable and connector

**3** Processor

13. Close the processor cage.
  - a. Grasp the processor cage handle and rotate the cage closure inward toward the rear of the assembly until it is completely closed.
  - b. Apply adequate force to push the handle down until it is flush with the cage.
14. Replace the airflow guide if you are finished installing additional components. See “Replacing the Airflow Guide” (page 57).
15. Replace the top cover if you are finished installing additional components. See “Replacing the Top Cover” (page 63)

## Replacing the Airflow Guide

Use this procedure to replace the airflow guide in the server when you are finished installing additional equipment into the server.

To replace the airflow guide, follow these steps:

1. Ensure the fan carrier handle is raised approximately 5 cm (2 in) to allow clearance for the airflow guide replacement. Figure 3-14 (page 58) shows the fan carrier handle raised.
2. Place the airflow guide on the edge of the fan carrier and set it down into place on the processor cage (1).
3. Push the fan carrier handle down until it is flush against the airflow guide (2).

**Figure 3-14 Replacing the Airflow Guide**

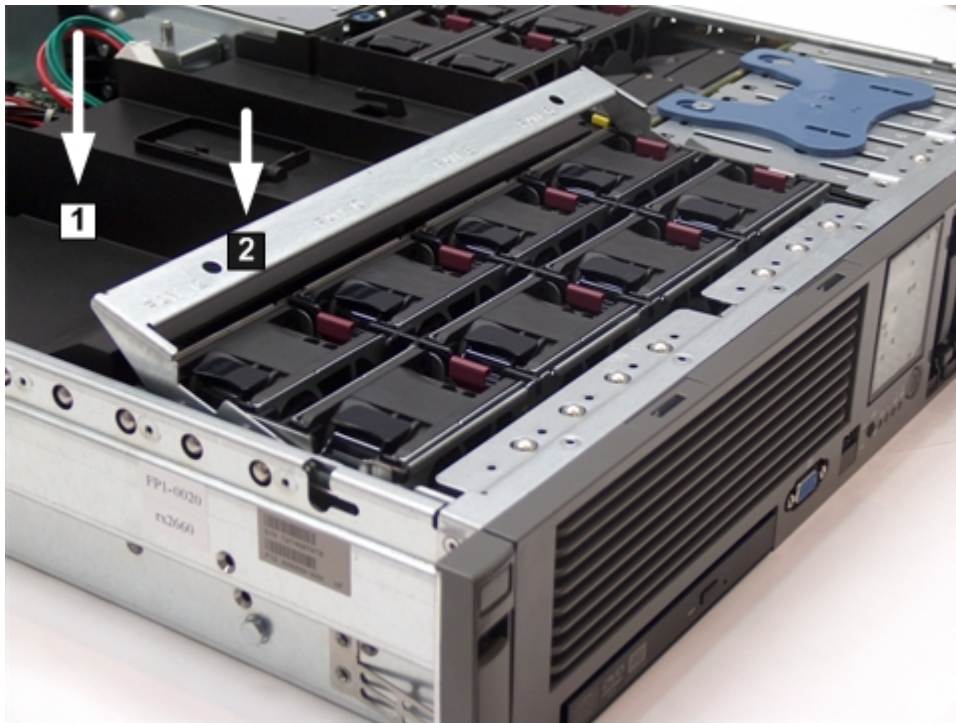

4. Ensure the fans have not become disconnected when opening the fan carrier handle by pushing down on all the fans to make sure they are seated properly.

## Installing Additional PCIe/PCI-X Cards

The rx2660 server supports PCI-X cards and PCI-Express (PCIe) cards. There are three PCIe/PCI-X slots in the I/O backplane located on the system board. Depending on your server configuration, you have one of the following I/O backplane assemblies, with the included riser board:

**PCI-X riser board:**

Three full-length PCI-X public slots

**PCIe/PCI-X riser board:**

Two PCIe x8 public slots and one full-length PCI-X public slot



**NOTE:** Wake-on-LAN is not enabled on any of the PCIe/PCI-X slots.

PCIe/PCI-X hot-plugging is not supported on the rx2660 server.

---

## Removing the I/O Backplane from the Server

To install an additional PCIe/PCI-X card into the server, you must first remove the I/O backplane from the system board.

To remove the I/O backplane assembly, follow these steps:

1. Remove the top cover. See “Removing the Top Cover” (page 48).

2. Loosen the two captive screws on the I/O backplane assembly. Follow these steps to loosen the captive screws:
  - a. Press the blue button to release the black knob. Figure 3-15 (page 59) shows the location of the I/O backplane assembly captive screws.
  - b. Turn the black knob counterclockwise until the captive screw is free from the server.

**Figure 3-15 I/O Backplane Assembly Screw Locations**

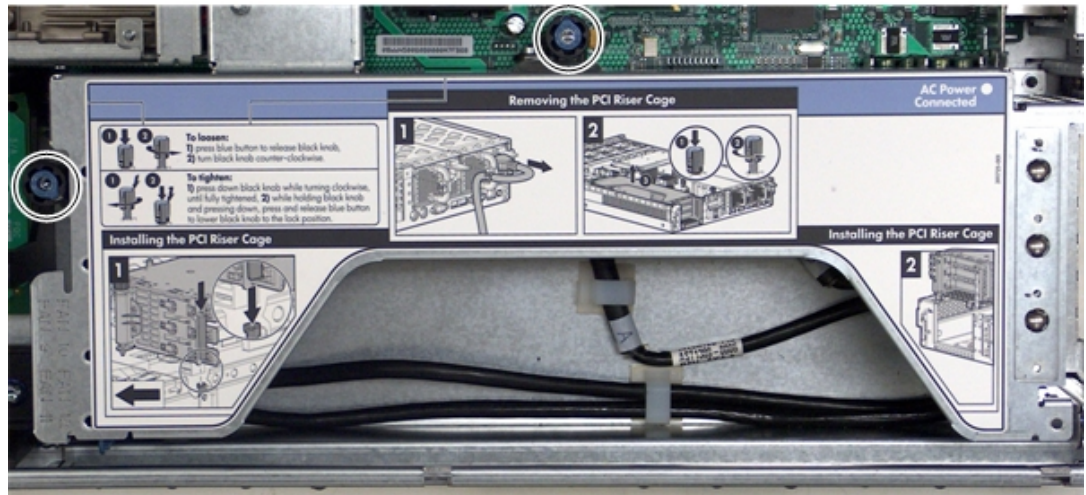

3. Lift the assembly straight up and out of the server.



**NOTE:** Depending on your configuration, you have one of the I/O backplane assemblies shown in Figure 3-16 (page 60). The top I/O backplane assembly is a PCIe/PCI-X backplane assembly, and the bottom is a PCI-X backplane assembly.

**Figure 3-16 I/O Backplane Assemblies**

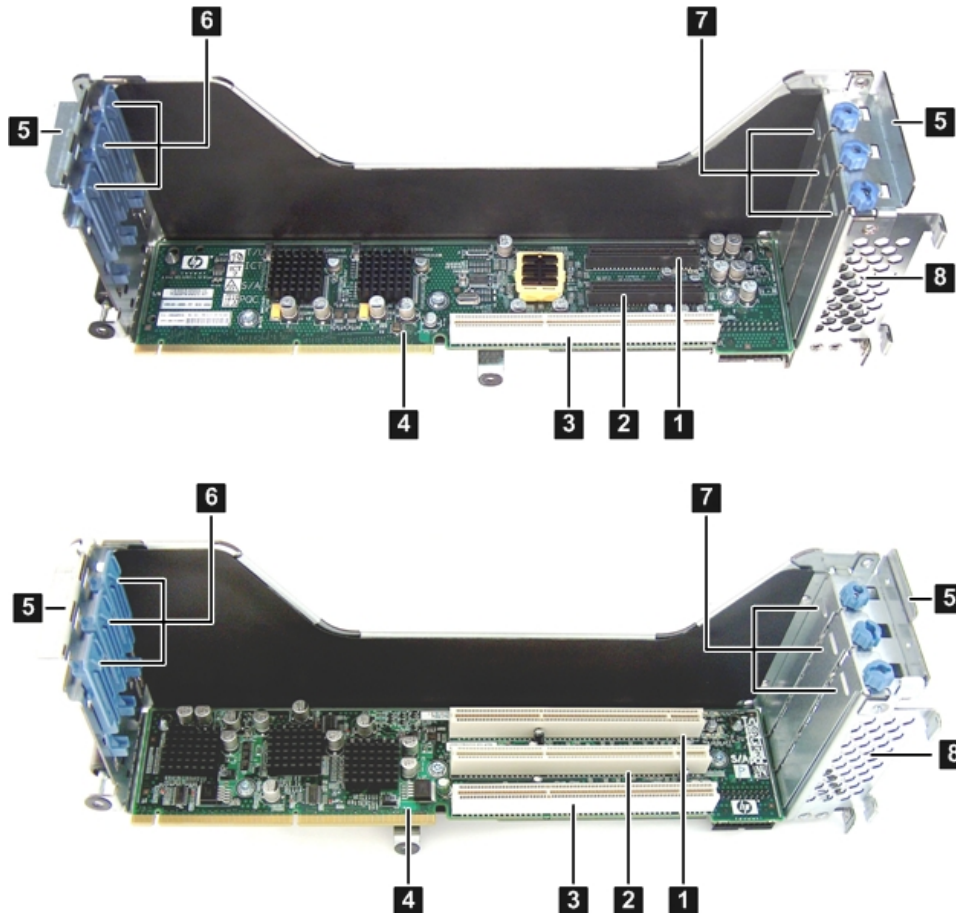

- |  |   |
|--|---|
| <b>1</b> Slot 1 (top, PCIe; bottom PCI-X)                    | <b>5</b> Guide tabs                           |
| <b>2</b> Slot 2 (top, PCIe; bottom PCI-X)                    | <b>6</b> Gate latches (for full-length cards) |
| <b>3</b> Slot 3 (PCI-X)                                      | <b>7</b> Bulkhead fillers                     |
| <b>4</b> I/O backplane riser board (top, PCIe; bottom PCI-X) | <b>8</b> Sheet metal enclosure                |

### Installing a PCIe/PCI-X Card

To install a PCIe/PCI-X card, follow these steps:

1. Select an empty slot that is appropriate for the card you are installing. X shows both a PCI-X and PCIe/PCI-X riser boards.
2. Remove the PCIe/PCI-X bulkhead filler by unscrewing the blue captive screw using a Torx-T15 screwdriver.

3. Insert the PCIe/PCI-X card into the empty slot, and exert even pressure to seat the card in the slot.



---

**CAUTION:** Ensure that you fully seat the card into the slot or the card can fail after power is applied to the slot.

---

4. Close the gate latch to secure the end of the card if it is full length.
5. Attach the PCIe/PCI-X card to the I/O backplane by tightening the T-15 screw on the I/O backplane.

## Replacing the I/O Backplane Card Cage

To replace the I/O backplane card cage into the server, follow these steps:

1. Align the tabs with the guide slots in the server and slide the I/O backplane assembly into place.
2. Tighten the two captive screws.
  - a. Press the black knob down while turning it clockwise until it is fully tightened.
  - b. While holding the black knob and pressing down, press and release the blue button to lower the black knob to the locked position.
3. If you are done installing additional components, replace the top cover. See “Replacing the Top Cover” (page 63). If you have more components to install, continue on to the next section.

## Installing the SAS Smart Array and PCIe Expansion Boards

The rx2660 server has two slots dedicated for the SAS Smart Array P400 controller and PCIe expansion boards. If you purchase the RAID option, you must install these boards on the system board. See for the slot locations on the system board.

### Installing the PCIe Expansion Board

To install the PCIe expansion board into the server, follow these steps:

1. Pinch the board locking guides to expose the slot guides to the system board slot (1). Figure 3-17 (page 62) shows the location of the SAS Smart Array P400 controller and PCIe expansion board.
2. Guide the PCIe expansion board down the rails and push into the slot on the system board (2).

**Figure 3-17 SAS Smart Array P400 Controller and PCIe Expansion Board Slots**

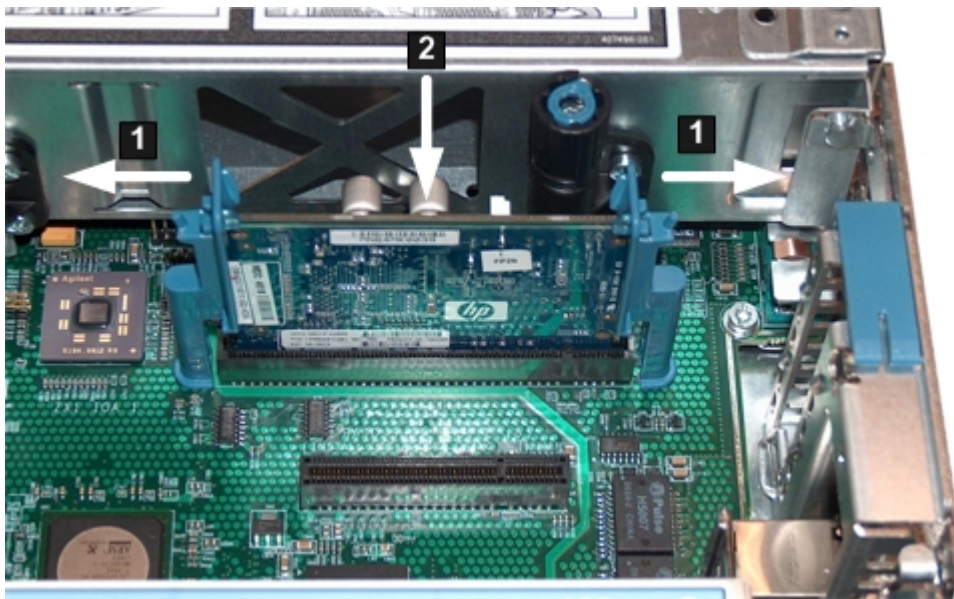

**NOTE:** The board and slot are keyed, so the board only fits one way into the slot.

3. Close the board locking guides to lock the PCIe expansion board into place on the system board.

### Installing the SAS Smart Array P400 Controller and RAID Battery

To install the SAS Smart Array P400 controller and the battery into the server, follow these steps:

1. Open the blue SAS Smart Array P400 controller board lock on the rear panel of the server. See Figure 3-18 (page 62) shows the location of the board lock.
2. Install the SAS Smart Array P400 controller into the slot on the system board as shown in Figure 3-18 (page 62).
3. Close the board lock over the tab on the SAS Smart Array P400 controller and snap it shut.
4. Attach the SAS cables to the SAS Smart Array P400 controller.

**Figure 3-18 Board Lock**

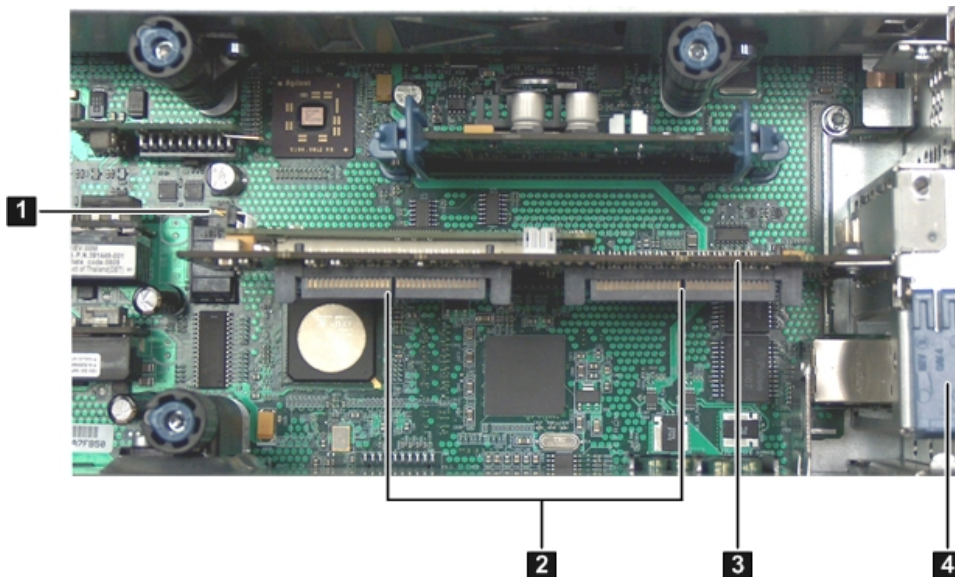

- 1 RAID battery port on the SAS Smart Array controller
  - 2 SAS Smart Array P400 controller board lock
  - 3 SAS Smart Array P400 controller
  - 4 SAS cable ports on the SAS Smart Array P400 controller
5. To install the RAID battery onto the airflow guide, follow these steps:
- a. Align the tabs on the RAID battery with the slots on the airflow guide.
  - b. Slide the RAID battery toward the rear of the server until the locking clip locks the RAID battery in place (1). Figure 3-19 (page 63) shows how to lock the RAID battery onto the airflow guide.

**Figure 3-19 Installing the RAID battery**

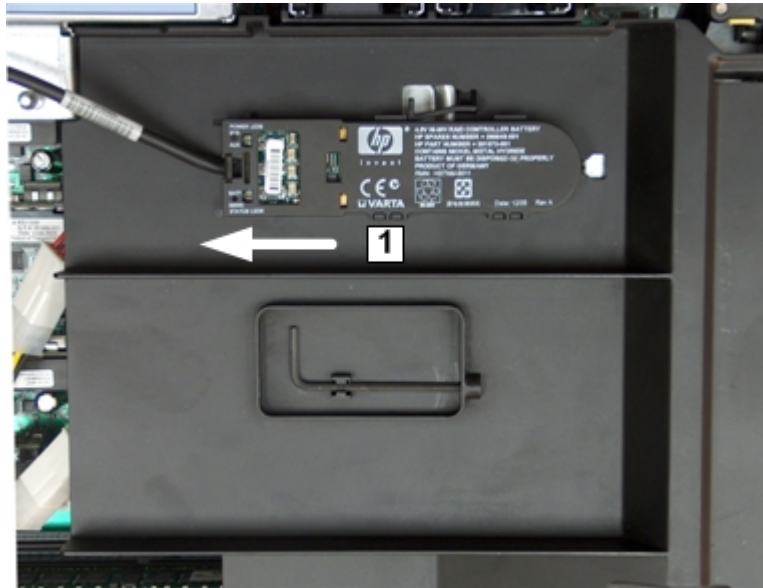

- 6. Connect one end of the RAID battery cable to the battery on the airflow guide.
- 7. Connect the other end of the RAID battery cable to the SAS Smart Array P400 controller.

**CAUTION:** When disconnecting the SAS cables, note the labeling on the cables. When reconnecting these cables, match each cable with the appropriate socket on the SAS Smart Array P400 controller board. If the cables are mismatched, the server may not reboot. Both cables and sockets are clearly marked with the correct channels.

## Replacing the Top Cover

To replace the top cover, follow these steps:

- 1. Ensure the cover release lever is in the open position. Figure 3-20 (page 64) shows how to replace the top cover.
- 2. Align the tabs of the top cover with the corresponding slots in the chassis and insert the tabs into the slots (1).
- 3. Slide the cover forward until it is flush with the front of the chassis (2).
- 4. Push the cover release lever down into the latched position (3).

5. Lock the cover release lever (if necessary) by turning the cam approximately 90 degrees clockwise.

**Figure 3-20 Replacing the Top Cover**

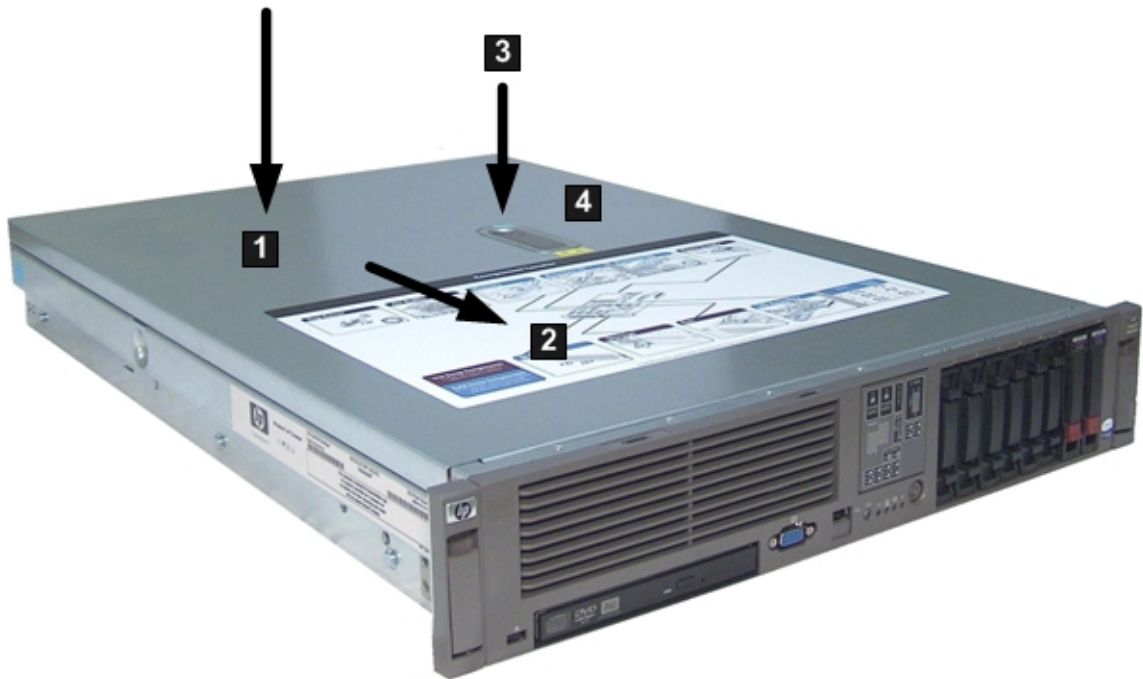

## Installing the Server into a Rack or Pedestal

This section provides instructions on how to install the server into a rack or a pedestal.

### Installing the Server into a Rack

The following sections describe how to install the server into an HP rack or an approved non-HP rack.

#### HP Rack

HP servers that are installed into racks are shipped with equipment mounting slides. An installation guide comes with each set of slides: *HP 2U Quick Deploy Rail System Installation Instructions for HP Products*. Follow the steps in this installation guide to determine where and how to install the server into the rack.

#### Non-HP Rack

The *Mounting in non-HP racks* guide enables you to evaluate the installation of HP equipment into non-HP racks. Use this guide when you need to qualify whether you can install, maintain, and service any HP equipment in a non-HP rack.

The guide is located on the HP website at: <http://www.hp.com/racksolutions> on the HP Integrity and HP 9000 Servers infrastructure page. Click the **Rack Systems/E** link.

Select **Mounting information** from the menu, then select the guide titled *Mounting in non-HP racks*.

### Installing the Server into a Pedestal

The server ships with a pedestal mount if you order the rackless configuration option. The pedestal mount is packaged in a separate carton which is attached to the server carton.



To change the server from a rack mount to a rackless configuration, you need a Server Rackless Mount Kit. The rackless mount kit comes with the *HP Integrity rx2660 Server Pedestal Installation Guide*. Follow the steps in this installation guide to attach the pedestal to the server.

## Connecting the Cables

This section describes the cables to connect to power the server and to provide LAN connectivity for the server.

### ac Input Power

The server can receive ac input from two different ac power sources. The power receptacles are located at the rear of the chassis. They are labeled Power Supply 1 and Power Supply 2.

For the Data Center server, you can install a maximum of two power supplies in the server. Installing two power supplies in the server provides 1+1 redundancy, meaning that if one power supply fails, there is still enough power supplied to the server to operate. You must promptly replace the failed power supply to restore 1+1 functionality.

A minimum of one power supply is required to power the server. If only one power supply is installed in the server, there is no 1+1 capability.

For the Office Friendly server, two power supplies are required to power the server. The office friendly server can run on one power supply, but runs quieter and more efficiently with two power supplies installed.

### Power States

The server has three power states:

- Standby power
- Full power
- Off

Table 3-4 lists the server power states.

**Table 3-4 Power States**

Power States	Power Cable Plugged Into Receptacle?	Power Activated through the iLO 2 MP PC Command; or Front Panel Power Button Activated?	Standby dc Voltage Applied?	dc Voltage Applied?
Standby power	Yes	No	Yes	No
Full power	Yes	Yes	Yes	Yes
Off	No	No	No	No



**CAUTION:** If the server is expected to remain in standby mode for more than 30 minutes, ac power should be completely removed from the server. You can do this by switching off the circuit breakers which are part of the building installation, disconnecting or switching off a power distribution unit, or by physically removing all power cords from the server.



**NOTE:** If the power restore feature is set to **Always On** through the iLO 2 MP PR command, the server automatically powers on to the full power state when the power cord is plugged in to the server.

Figure 3-21 (page 66) shows the ports and power supplies located on the rear panel of the server.

**Figure 3-21 Rear Panel Control, Port, and LED Locations**

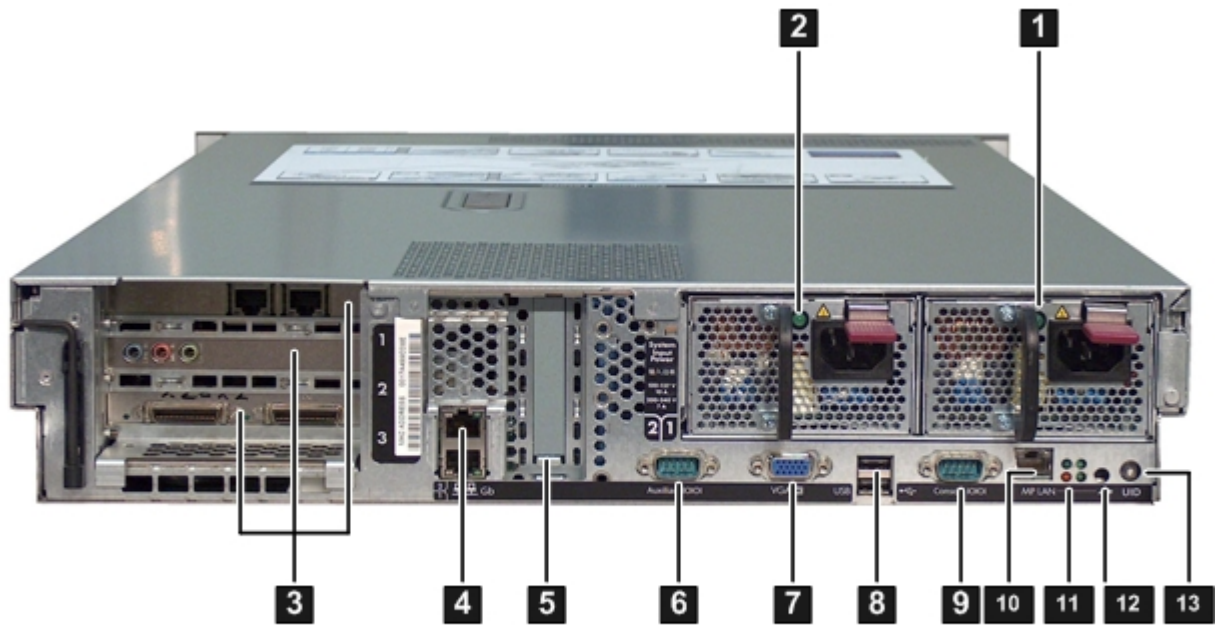

- |   |                                  |   |                       |    |                      |
|---|----------------------------------|---|-----------------------|----|----------------------|
| 1 | Power supply 1 and LED           | 6 | Auxiliary serial port | 10 | iLO 2 MP LAN port    |
| 2 | Power supply 2 and LED           | 7 | VGA port              | 11 | iLO 2 MP status LEDs |
| 3 | PCI-X/PCIe slots                 | 8 | USB ports             | 12 | iLO 2 MP reset       |
| 4 | Core LAN ports                   | 9 | Console serial port   | 13 | UID button/LED       |
| 5 | Smart Array P400 controller slot |   |                       |    |                      |



**NOTE:** The Office Friendly server is shown in Figure 3-21 (page 66). The Data Center server may only have one power supply installed.

### Applying Standby Power to the Server

To apply standby power to the server, follow these steps:

1. If the server has one power supply installed in slot P1, plug the power cord into that receptacle. Plug the other end of the power cord into an appropriate outlet.



**NOTE:** The LED on the power supply does not illuminate in the standby power state. The LED illuminates green when the server is powered on to full power.

If the power restore feature is set to **Always On** through the iLO 2 MP PR command, the server automatically powers on to the full power state when the power cord is plugged into the server.

2. If the server has two power supplies, plug the second power cord into the power supply in slot P2. Plug the other end of the power cord into an appropriate outlet.

### Connecting to the LAN

The server has two LAN ports that provide network connectivity. Figure 3-21 (page 66) shows the available LAN ports for the server.

To enable general network connectivity for the server, follow these steps:

1. Obtain valid IP addresses for each LAN port you plan to activate.

2. Connect the LAN cable from an available LAN port into a live connection on the network.

## Connecting and Setting Up the Console

This section describes how to set up and start a console session on an rx2660 server, and addresses the following topics:

- “Setting Up the Console” (page 67)
- “Setup Checklist” (page 68)
- “Setup Flowchart” (page 69)
- “Preparation” (page 70)
- “Configuring the iLO 2 MP LAN Using DHCP and DNS” (page 71)
- “Configuring the iLO 2 MP LAN Using ARP Ping” (page 72)
- “Configuring the iLO 2 MP LAN Using the RS-232 Serial Port” (page 73)
- “Logging In to the iLO 2 MP” (page 74)
- “Additional Setup” (page 75)

### Setting Up the Console

Setting up the console includes the following steps:

- Determine the physical access method to connect cables. There are two physical connections to the iLO 2 MP:
  - RS-232
  - LAN.
- Configure the Integrity iLO 2 MP and assign an IP address if necessary. Though there are several methods to configuring the LAN, DHCP with DNS is the preferred method. DHCP with DNS comes preconfigured with default factory settings, including a default user account and password. Other options include:
  - ARP Ping
  - Local RS-232 serial port
  - Remote/modem port

## Setup Checklist

Use the checklist in Table 3-5 to assist with the Integrity iLO 2 MP setup process.

**Table 3-5 Setup Checklist**

	Step	Action	X
<i>Standard Setup</i>			
1	Preparation	<ol style="list-style-type: none"><li>1. Determine an access method to select and connect the cables.</li><li>2. Determine a LAN configuration method and assign an IP address if necessary.</li></ol>	
2	Configure the iLO 2 MP LAN	Choose one of the three methods to configure the LAN for iLO 2 MP access: <ul style="list-style-type: none"><li>• DHCP with DNS</li><li>• ARP Ping</li><li>• RS-232 serial port</li></ul>	
3	Log on to the iLO 2 MP	Log in to the iLO 2 MP from a supported web browser or command line using the default user name and password.	
4	Change default user name and password	Change the default user name and password on the administrator account to your predefined selections.	
5	Set up user accounts	Set up the user accounts if you are using the local accounts feature.	
6	Set up security access	Set up the security access settings.	
<i>Advanced Setup</i>			
1	Activate Advanced Pack Features	Activate advanced features by entering a license key.	

# Setup Flowchart

Use this flowchart as a guide to assist in the iLO 2 MP setup process.

**Figure 3-22 iLO 2 MP Setup Flowchart**

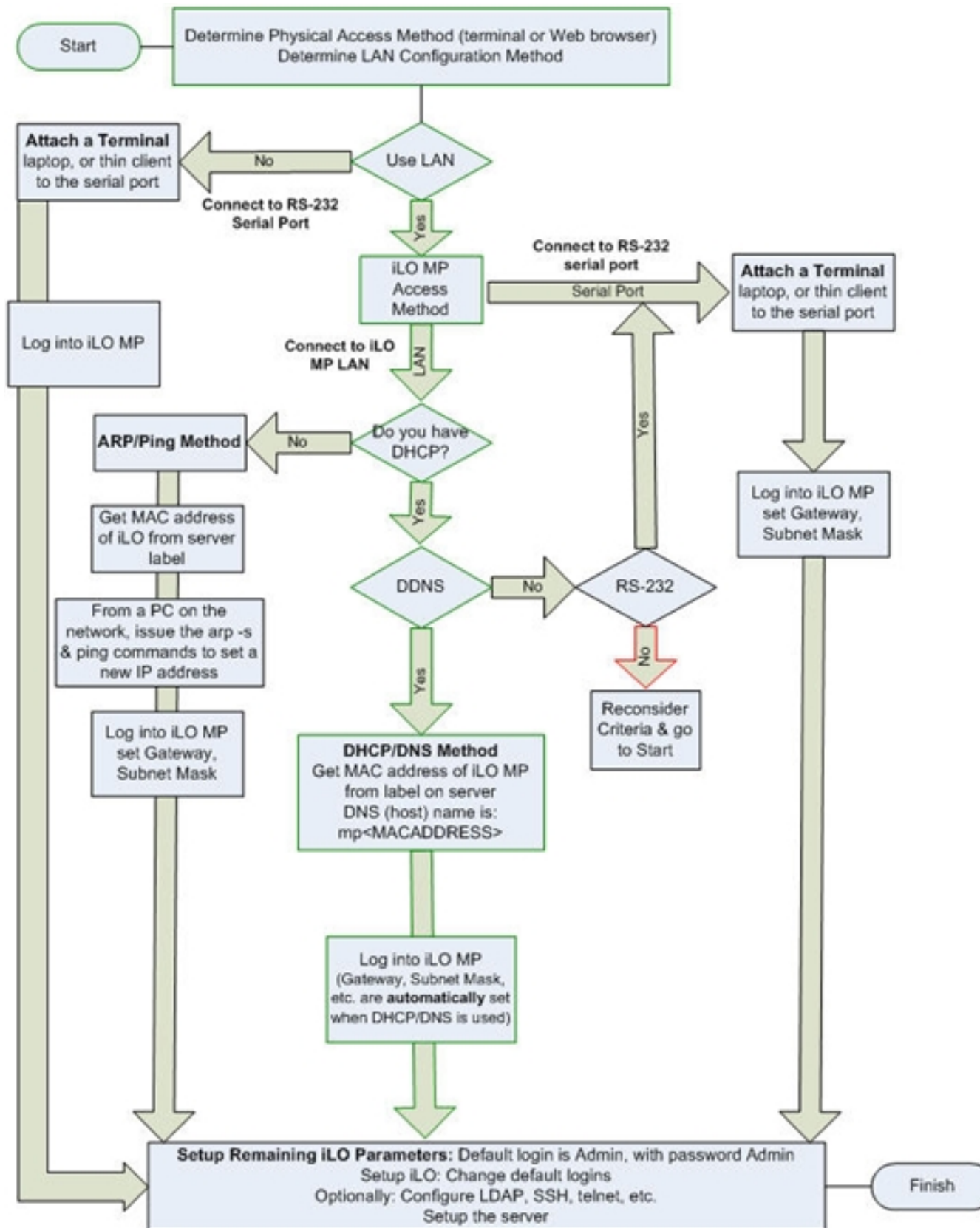

## Preparation

You must perform the following tasks before you can configure the iLO 2 MP LAN.

- Determine the physical access method to select and connect cables.
- Determine the iLO 2 MP LAN configuration method and assign an IP address if necessary.

### Determining the Physical iLO 2 MP Access Method

Before you can access the iLO 2 MP, you must first determine the correct physical connection method. The iLO 2 MP has a separate LAN port from the system LAN port. It requires a separate LAN drop, IP address, and networking information from that of the port used by the operating system. See Figure 3-21 (page 66) for rear panel console connection port identification and cable connection information.

Table 3-6 lists the appropriate connection method, required connection components, and connectors to the host console. Use Table 3-6 to determine your physical connection method.

**Table 3-6 Console Connection Matrix**

Operating System	Console Connection Method	Required Connection Components
HP-UX	Local RS-232 serial port Remote/modem port	1. RS-232 DB-9F to DB-9F modem eliminator cable 2. Console device (for example, a laptop or ASCII terminal)
	LAN port	10/100 LAN cable
Linux	Local RS-232 serial port Remote/modem port	1. RS-232 DB-9F to DB-9F modem eliminator cable 2. Console device (for example, a laptop or ASCII terminal)
	LAN port	10/100 LAN cable
OpenVMS	Local RS-232 serial port Remote/modem port	1. RS-232 DB-9F to DB-9F modem eliminator cable 2. Console device (for example, a laptop or ASCII terminal)
	LAN port	10/100 LAN cable
Windows	VGA Port (no iLO 2 MP access; EFI only)	1. Monitor (VGA) 2. Keyboard (USB) 3. Mouse (USB)
	LAN port	10/100 LAN cable

### Determining the iLO 2 MP LAN Configuration Method

To access the iLO 2 MP through the iLO 2 MP LAN, the iLO 2 MP must acquire an IP address. The way the iLO 2 MP acquires an IP address depends on whether DHCP is enabled or disabled on the server, and if DHCP and DNS services are available to the server. (See Table 3-7 for possible scenarios.)

Once you have determined the iLO 2 MP access, you must determine how you will configure the iLO 2 MP LAN to acquire an IP address using the following methods:

- DHCP/DNS
- ARP Ping
- Local RS-232 serial port
- Remote/modem port

Table 3-7 provides all the possible scenarios. Use this table to help you select the appropriate LAN configuration method to obtain an IP address.

**Table 3-7 LAN Configuration Methods**

DHCP	DNS	RS-232 Serial Port (iLO 2 MP LC command)	LAN Configuration Method
Yes	Yes	No	DHCP
Yes	Yes	Yes	DHCP, RS-232 serial port, or remote/modem port
No	No	No	ARP Ping
No	Yes	No	ARP Ping
No	Yes	Yes	ARP Ping, RS-232 serial port, or remote/modem port
Yes	No	Yes	RS-232 serial port, or remote/modem port
No	No	Yes	RS-232 serial port, remote/modem port, or ARP Ping
Yes	No	No	Cannot set up the LAN. Reconsider your criteria.

Once you have determined how you will configure the iLO 2 MP LAN in order to acquire an IP address, you must configure the iLO 2 MP LAN using the selected method.

## Configuring the iLO 2 MP LAN Using DHCP and DNS

Dynamic Host Configuration Protocol (DHCP) automatically configures all DHCP-enabled servers with IP addresses, subnet masks, and gateway addresses. All HP Integrity entry class servers with iLO 2 MP are shipped from the factory with DHCP enabled.



**TIP:** HP recommends using the DHCP and Domain Name Server (DNS) method to simplify access to the iLO 2 MP.

When you use DHCP and DNS, you can connect to the iLO 2 MP by typing the default host name in your browser rather than an IP address only if the following conditions apply:

- DHCP must be enabled (DHCP is enabled by default)
- You are using a DHCP server that provides the domain name and the primary DNS server IP address
- The primary DNS server accepts dynamic DNS (DDNS) updates
- The primary DNS server IP address has been configured through the DHCP server

To configure the iLO 2 MP using DHCP and DNS, follow these steps:

1. Obtain the factory-set host name from the iLO 2 MP Media Access Protocol (MAC) address label on the right side of the server above the rail. The default host name is 14 characters long, consisting of the letters **mp** followed by the 12 characters of the MAC address, for example: `mp0014c29c064f`. This address is assigned to the iLO 2 MP hardware. The iLO 2 MP hardware has a unique MAC address that identifies the hardware on the network.



**IMPORTANT:** Make sure you obtain the MAC address to the iLO hardware and not the MAC address to the server core LAN card.

2. Connect the LAN cable into the iLO 2 MP port on the rear of the server. [Figure 3-21 \(page 66\)](#) shows the location of the iLO 2 MP port.
3. Connect the LAN cable from the server to an active network port.
4. Apply ac power to the server (if not already done).
5. Open a browser, telnet, or SSH client and enter the iLO 2 MP IP address. The iLO 2 MP Log In window opens.

## Configuring the iLO 2 MP LAN Using ARP Ping

The Address Resolution Protocol (ARP) and Packet Internet Grouper (Ping) utility uses ARP packets to ping, or discover, a device on the local network segment. The IP address you assign to the server must use the same network segment, or subnet, as the computer assigning the address. ARP does not work across routed or switched networks.

ARP Ping operational issues include the following:

- You can use ARP Ping regardless of the status of DHCP, unless an IP address has ever been acquired using DHCP
- When ARP Ping is successful, DHCP status is disabled
- Some DHCP server options can cause the apparent issuance of ARP Ping to the iLO 2 MP which will negate the DHCP/DDNS method
- The PC and the server must be on the same physical subnet
- When a new server is first booted, DHCP is automatically available (the factory-set default), but ARP Ping does not start until three minutes after the iLO 2 MP is booted. This applies to every subsequent boot of the iLO 2 MP until an IP address is obtained by DHCP or has been assigned using the LC command, or ARP Ping succeeds

There are two ways to use the ARP Ping utility:

- Connect a PC to the network that is on the same physical subnet as the server and run the ARP Ping commands from the PC.
- Locate an existing server on the network, log into it, and run the ARP Ping commands from the server.

Table 3-8 lists the ARP Ping commands.

**Table 3-8 ARP Ping Commands**

Command	Description
arp -s	This command assigns an IP address to the iLO 2 MP MAC address. This ARP table entry maps the MAC address of the iLO 2 MP LAN interface to the static IP address designated for that interface.
ping	This command tests network connections. It verifies that the iLO 2 MP LAN port is configured with the appropriate IP address.

The following procedure explains how to use the ARP Ping utility using a PC that is connected to the network that is on the same physical subnet as the server.

To configure a static IP address using the ARP Ping utility, follow these steps:

1. Obtain the iLO 2 MP MAC address. To set the IP address using ARP, you must know the MAC address of the iLO 2 MP LAN. You can find the MAC address of the iLO 2 MP LAN on the label located on the server front panel.



**IMPORTANT:** Make sure you obtain the MAC address of the iLO 2 MP LAN and not the MAC address of the server core LAN.

2. Verify that an active LAN cable on the local subnet is connected to the iLO 2 MP LAN port on the server.
3. Access a PC on the same physical subnet as the server.
4. Open a DOS window on the PC.
5. At the DOS prompt, enter **arp -s** to assign the IP address to the iLO MAC address.

**arp -s** <IP address you assign to the iLO MAC address> <iLO MAC address>

For example:

**arp -s 192.0.2.1 00-00-0c-07-ac-00**



6. At the DOS prompt, enter **ping** followed by the IP address to verify that the iLO 2 MP LAN port is configured with the appropriate IP address. The destination address is the IP address that is mapped to the iLO MAC address. Perform this task from the PC that has the ARP table entry.

**ping** <IP address you assigned to the iLO MAC address>

For example:

**ping 192.0.2.1**

7. Connect to the iLO 2 MP LAN using this IP address.
8. Use web or telnet access to connect to the iLO 2 MP from a host on the local subnet and finish setting up the LAN parameters (gateway and subnet).

## Configuring the iLO 2 MP LAN Using the RS-232 Serial Port

The following procedure shows how to configure the iLO 2 MP LAN using the RS-232 serial port.



---

**IMPORTANT:** Do not configure duplicate IP addresses on different servers within the same network. Duplicate server IP addresses conflict and the servers cannot connect to the network.

---

The **LC** command enables you to configure an IP address, host name, subnet mask, and gateway address.



---

**IMPORTANT:** Ensure you have a console connection through the RS-232 serial port or a network connection through the LAN to access the iLO 2 MP and use the **LC** command.

---

To assign a static IP address using the **LC** command, follow these steps:

1. Ensure the emulation software device is properly configured. The terminal emulation device runs software that interfaces with the server. The software emulates console output as it would appear on an ASCII terminal screen and displays it on a console device screen.
2. To ensure the emulation software is correctly configured, verify the following:
  - a. Verify that the communication settings are configured as follows:
    - 8/none (parity)
    - 9600 baud
    - None (receive)
    - None (transmit)
  - b. Verify that the terminal type is configured appropriately. Supported terminal types are as follows:
    - hpterm
    - vt100
    - vt100+
    - vt-utf8



---

**IMPORTANT:** Do not use hpterm and vt100 terminal types at the same time.

---

There are many different emulation software applications. Consult the help section of your emulation software application for instructions on how to configure the software options.

3. Use Table 3-6 to determine the required connection components and the ports used to connect the server to the console device.

4. Connect the cables.
  - a. Connect the DB-9 end of the RS-232 serial port female-to-female cable to the console RS-232 serial port.
  - b. Connect the other end of the DB-9 female-to-female cable to the console device.
5. Start the emulation software on the console device.
6. Log in to the iLO 2 MP. See “Logging In to the iLO 2 MP” (page 74).
7. At the **MP Main Menu**, enter **CM** and press **Enter** to select command mode.
8. At the command mode prompt, enter **LS** and press **Enter**. The screen displays the default LAN configuration values. Write down the default values or log the information to a file for future troubleshooting.
9. Use the LC command to disable DHCP.
  - a. From the LC command menu, enter **D** and press **Enter**.
  - b. Follow the instructions on the screen to change the DHCP status from Enabled to Disabled.
  - c. Enter **XD -R** to reset the iLO 2 MP.
10. Use the LC command to enter information for the IP address, host, subnet mask, gateway parameters, and so on.
11. Enter **XD -R** to reset the iLO 2 MP.
12. After the iLO 2 MP resets, log in to the iLO 2 MP again and enter **CM** at the MP> prompt.
13. Enter **LS** to confirm that DHCP is disabled and display a list of updated LAN configuration settings.

## Logging In to the iLO 2 MP

To log in to the iLO 2 MP, follow these steps:

1. Access the iLO 2 MP using the LAN, RS-232 serial port, telnet, SSH, or web method. The iLO 2 MP login prompt appears.
2. Log in using the default the iLO 2 MP user name and password (**Admin/Admin**). The **MP Main Menu** screen appears.



**TIP:** For security reasons, HP strongly recommends that you modify the default settings during the initial login session. See “Modifying User Accounts and Default Password” (page 75).

---

The **MP Main Menu** screen displays the following menu options:

```
MP MAIN MENU:
  CO: Console
  VFP: Virtual Front Panel
  CM: Command Menu
  CL: Console Logs
  SL: Show Event Logs
  HE: Main Menu Help
  X: Exit Connection
```

This example shows the **MP Main Menu** accessed through the local serial port. The list of commands displayed on the screen can be different depending on the method of access to the iLO 2 MP.

When logging in using the local or remote RS-232 serial ports, the login prompt may not display if another user is logged in through these ports. Use **Ctrl-B** to access the **MP Main Menu** and the iLO 2 MP MP> prompt.

## Additional Setup

This section provides additional information to help you set up the iLO 2 MP.

### Modifying User Accounts and Default Password

The iLO 2 MP comes preconfigured with default factory settings, including a default user account and password. The two default user accounts at initial login are as follows:

- All Rights (Administrator) level user: login = **Admin** password = **Admin**
- Console Rights (Operator) level user: login = **Oper** password = **Oper**



---

**NOTE:** User account and password are case sensitive.

---



---

**IMPORTANT:** For security reasons, HP strongly recommends that you modify the default settings during the initial login session.

---

Make the following changes using any of the iLO 2 MP user interfaces.

To modify default account configuration settings, follow these steps:

1. Log in as the administrator. You must log in as the administrator in order to modify default user configuration settings.
2. To modify default passwords, follow these steps:
  - a. Access the **MP Main Menu**.
  - b. Enter **CM** at the MP> prompt.
  - c. Enter **UC** at the MP : CM> prompt and follow the prompts to modify default passwords.
3. To set up user accounts, follow these steps:
  - a. Access the **MP Main Menu**.
  - b. Enter **CM** at the MP> prompt.
  - c. Enter **UC** at the MP : CM> prompt and follow the prompts to modify user accounts.

### Setting Up Security

For greater security and reliability, HP recommends that iLO 2 MP management traffic be on a separate dedicated management network and that only administrators be granted access to that network. This not only improves performance by reducing traffic load across the main network, it also acts as the first line of defense against security attacks. A separate network enables administrators to physically control which workstations are connected to the network.

HP also strongly recommends that you modify the default settings during the initial login session and determine the security access required and what user accounts and privileges are needed. Create local accounts or use directory services to control user access. See “Modifying User Accounts and Default Password” (page 75).



**CAUTION:** When DHCP is enabled, the system is vulnerable to security risks because anyone can access the iLO 2 MP until you change the default user name and password.

HP strongly recommends you assign user groups and rights before proceeding.

---

Determine the security access required and user accounts and privileges needed. The iLO 2 MP provides options to control user access. Select one of the following options to prevent unauthorized access to the iLO 2 MP:

- Change the default user name and password. See “Modifying User Accounts and Default Password” (page 75).
- Create local accounts. You can store up to 19 user names and passwords to manage iLO 2 MP access. This is ideal for small environments such as labs and small-to-medium sized businesses.
- Use directory services. Use the corporate directory to manage iLO 2 MP user access. This is ideal for environments with a large number of frequently changing users. If you plan to use directory services, HP recommends leaving at least one local account enabled as an alternate method of access.

## Accessing the Host Console

This section describes the different ways to access the host console of the rx2660 server.

### Accessing the Host Console With the TUI - CO Command

This section describes the steps to access the host console using the text user interface (TUI).

To access the host console through the iLO 2 MP, follow these steps:

1. Log in using your user account name and password at the login page.
2. At the iLO 2 MP login MP> prompt, enter the **CO** command to switch the console terminal from the **MP Main Menu** to mirrored/redirected console mode. All mirrored data displays.
3. To return to the iLO 2 MP command interface, enter **Ctrl-B** or **Esc** and **+** and press **Enter**.

### Interacting with the iLO 2 MP Using the Web GUI

Web browser access is an embedded feature of the iLO 2 MP.

The iLO 2 MP has a separate LAN port from the system LAN port. It requires a separate LAN drop, IP address, and networking information from that of the port used by the operating system.



**IMPORTANT:** Make sure you use the MAC address to the iLO 2 MP LAN, and not the MAC address to the server core LAN.

---

Before starting this procedure, you must have the following information:

- IP address for the iLO 2 MP LAN
- Host name (used when messages are logged or printed)

To interact with the iLO 2 MP through the web GUI, follow these steps:

1. Open a web browser and enter the host name or the IP address for the iLO 2 MP.
2. Log in using your user account name and password at the web login page. (Figure 3-23).

**Figure 3-23 Web Login Page**

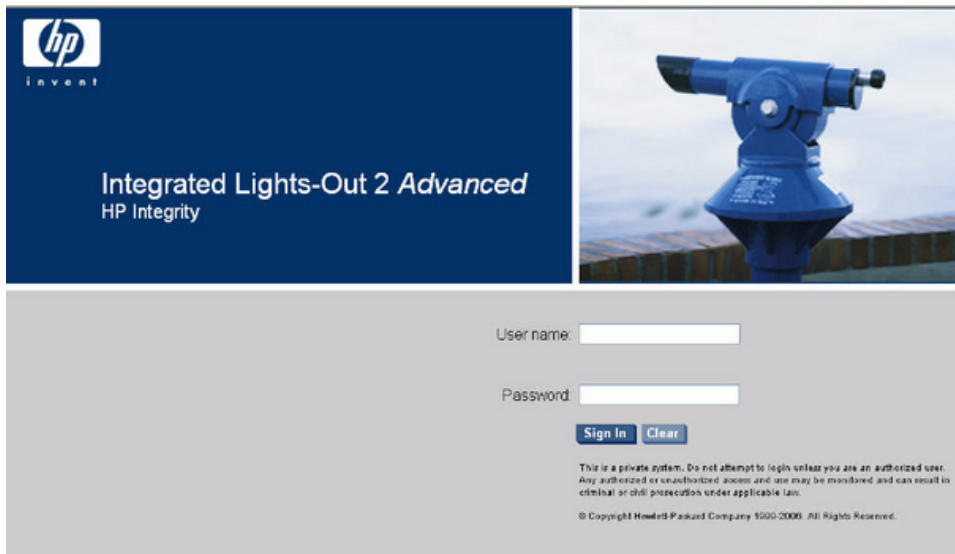

3. Click **Sign In**. The Status Summary page (Figure 3-24) appears after login.

**Figure 3-24 Status Summary Page**

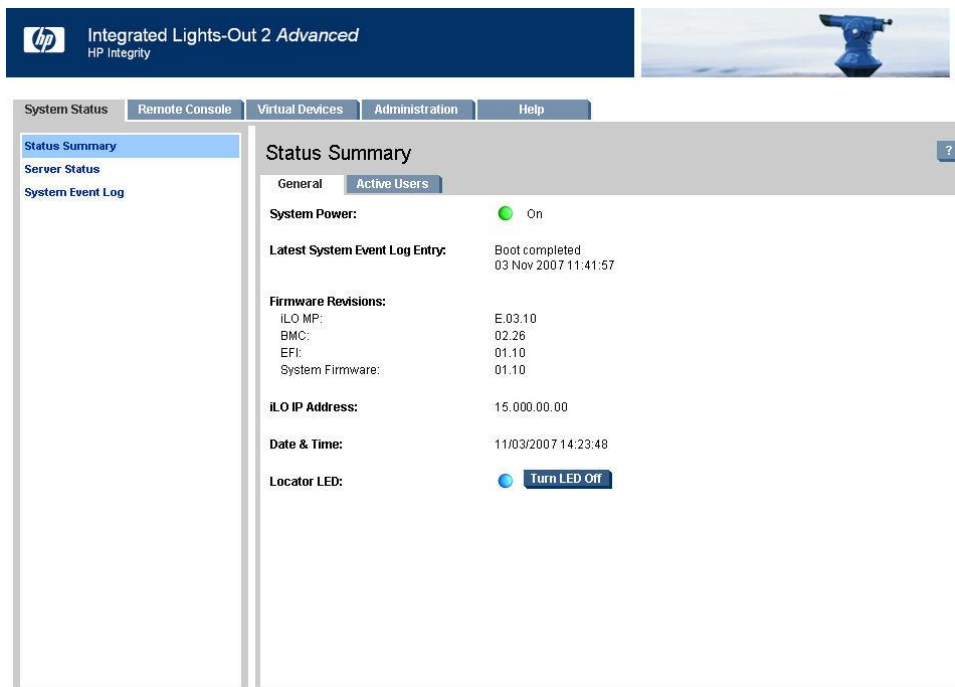

4. Select the web interface functions by clicking the **Function** tabs at the top of the page. Each function lists options in the **Navigation Bar** on the left side of the page.
5. Click an option link to display data in the display screen.
6. Click **Refresh** to update the display.

The iLO 2 MP web interface has a robust help system. To launch iLO 2 MP help, click the **Help** tab in the display screen or click the question mark key (?) at the top right corner of each page to display help about that page.

## Accessing the Graphic Console Using VGA

VGA is a method you can use to access the graphic console.



**NOTE:** You cannot access the iLO 2 MP using VGA.

This method requires the following elements:

- Monitor (VGA connector)
- Keyboard (USB connector)
- Mouse (USB connector)

The graphic console output displays on the monitor screen.



**IMPORTANT:** The server console output does not display on the console device screen until the server boots to the EFI Shell. Start a console session using the RS-232 serial port method to view console output prior to booting to the EFI Shell or to access the iLO 2 MP. See “Configuring the iLO 2 MP LAN Using the RS-232 Serial Port” (page 73).

To access the graphic console with VGA, follow these steps:

1. Connect the monitor, keyboard, and mouse cables.
  - a. Connect the monitor VGA cable to the appropriate VGA port on your server.
  - b. Connect the keyboard USB cable to the appropriate USB port on your server.
  - c. Connect the mouse USB cable to the appropriate USB port on your server.
2. Power on the server. The EFI Shell prompt appears.

## Powering On and Powering Off the Server

This section provides information and procedures for powering on and powering off the server.

### Power States

The server has three power states:

- Standby power
- Full power
- Off

Table 3-9 lists the server power states.

**Table 3-9 Power States**

Power States	Power Cable Plugged Into Receptacle?	Power Activated through the iLO 2 MP <sup>PC</sup> Command; or Front Panel Power Button Activated?	Standby dc Voltage Applied?	dc Voltage Applied?
Standby power	Yes	No	Yes	No
Full power	Yes	Yes	Yes	Yes
Off	No	No	No	No



**NOTE:** If the power restore feature is set to **Always On** through the iLO 2 MP <sup>PR</sup> command, the server automatically powers on to the full power state when the power cord is plugged in to the server.

### Powering On the Server

Power on the server to full power using the following methods if the server is in the standby power state:

- iLO 2 MP <sup>PC</sup> command
- Power button

## Powering On the Server Using the iLO 2 MP

---



**NOTE:** If the power restore feature is set to **Always On** through the iLO 2 MP **PR** command, the server automatically powers on to the full power state when the power cord is plugged in to the server.

---

To power on the server using the iLO 2 MP, follow these steps:

1. Plug all power cables into the receptacles on the rear panel of the server.
2. Initiate a console session, and access the **MP Main Menu**.
3. Enter **CM** to enable command mode.
4. Enter **PC** to use the remote power control command.
5. Enter **ON** to power on the server, and enter **YES** when prompted to confirm the action.
6. Start the operating system. For more information, see the operating system documentation.

## Powering On the Server Manually

---



**NOTE:** If the power restore feature is set to **Always On** through the iLO 2 MP **PR** command, the server automatically powers on to the full power state when the power cord is plugged in to the server.

---

To manually power on the server, follow these steps:

1. Plug all power cables into the receptacles on the rear panel of the server.
2. Press the power button to start the server.
3. Start the operating system. For more information, see the operating system documentation.)

## Powering Off the Server

Power off the server using the following methods if the server is in the standby or full power state:

- iLO 2 MP **PC** command
- Power button

## Powering Off the Server Using the iLO 2 MP

To power off the server using the iLO 2 MP, follow these steps:

1. Gracefully shut down the operating system. See the operating system documentation for more information.
  2. Initiate a console session, and access the **MP Main Menu**.
  3. Enter **CM** to enable command mode.
  4. Enter **PC** to use the remote power control command.
  5. Enter **OFF** to power off the server, and enter **YES** when prompted to confirm the action.
- 



**CAUTION:** The main dc voltage is now removed from the system; however, ac voltage for standby power is still present in the server.

---

6. Unplug all power cables from the receptacles on the rear panel of the server.

## Powering Off the Server Manually

To manually power off the server, follow these steps:

1. Gracefully shut down the operating system. For more information, see the operating system documentation.

2. Press the power button to power off the server.



**CAUTION:** The main dc voltage is now removed from the system; however, ac voltage for standby power is still present in the server.

---

3. Unplug all power cables from the receptacles on the rear panel of the server.

## Verifying Installed Components In the Server

This section describes how to verify that the components installed in the server are recognized by the server.

Use the following procedure to verify that the components you have installed into the rx2660 server are recognized by the server.



**NOTE:** The processor cache information in the Processor Module Information below shows the L3 Cache Size per logical CPU. Since there are two logical CPUs per processor (dual-core), a reading of 6 MB for the L3 cache means that the cache size is 12 MB.

---

1. Select **EFI Boot Option** from the **EFI Boot Manager** menu.
2. Wait for the `EFI Shell` prompt to appear.



3. Enter **info all** from the EFI Shell prompt. The following displays:

```
Shell>
- - - - - Live Console - - - - -
info all

SYSTEM INFORMATION

Date/Time: Mar 6, 2007 13:00:10 (20:07:03:06:13:00:10)
Manufacturer: hp
Product Name: server rx2660
Product Number: AB419A
Serial Number: US64293295
UUID: B6DDD02D-774F-11DB-8759-5250AF09A183
System Bus Frequency: 266 MHz

PROCESSOR MODULE INFORMATION
```

CPU Module	# of Logical CPUs	Speed	L3 Cache Size	L4 Cache Size	Family/Model (hex.)	Rev	Processor State
0	2	1.6 GHz	12 MB	None	20/00	C1	Active

CPU threads are turned off.

MEMORY INFORMATION

---- DIMM A ----			---- DIMM B ----	
DIMM	Current		DIMM	Current
0	1024MB	Active	1024MB	Active
1	1024MB	Active	1024MB	Active
2	512MB	Active	512MB	Active
3	512MB	Active	512MB	Active

Active Memory : 6144 MB  
 Installed Memory : 6144 MB

I/O INFORMATION

BOOTABLE DEVICES

Order	Media Type	Path
1	CDROM	Acpi (HWP0002, PNP0A03, 0) / Pci (2   1) / Usb (0, 0) / CDROM (Entry0)
2	HARDDRIVE	Acpi (HWP0002, PNP0A03, 200) / Pci (1   0) / Sas (Addr500000E011B1E0)
3	HARDDRIVE	Acpi (HWP0002, PNP0A03, 200) / Pci (1   0) / Sas (Addr500000E011B1E0)
4	HARDDRIVE	Acpi (HWP0002, PNP0A03, 200) / Pci (1   0) / Sas (Addr5000C500003A05)
5	HARDDRIVE	Acpi (HWP0002, PNP0A03, 200) / Pci (1   0) / Sas (Addr5000C500003A05)
6	HARDDRIVE	Acpi (HWP0002, PNP0A03, 200) / Pci (1   0) / Sas (Addr500000E0119F9C)
7	HARDDRIVE	Acpi (HWP0002, PNP0A03, 200) / Pci (1   0) / Sas (Addr500000E0119F9C)

Seg #	Bus #	Dev #	Fnc #	Vendor ID	Device ID	Slot #	Path
00	00	01	00	0x103C	0x1303	XX	Acpi (HWP0002, PNP0A03, 0) / Pci (1   0)
00	00	01	01	0x103C	0x1302	XX	Acpi (HWP0002, PNP0A03, 0) / Pci (1   1)
00	00	01	02	0x103C	0x1048	XX	Acpi (HWP0002, PNP0A03, 0) / Pci (1   2)
00	00	02	00	0x1033	0x0035	XX	Acpi (HWP0002, PNP0A03, 0) / Pci (2   0)
00	00	02	01	0x1033	0x0035	XX	Acpi (HWP0002, PNP0A03, 0) / Pci (2   1)
00	00	02	02	0x1033	0x00E0	XX	Acpi (HWP0002, PNP0A03, 0) / Pci (2   2)
00	00	03	00	0x1002	0x515E	XX	Acpi (HWP0002, PNP0A03, 0) / Pci (3   0)
00	01	01	00	0x1000	0x0054	XX	Acpi (HWP0002, PNP0A03, 200) / Pci (1   0)
00	01	02	00	0x14E4	0x1648	XX	Acpi (HWP0002, PNP0A03, 200) / Pci (2   0)
00	01	02	01	0x14E4	0x1648	XX	Acpi (HWP0002, PNP0A03, 200) / Pci (2   1)
00	02	01	00	0x1133	0xB921	03	Acpi (HWP0002, PNP0A03, 300) / Pci (1   0)
00	03	01	00	0x13F6	0x0111	02	Acpi (HWP0002, PNP0A03, 600) / Pci (1   0)
00	04	01	00	0x8086	0x1079	01	Acpi (HWP0002, PNP0A03, 700) / Pci (1   0)
00	04	01	01	0x8086	0x1079	01	Acpi (HWP0002, PNP0A03, 700) / Pci (1   1)

Fast initialization: Disabled

System Wake-On-LAN: Enabled

BOOT INFORMATION

Monarch CPU:

Current	Preferred	
Monarch CPU	Monarch CPU	
Module/Logical	Module/Logical	Warnings
-----	-----	-----
0/0	0/0	

AutoBoot: OFF - Timeout is disabled

Boottest:

BOOTTEST Settings Default Variable

OS is not speedy boot aware.

Selftest	Setting
-----	-----
early_cpu	Run this test
late_cpu	Run this test
platform	Run this test
chipset	Run this test
io_hw	Run this test
mem_init	Run this test
mem_test	Run this test

LAN Address Information:

LAN Address	Path
-----	-----
*Mac(0017A4990DFB)	Acpi(HWP0002,PNP0A03,200)/Pci(2 0)/Mac(0017A4990DFB)
Mac(0017A4990DFA)	Acpi(HWP0002,PNP0A03,200)/Pci(2 1)/Mac(0017A4990DFA)
Mac(001560045FE0)	Acpi(HWP0002,PNP0A03,700)/Pci(1 0)/Mac(001560045FE0)
Mac(001560045FE1)	Acpi(HWP0002,PNP0A03,700)/Pci(1 1)/Mac(001560045FE1)

FIRMWARE INFORMATION

\*System Firmware A Revision: 1.05 [4645]

PAL\_A: 7.31/7.46  
PAL\_B: 8.30  
EFI Spec: 1.10  
EFI Intel Drop: 14.62  
EFI Build: 5.65  
SAL Spec: 3.20  
SAL\_A: 2.00  
SAL\_B: 1.05  
POSSE: 0.21  
ACPI: 7.00  
SMBIOS: 2.3.2a

System Firmware B Revision: 1.04 [4645]

BMC Revision: 5.06

IPMI: 1.00

Management Processor Revision: F.01.58

Updatable EFI Drivers:

Floating-Point Software Assistance Handler:	00000118
Broadcom Gigabit Ethernet Driver:	00090404
SCSI Bus Driver:	00000021
SCSI Tape Driver:	00000020
Usb Ohci Driver:	00000034
USB Bus Driver:	00000014
USB Bot Mass Storage Driver:	00000014
Generic USB Mass Storage Driver:	00000015

\* Indicates active system firmware image

WARNING AND STOP BOOT INFORMATION

## CHIP REVISION INFORMATION

Chip Type	Logical ID	Device ID	Chip Revision
Memory Controller	0	4032	0020
Root Bridge	0	4030	0020
Host Bridge	0000	122e	0032
Host Bridge	0002	122e	0032
Host Bridge	0003	12ee	0011
Host Bridge	0006	12ee	0011
Host Bridge	0007	12ee	0011
Other Bridge	0	0	0030
Other Bridge	0	0	5003
Baseboard MC	0	0	0506

## SYSTEM SECURITY CONFIGURATION

```
Trusted Boot:      Not Supported
TPM:               Activated
TPM Next Boot Status: Activated
TPM Vendor ID:    0x15D1
TPM Product ID:   0x0006
TPM TCG Spec Version: 1.1.0.0
```

Shell>

## Installation Troubleshooting

This section provides basic server troubleshooting information. It is designed to help you diagnose common issues that can occur during server installation, and addresses the following topics:

- “Troubleshooting Methodology” (page 83)
- “Server Does Not Power On” (page 84)
- “Troubleshooting Using the Server Power Button” (page 84)
- “EFI Menu is Not Available” (page 85)
- “Operating System Does Not Boot” (page 85)
- “Operating System Boots with Problems” (page 85)
- “Intermittent Server Problems” (page 85)
- “DVD Problems” (page 85)
- “Hard Drive Problems” (page 86)
- “Console Problems” (page 86)
- “Downloading and Installing the Latest Version of the Firmware” (page 86)

## Troubleshooting Methodology

The server was tested prior to shipping. Failures encountered during installation can be due to damage that occurred in transit. Re-seating connectors can clear problems that result from rough handling. If you are installing components or assemblies, compatibility problems or incorrect installations can be the cause of the problems. If you are installing components or assemblies, check that items are correctly installed and that all connectors are fully engaged. If the unit does not power on, check the power source before proceeding.

If a problem is encountered during initial operation, remove any add-in or optional components and retest the server before continuing. Verify basic server operation before installing additional cards and configuring software and hardware for the server requirements.

Troubleshooting is based on observation of server status indications and error messages, and by checking system event logs. You can observe the LED indicators on the front and rear of the server. Error messages are displayed on local and remote consoles. System history (console, event, and history logs) is available through the iLO 2 MP, and is accessed through the console. Additional information about troubleshooting is available on the CD provided with the server.

Offline troubleshooting programs are available on the resource CD that is shipped with the server. To troubleshoot the server, you must be familiar with the Offline Diagnostics Environment (ODE) which runs in the Extensible Firmware Interface (EFI). Descriptions and user information about offline troubleshooting tools are available at <http://www.docs.hp.com>. The offline tools are available for downloading at <http://www.software.hp.com>.

## Troubleshooting Using the Server Power Button

The server power button on the front panel operates differently depending on how long the button is held in, and on what the system is doing when the button is pressed. You must be aware of its uses to properly troubleshoot the system.

Table 3-10 describes what happens when the server is at EFI, and you press the power button.

**Table 3-10 Server Power Button Functions When Server is On and at EFI**

Action	Reaction
1-3 seconds	System power turns off immediately (hard power off)
5 seconds or longer	System power turns off immediately (hard power off)

Table 3-11 describes what happens when the server is on with the operating system running, and you press the power button.

**Table 3-11 Server Power Button Functions When Server is On and OS is Running**

Action	Reaction
1-3 seconds	System power turns off (software controlled power off)
5 seconds or longer	System power turns off immediately (hard power off)

If the server is off, and power is not connected to server power supplies, pressing the power button has no effect.

If the server is off, and power is connected to server power supplies, the front panel power LED blinks at a 1 Hz rate. In this state, standby power is available to server circuits, but main power is off. Table 3-12 describes what happens when the server is off, and you press the power button.

**Table 3-12 Server Power Button Functions When Server is Off**

Action	Reaction
1-3 seconds	System power turns on

## Server Does Not Power On

The server power button on the front panel operates differently depending on how long the button is held, and on what the system is doing when the button is pressed. You must be aware of its uses to properly troubleshoot the system.



**NOTE:** If the server is off, and power is not connected to server power supplies, pressing the power button has no effect.

Power problems during installation are usually related to the installation process. If the server does not power on, check the LED indicators on the power supply rear panels and follow these steps.

- If the ac power LED on the power supply on the rear panel of the server is lit, power is available to the server.
- If the ac power LED is not lit, the server is either in standby power mode, or there is a problem. Re-seat the power supply. If the problem persists, remove and re-seat the board

within the server. If the problem persists, replace the power supply or the power supply interface board.

- If the console shows that the server is powered on, but server LEDs indicate that power is off, remove and re-seat connectors on the LED status board. If the problem persists, replace the LED status board. If the console shows that the server is not powered on (server is off), remove and re-seat connectors on the system board. If the problem persists, replace the power supply interface board, or the system board.

## EFI Menu is Not Available

If you cannot access the EFI from either the main disk partition or the CD, use the following tools to help solve the problem:

- Front panel LEDs
- iLO 2 MP
  - Console messages
  - System event logs (SEL)

## Operating System Does Not Boot

If the operating system does not boot, but you are able to reach the EFI from either the main disk partition or the CD, use the following tools to help solve the problem:

- Using the EFI Shell, check the system logs and analyze any error messages.
- Offline Diagnostic Environment (ODE)

## Operating System Boots with Problems

If the operating system is running and you are experiencing problems, use the following tools to help solve the problem:

- LEDs
- Error Messages and event logs

## Intermittent Server Problems

You can usually trace intermittent problems that occur during installation to power source problems, a loose connector, or some other hardware problem. If you are experiencing intermittent problems, follow these steps:

1. Check iLO 2 MP logs and analyze the problem. Determine if there is more than one symptom and if the problem is random.
2. Verify that the ac power source is stable.
3. Re-seat all rear panel connectors.
4. Re-seat all hot-swappable fans and power supplies.
5. Re-seat all main memory DIMMs.
6. Re-seat all cable harnesses and board connectors.

## DVD Problems

DVD problems that occur during installation are usually related to faulty connections. If you are experiencing DVD problems, follow these steps:

1. Remove and reinsert the disk.
2. Replace the disk.
3. Remove and reinstall the DVD drive. Check that connectors are fully engaged.
4. Replace the DVD drive.

## Hard Drive Problems

Hard drive problems that occur during installation are usually due to rough handling. The drive may not be correctly seated or may have been damaged in transit. If you are experiencing hard drive problems, follow these steps:

1. Remove and reinsert the faulty hard drive.
2. Swap the hard drive with one from another slot or with a known good spare.
3. Remove and reinstall the hard drive backplane. Check that connectors are fully engaged.
4. Replace the hard drive backplane.

## Console Problems

Console problems during installations can be caused by faulty interconnections. If you are experiencing monitor, keyboard, or mouse problems, follow these steps:

1. Check the monitor controls. Adjust contrast and brightness as required.
2. Inspect all power and interconnecting cables. Check that all console connectors are fully engaged.
3. Check that all iLO 2 MP board connectors are fully engaged.
4. Exercise the appropriate self-test features of the console software.

## Downloading and Installing the Latest Version of the Firmware

HP makes every effort to provide you with the most current version of firmware. However, there can be instances when this is not the case.

To ensure you have the latest version of the firmware running on the server, download the latest version of the firmware from the web, and create a CD to install the firmware on the server.

### Downloading the Latest Version of the Firmware

To download the latest version of the firmware from the web, follow these steps:

1. Go to: <http://www.hp.com/go/bizsupport>
2. Select **download drivers and software**.
3. Select **Itanium-based servers** from the Server category.
4. Select your product from the servers listed.
5. Select your operating system.
6. Select the firmware package you want to download.
7. Download the firmware package, and follow the instructions for updating the firmware included in the release notes.

### Installing the Latest Version of the Firmware on the Server

To install the latest version of the firmware on the server, follow these steps:

1. Initiate a server console session.
2. Insert the CD with the copy of the latest version of the firmware.
3. Using the **EFI Boot Manager** menu, boot to the drive that contains the CD with the updated firmware.
4. Follow the instructions to update the firmware.

---

# 4 Booting and Shutting Down the Operating System

This chapter covers procedures for booting and shutting down an operating system on the HP Integrity rx2660 server. The following operating systems are supported on HP Integrity servers: HP-UX 11i Version 3 (11.31), HP OpenVMS, Microsoft Windows Server 2003, Red Hat Enterprise Linux, and SuSE Linux Enterprise Server.

This chapter addresses the following topics:

- “Operating Systems Supported on HP Integrity Servers” (page 87).
- “Configuring System Boot Options” (page 87).
- “Booting and Shutting Down HP-UX” (page 88).
- “Booting and Shutting Down HP OpenVMS” (page 93).
- “Booting and Shutting Down Microsoft Windows” (page 97).
- “Booting and Shutting Down Linux” (page 101).

## Operating Systems Supported on HP Integrity Servers

HP supports the following operating systems on entry-class HP Integrity servers.

- **HP-UX 11i Version 3 (11.31)**  
For details see “Booting and Shutting Down HP-UX” (page 88).
- **HP OpenVMS I64**  
For details see “Booting and Shutting Down HP OpenVMS” (page 93).
- **Microsoft Windows Server 2003**  
For details see “Booting and Shutting Down Microsoft Windows” (page 97).
- **Red Hat Enterprise Linux 5**  
For details see “Booting and Shutting Down Linux” (page 101).
- **SuSE Linux Enterprise Server 10**  
For details see “Booting and Shutting Down Linux” (page 101).

## Configuring System Boot Options

This section discusses the configurable server boot options on entry-class HP Integrity servers, including the boot options list and the autoboot setting for the server.

- **Boot Options List** The boot options list is a list of loadable items available for you to choose from the **EFI Boot Manager** menu. Ordinarily the boot options list includes the EFI Shell and one or more operating system loaders.

The following example includes boot options for HP OpenVMS, Microsoft Windows, HP-UX, and the EFI Shell. The final item in the **EFI Boot Manager** menu, the **Boot Configuration Menu**, is not a boot option. The **Boot Configuration Menu** allows server configuration through a maintenance menu.

```
EFI Boot Manager ver 1.10 [14.61] Please select a boot option
```

```
HP OpenVMS 8.2-1
EFI Shell [Built-in]
Windows Server 2003, Enterprise
HP-UX Primary Boot: 4/0/1/1/0.2.0
Boot Option Maintenance Menu
```

```
Use ^ and v to change option(s). Use Enter to select an option
```



---

**NOTE:** In some versions of EFI, the **Boot Configuration Menu** is listed as the **Boot Option Maintenance Menu**.

---

To manage the boot options list for each server, use the EFI Shell, the EFI **Boot Configuration Menu**, or operating system utilities.

At the EFI Shell, the `bcfg` command supports listing and managing the boot options list for all operating systems, except Microsoft Windows. On HP Integrity servers with Windows installed, the `\MSUtil\nvrboot.efi` utility is provided for managing Windows boot options from the EFI Shell. For HP Integrity servers with OpenVMS installed, the `\efi\vms\vms_bcfg.efi` and `\efi\vms\vms_show` utilities are provided for managing OpenVMS boot options.

The EFI **Boot Configuration Menu** provides the **Add a Boot Option**, **Delete Boot Option(s)**, and **Change Boot Order** menu items (use this method if you must add an EFI Shell entry to the boot options list).

Operating system utilities for managing the boot options list include the HP-UX `setboot` command, and the HP OpenVMS `@SYS$MANAGER:BOOT_OPTIONS.COM` command.

For details, see the following sections:

- Setting HP-UX boot options (see “Adding HP-UX to the Boot Options List” (page 89))
- Setting OpenVMS boot options (see “Adding OpenVMS to the Boot Options List” (page 93))
- Setting Windows boot options (see “Adding Microsoft Windows to the Boot Options List” (page 97))
- Setting Linux boot options (see “Adding Linux to the Boot Options List” (page 101))
- **Autoboot Setting** The `autoboot` setting determines, at startup, whether a server automatically loads the first item in the boot options list, or remains at the **EFI Boot Manager** menu. When `autoboot` is enabled, EFI loads the first item in the boot options list after a designated timeout period.

Configure the `autoboot` setting for an HP Integrity server using either the `autoboot` EFI Shell command, or the **Set Auto Boot TimeOut** menu item from the **EFI Boot Configuration Menu**.

For example, from the EFI Shell to disable `autoboot` issue the `autoboot off` command. To enable `autoboot` with the default timeout value issue the `autoboot on` command. To enable `autoboot` with a timeout of 60 seconds issue the `autoboot time 60` command.

Set `autoboot` from HP-UX using the `setboot` command. Enable `autoboot` from HP-UX using the `setboot -b on` command. Disable `autoboot` using the `setboot -b off` command.

## Booting and Shutting Down HP-UX

This section covers booting and shutting down HP-UX on entry-class HP Integrity servers.

- To add an HP-UX entry to the boot options list, see “Adding HP-UX to the Boot Options List”.
- To boot HP-UX, use the following procedures:
  - “Standard HP-UX Booting” (page 89) describes the standard ways to boot HP-UX. Typically this results in booting HP-UX in multi-user mode.
  - “Booting HP-UX in Single-User Mode” (page 91) describes how to boot HP-UX in single-user mode.
  - “Booting HP-UX in LVM Maintenance Mode” (page 92) describes how to boot HP-UX in Logical Volume Management (LVM) maintenance mode.
- To shut down the HP-UX operating system, see “Shutting Down HP-UX” (page 93).



## Adding HP-UX to the Boot Options List

This section describes how to add an HP-UX entry to the server boot options list.

You can add the `\EFI\HPUX\HPUX.EFI` loader to the boot options list from the EFI Shell or EFI Boot Configuration menu (or in some versions of EFI, the Boot Option Maintenance Menu).



**NOTE:** On HP Integrity servers, the operating system installer automatically adds an entry to the boot options list.

This procedure adds an HP-UX item to the boot options list from the EFI Shell.

To add an HP-UX boot option when logged in to HP-UX, use the `setboot` command. For details see the `setboot(1M)` manpage.

1. Access the EFI Shell environment.

Log in to the iLO 2 MP and enter `CO` to access the server console.

When accessing the console, confirm that you are at the EFI Boot Manager menu (the main EFI menu). If you are at another EFI menu, choose the **Exit** option from the submenus until you return to the screen with the `EFI Boot Manager` heading.

From the **EFI Boot Manager menu**, choose the **EFI Shell** menu option to access the EFI Shell environment.

2. Access the EFI System Partition (`fsX`: where `X` is the file system number) for the device from which you want to boot HP-UX.

For example, enter `fs2`: to access the EFI System Partition for the bootable file system number 2. The EFI Shell prompt changes to reflect the file system currently accessed.

The full path for the HP-UX loader is `\EFI\HPUX\HPUX.EFI` and it should be on the device you are accessing.

3. At the EFI Shell environment, use the `bcfg` command to manage the boot options list.

The `bcfg` command includes the following options for managing the boot options list:

- `bcfg boot dump`: Display all items in the boot options list for the server.
- `bcfg boot rm #`: Remove the item number specified by `#` from the boot options list.
- `bcfg boot mv #a #b`: Move the item number specified by `#a` to the position specified by `#b` in the boot options list.
- `bcfg boot add # file.efi "Description"`: Add a new boot option to the position in the boot options list specified by `#`. The new boot option references `file.efi` and is listed with the title specified by `Description`.

For example, `bcfg boot add 1 \EFI\HPUX\HPUX.EFI "HP-UX 11i"` adds an HP-UX 11i item as the first entry in the boot options list.

See the `help bcfg` command for details.

4. Exit the console and iLO 2 MP interfaces if you are finished using them.

Press **Ctrl-B** to exit the server console and return to the iLO 2 MP Main Menu. To exit the iLO 2 MP, enter `X` at the Main Menu.

## Standard HP-UX Booting

Use either of the following procedures to boot HP-UX:

- “Booting HP-UX (EFI Boot Manager)” (page 89)
- “Booting HP-UX (EFI Shell)” (page 90)

### Booting HP-UX (EFI Boot Manager)

From the **EFI Boot Manager Menu**, choose an item from the boot options list to boot HP-UX.

1. Access the **EFI Boot Manager Menu** for the server on which you want to boot HP-UX.  
Log in to the iLO 2 MP and enter `CO` to choose the system console.  
When accessing the console, confirm that you are at the EFI Boot Manager menu (the main EFI menu). If you are at another EFI menu, choose the **Exit** option from the submenus until you return to the screen with the **EFI Boot Manager** heading.
2. At the EFI Boot Manager menu, choose an item from the boot options list.  
Each item in the boot options list references a specific boot device and provides a specific set of boot options or arguments you use when booting the device.
3. Press **Enter** to initiate booting using the chosen boot option.
4. Exit the server console and iLO 2 MP interfaces when finished using them.
  - To exit the server console and return to the iLO 2 MP Main Menu, press **Ctrl-B**.
  - To exit the iLO 2 MP, enter `x` at the iLO 2 MP Main Menu.

## Booting HP-UX (EFI Shell)

From the EFI Shell environment, boot HP-UX on a device by first accessing the EFI System Partition (for example `fs0:`) for the root device, then entering `HPUX` to initiate the loader.

1. Access the EFI Shell environment for the server on which you want to boot HP-UX.  
Log in to the iLO 2 MP and enter `CO` to choose the system console.  
When accessing the console, confirm that you are at the **EFI Boot Manager Menu** (the main EFI menu). If you are at another EFI menu, choose the **Exit** option from the submenus until you return to the screen with the **EFI Boot Manager** heading.  
From the **EFI Boot Manager Menu**, choose the **EFI Shell** menu option to access the EFI Shell environment.
2. At the EFI Shell environment, issue the `map` command to list all currently mapped bootable devices.  
The bootable file systems of interest typically are listed as `fs0:`, `fs1:`, and so on.
3. Access the EFI System Partition (`fsX:` where `X` is the file system number) for the device from which you want to boot HP-UX.  
For example, enter `fs2:` to access the EFI System Partition for the bootable file system number 2. The EFI Shell prompt changes to reflect the file system currently accessed.  
The file system number might change each time it is mapped (for example, when the server boots, or when the `map -r` command is issued).
4. When accessing the EFI System Partition for the desired boot device, issue the `HPUX` command to initiate the `HPUX.EFI` loader on the device you are accessing.  
The full path for the loader is `\EFI\HPUX\HPUX.EFI`. When initiated, the loader references the `\EFI\HPUX\AUTO` file and proceeds to boot HP-UX using the default boot behavior specified in the `AUTO` file.  
You have 10 seconds to interrupt the automatic booting of the default boot behavior. Pressing any key during this 10-second period stops the HP-UX boot process and enables you to interact with the `HPUX.EFI` loader. To exit the loader (the `HPUX>` prompt) enter `exit` (this returns you to the EFI Shell).  
To boot the HP-UX operating system, do not type anything during the 10-second period given for stopping at the `HPUX.EFI` loader.



**NOTE:** Due to the type of server you purchased, your output may not exactly match the output shown here.

```
Shell> map
Device mapping table
  fs0 : Acpi(000222F0,269)/Pci(0|0)/Scsi(Pun8,Lun0)/HD(Part1,Sig72550000)
  blk0 : Acpi(000222F0,269)/Pci(0|0)/Scsi(Pun8,Lun0)
  blk1 : Acpi(000222F0,269)/Pci(0|0)/Scsi(Pun8,Lun0)/HD(Part1,Sig72550000)
  blk2 : Acpi(000222F0,269)/Pci(0|0)/Scsi(Pun8,Lun0)/HD(Part2,Sig72550000)
  blk3 : Acpi(000222F0,2A8)/Pci(0|0)/Scsi(Pun8,Lun0)
  blk4 : Acpi(000222F0,2A8)/Pci(0|1)/Scsi(Pun2,Lun0)
```

```
Shell> fs0:
```

```
fs0:\> hpux
```

```
(c) Copyright 1990-2002, Hewlett Packard Company.
All rights reserved
```

```
HP-UX Boot Loader for IA64 Revision 1.723
```

```
Press Any Key to interrupt Autoboot
\efi\hpux\AUTO ==> boot vmunix
Seconds left till autoboot - 9
```

5. Exit the server console and iLO 2 MP interfaces when finished.
  - To exit the server console and return to the iLO 2 MP Main Menu, enter **Ctrl-B**.
  - To exit the iLO 2 MP, enter X at the iLO 2 MP Main Menu.

## Booting HP-UX in Single-User Mode

From the EFI Shell environment, boot in single-user mode by stopping the boot process at the HP-UX .EFI interface (the HP-UX Boot Loader prompt, HP-UX>) and entering the `boot -is vmunix` command.

To boot HP-UX in single-user mode, follow these steps:

1. Access the EFI Shell environment for the system on which you want to boot HP-UX in single-user mode.

Log in to the iLO 2 MP and enter CO to choose the server console.

When accessing the console, confirm that you are at the **EFI Boot Manager Menu**. If you are at another EFI menu, choose the **Exit** option from the submenus until you return to the screen with the **EFI Boot Manager** heading.

From the EFI Boot Manager menu, choose the **EFI Shell** menu option to access the EFI Shell environment.

2. Access the EFI System Partition (`fsX`: where *X* is the file system number) for the device from which you want to boot HP-UX.
3. When accessing the EFI System Partition for the desired boot device, issue the HP-UX command to initiate the `\EFI\HP-UX\HP-UX .EFI` loader on the device you are accessing.
4. Boot to the HP-UX Boot Loader HP-UX> prompt by pressing any key within the 10 seconds given for interrupting the HP-UX boot process. Use the HP-UX .EFI loader to boot HP-UX in single-user mode in the next step.

After you press a key, the HP-UX .EFI interface (the HP-UX Boot Loader HP-UX> prompt), launches. For help using the HP-UX .EFI loader, enter the `help` command. To return to the EFI Shell, enter `exit`.

```
fs0:\> hpux
```

```
(c) Copyright 1990-2002, Hewlett Packard Company.
All rights reserved
```

```
Press Any Key to interrupt Autoboot
\efi\hpux\AUTO ==> boot vmunix
Seconds left till autoboot - 9
```

**[User Types A Key to Stop the HP-UX Boot Process and Access the HP-UX.EFI Loader ]**

Type 'help' for help

HPUX>

- At the HP-UX .EFI interface (the HP-UX Boot Loader HPUX> prompt), enter the `boot -is vmunix` command to boot HP-UX (the `/stand/vmunix` kernel) in single-user (`-is`) mode.



**NOTE:** Due to the type of server you purchased, your `sysset` output may not exactly match the output shown here.

```
HPUX> boot -is vmunix
> System Memory = 4063 MB
loading section 0
..... (complete)
loading section 1
..... (complete)
loading symbol table
loading System Directory(boot.sys) to MFS
....
loading MFSFILES Directory(bootfs) to MFS
.....
Launching /stand/vmunix
SIZE: Text:25953K + Data:3715K + BSS:3637K = Total:33306K

Console is on a Serial Device
Booting kernel...
```

- Exit the server console and iLO 2 MP interfaces when finished using them.
  - To exit the system console and return to the iLO 2 MP Main Menu, enter **Ctrl-B**.
  - To exit the iLO 2 MP, enter `X` at the iLO 2 MP Main Menu.

## Booting HP-UX in LVM Maintenance Mode

From the EFI Shell environment, boot in LVM-maintenance mode by stopping the boot process at the HP-UX .EFI interface (the HP-UX Boot Loader HPUX> prompt), and entering the `boot -lm vmunix` command.

Use the following procedure to boot HP-UX in Logical Volume Management (LVM) maintenance mode.

- Access the EFI Shell environment for the system on which you want to boot HP-UX in LVM-maintenance mode.

Log in to the iLO 2 MP and enter `CO` to choose the system console.

When accessing the console, confirm that you are at the **EFI Boot Manager Menu**. If you are at another EFI menu, choose the **Exit** option from the submenus until you return to the screen with the **EFI Boot Manager** heading.

From the EFI Boot Manager menu, choose the **EFI Shell** menu option to access the EFI Shell environment.

- Access the EFI System Partition (`fsX`: where `X` is the file system number) for the device from which you want to boot HP-UX.
- When accessing the EFI System Partition for the desired boot device, issue the **HP-UX** command to initiate the `\EFI\HP-UX\HP-UX.EFI` loader on the device you are accessing.
- Type any key within the 10 seconds given for interrupting the HP-UX boot process. This stops the boot process at the HP-UX .EFI interface (the HP-UX Boot Loader prompt, HPUX>).

5. At the HP-UX .EFI interface, enter the `boot -lm vmunix` command to boot HP-UX (the `/stand/vmunixkernel`) in LVM-maintenance (`-lm`) mode.
6. Exit the console and iLO 2 MP interfaces when finished using them.  
Press **Ctrl-B**) to exit the system console and return to the iLO 2 MP Main Menu. To exit the iLO 2 MP, enter `x` at the Main Menu.

## Shutting Down HP-UX

To shut down HP-UX running on a system, use the `shutdown` command. You have the following options when shutting down HP-UX:

- To shut down and reboot an HP-UX system, use the `shutdown -r` command.
- To shut down and halt (power off) an HP-UX system, use the `shutdown -h` command.

For details see the `shutdown(1M)` manpage and the following procedure:

1. From the HP-UX command line, issue the `shutdown` command to shut down the HP-UX operating system.
2. Log in to HP-UX running on the system that you want to shut down.  
You should log in to the iLO 2 MP for the server and use the Console menu to access the system console. Accessing the console through the iLO 2 MP enables you to maintain console access to the server after HP-UX has shut down.
3. Issue the `shutdown` command with the appropriate command-line options.

The command-line options you specify dictate the way in which HP-UX shuts down, and whether the server is rebooted.

Use the following list to choose an HP-UX shutdown option for your server:

- To shut down HP-UX and halt (power off) the server, issue the `shutdown -h` command.  
To reboot a halted server you must power on the server using the `PC` command at the iLO 2 MP Command menu.
- To shut down HP-UX and reboot the server, issue the `shutdown -r` command.

## Booting and Shutting Down HP OpenVMS



**NOTE:** Before booting or installing the OpenVMS operating system on the server, see the following website for the Server Errata Sheet for OpenVMS on the HP Integrity rx2660 Server: <http://www.docs.hp.com/en/hw.html>.

Once you have reached the Enterprise Servers, Workstations and Systems Hardware site, click the HP Integrity rx2660 Server link and refer to documentation specific to OpenVMS.

This section has procedures for booting and shutting down HP OpenVMS on the HP Integrity rx2660 server, and procedures for adding OpenVMS to the boot options list.

- To add an OpenVMS entry to the boot options list, see “Adding OpenVMS to the Boot Options List” (page 93).
- To boot HP OpenVMS on an entry-class HP Integrity server, see “Booting OpenVMS” (page 94).
- To shut down HP OpenVMS, see “Shutting Down OpenVMS” (page 96).

## Adding OpenVMS to the Boot Options List

On the rx2660 server, you can manage boot options using the command procedure `SYS$MANAGER:BOOT_OPTIONS.COM`. This procedure offers you the following options:

```
$ @sys$manager:boot_options.com
```

OpenVMS I64 Boot Manager Boot Options List Management Utility

- (1) ADD an entry to the Boot Options list
- (2) DISPLAY the Boot Options list
- (3) REMOVE an entry from the Boot Options list
- (4) MOVE the position of an entry in the Boot Options list
- (5) VALIDATE boot options and fix them as necessary
- (6) Modify Boot Options TIMEOUT setting

- (B) Set to operate on the Boot Device Options list  
 (D) Set to operate on the Dump Device Options list  
 (G) Set to operate on the Debug Device Options list

(E) EXIT from Boot Manager utility

You can also enter Ctrl-Y at any time to abort this utility.

Enter your choice:

To ADD an entry to the Boot Options list, select option (1):

Enter your choice: 1

Enter the device name (Enter "?" for a list of devices): ?

Device Name	Device Status	Error Count	Volume Label	Free Blocks	Trans Count	Mnt Cnt
\$1\$DGA700:	(NODE1) Mounted	0	(remote mount)			1
\$1\$DGA1510:	(NODE1) Mounted	0	(remote mount)			1
\$1\$DGA4000:	(NODE1) Mounted	0	WORK	130695025	1	9
\$26\$DKB5:	(NODE1) Mounted	0	DISK_V83	540949440	333	1

Device Name	Device Status	Error Count
EWA0:	Online	1
EWB0:	Online	0

EFI Built-in EFI Shell

Enter the device name (Enter "?" for a list of devices): \$26\$DKB5

Enter the desired position number (1,2,3,,,) of the entry.  
 To display the Boot Options list, enter "?" and press Return.  
 Position [1]: 10

Enter the value for VMS\_FLAGS in the form n,n.  
 VMS\_FLAGS [NONE]:

Enter a short description (do not include quotation marks).  
 Description ["\$26\$DKB5"]: V83 System Disk

efi\$bcfg: \$26\$dkb5 (Boot0008) Option successfully added

Enter your choice:



**NOTE:** Due to the type of server you purchased, your output may not exactly match the output shown here.

For more details, see HP OpenVMS Version 8.3 for Integrity Servers Upgrade and Installation Manual.

## Booting OpenVMS

To boot OpenVMS on an rx2660, use either of the following procedures:

- “Booting OpenVMS (EFI Boot Manager)” (page 95)
- “Booting HP OpenVMS (EFI Shell)” (page 95)

## Booting OpenVMS (EFI Boot Manager)

To boot OpenVMS from the **EFI Boot Manager** menu, follow these steps:

1. From the **EFI Boot Manager** menu, choose an item from the boot options list to boot OpenVMS using the chosen boot option.
2. Access the **EFI Boot Manager** menu for the server on which you want to boot OpenVMS. Log in to the iLO 2 MP and enter **CO** to choose the system console.



---

**NOTE:** When accessing the console, confirm that you are at the **EFI Boot Manager** menu (the main EFI menu). If you are at another EFI menu, choose the Exit option from the submenus until you return to the screen with the **EFI Boot Manager** heading.

---

3. At the **EFI Boot Manager** menu, choose an item from the boot options list.  
Each item in the boot options list references a specific boot device and provides a specific set of boot options or arguments to use when booting the device.
4. Press **Enter** to initiate booting using the chosen boot option.
5. Exit the console and iLO 2 MP interfaces when finished using them.
6. Enter **Ctrl-B** to exit the system console and return to the **iLO 2 MP Main Menu**.
7. Exit iLO 2 MP by entering **x** at the **iLO 2 MP Main Menu**.

## Booting HP OpenVMS (EFI Shell)

From the **EFI Shell** environment, to boot OpenVMS on a device, first access the bootable partition (for example **fs0 :**) for the root device and enter **\efi\vms\vms\_loader** to initiate the OpenVMS loader.

1. Access the EFI Shell environment for the server on which you want to boot OpenVMS. Log in to the iLO 2 MP and enter **CO** to choose the system console.



---

**NOTE:** When accessing the console, confirm that you are at the EFI Boot Manager menu (the main EFI menu). If you are at another EFI menu, choose the Exit option from the submenus until you return to the screen with the EFI Boot Manager heading.

---

2. From the **EFI Boot Manager** menu, choose the EFI Shell menu option to access the EFI Shell environment.
3. At the EFI Shell environment, issue the **map -fs** command to list all currently mapped bootable devices.  
The bootable file systems are listed as **fs0 :**, **fs1 :**, and so on.
4. Access the bootable partition (**fsX :** where **X** is the file system number) for the device you want to boot OpenVMS.  
For example, enter **fs2 :** to access the bootable partition for the bootable file system number 2.  
The EFI Shell prompt changes to reflect the file system currently accessed.



---

**NOTE:** The file system number might change each time it is mapped (for example, when the server boots, or when the **map -r** command is issued).

---

5. When accessing the bootable partition for the desired boot device, issue the **\efi\vms\vms\_loader** command to initiate the **vms\_loader.efi** loader on the device you are accessing.

```
fs5:> \efi\vms\vms_loader.efi
HP OpenVMS Industry Standard 64 Operating System, Version V8.3
© Copyright 1976-2006 Hewlett-Packard Development Company, L.P.
```

```
%DECnet-I-LOADED, network base image loaded, version = 05.13.00

%SMP-I-CPUTRN, CPU #02 has joined the active set.
%SMP-I-CPUTRN, CPU #03 has joined the active set.
%SMP-I-CPUTRN, CPU #01 has joined the active set.
%SYSINIT-I- waiting to form or join an OpenVMS Cluster
%VMScluster-I-LOADSECDB, loading the cluster security database
%EWA0, Auto-negotiation mode assumed set by console
%EWA0, Mer15704 located in 64-bit, 66-mhz PCI-X slot
%EWA0, Device type is BCM5704C (UTP) Rev B0 (21000000)
%EWB0, Auto-negotiation mode assumed set by console
%EWB0, Mer15704 located in 64-bit, 66-mhz PCI-X slot
%EWB0, Device type is BCM5704C (UTP) Rev B0 (21000000)
%PKA0, Copyright (c) 2001 LSI Logic, PKM V1.1.01 Chip LSISAS1068
%EWA0, Link up: 1000 mbit, full duplex, flow control disabled
```

---



**NOTE:** Due to the type of server you purchased, your output may not exactly match the output shown here.

---

6. Exit the console and iLO 2 MP interfaces when finished using them.
7. Enter **Ctrl-B** to exit the system console and return to the **iLO 2 MP Main Menu**. To exit the iLO 2 MP, enter x at the **iLO 2 MP Main Menu**.

## Shutting Down OpenVMS

This section describes how to shut down the HP OpenVMS operating system on an rx2660 server. From the OpenVMS DCL prompt, issue the @SYS\$SYSTEM: SHUTDOWN command to shut down the OpenVMS operating system. Use the following steps:

1. Log in to OpenVMS running on the server that you want to shut down.  
Log in to the iLO 2 MP for the server and use the Console menu to access the system console. Accessing the console through the iLO 2 MP enables you to maintain console access to the server after HP OpenVMS has shut down.



2. At the OpenVMS DCL prompt issue the `@SYS$SYSTEM:SHUTDOWN` command and specify the shutdown options in response to the prompts given.

```
$@sys$system:shutdown
```

```
SHUTDOWN -- Perform an Orderly System Shutdown
           on node NODE1
```

```
How many minutes until final shutdown [0]:
```

```
Reason for shutdown [Standalone]:
```

```
Do you want to spin down the disk volumes [NO]?
```

```
Do you want to invoke the site-specific shutdown procedure [YES]?
```

```
Should an automatic system reboot be performed [NO]?
```

```
When will the system be rebooted [later]:
```

```
Shutdown options (enter as a comma-separated list):
```

```
REMOVE_NODE           Remaining nodes in the cluster should adjust quorum
CLUSTER_SHUTDOWN      Entire cluster is shutting down
REBOOT_CHECK          Check existence of basic system files
SAVE_FEEDBACK         Save AUTOGEN feedback information from this boot
DISABLE_AUTOSTART     Disable autostart queues
POWER_OFF              Request console to power-off the system
BIB_STATE             Request console to reboot all CPUs to the Itanium BIB state
```

```
Shutdown options [NONE]: REBOOT_CHECK
```

```
%SHUTDOWN-I-BOOTCHECK, performing reboot consistency check...
```

```
%SHUTDOWN-I-CHECKOK, basic reboot consistency check completed
```

```
%SHUTDOWN-I-OPERATOR, this terminal is now an operator's console
```

```
%SHUTDOWN-I-DISLOGINS, interactive logins will now be disabled
```

```
%SET-I-INTSET, login interactive limit = 0, current interactive value = 1
```

```
%SHUTDOWN-I-SHUTNET, the DECnet network will now be shut down
```



**NOTE:** HP OpenVMS I64 currently does not support the `POWER_OFF` shutdown option.

Due to the type of server you purchased, your output may not exactly match the output shown here.

---

## Booting and Shutting Down Microsoft Windows

This section describes how to boot and shut down Microsoft Windows on entry-class HP Integrity servers and how to add Windows entries to the system boot options list.

- “Adding Microsoft Windows to the Boot Options List” (page 97)
- “Booting the Microsoft Windows Operating System” (page 99)
- “Shutting Down Microsoft Windows” (page 100)

### Adding Microsoft Windows to the Boot Options List

To add a Microsoft Windows entry to the system boot options list you must do so from EFI by using the `\MSUtil\nvrboot.efi` utility to import boot options from the `EFI\Microsoft\WINNT50\Boot0...` file on the device from which Windows is loaded.

This procedure adds the Microsoft Windows item to the boot options list.



---

**NOTE:** On HP Integrity servers, the operating system installer automatically adds an entry to the boot options list.

---

1. Access the EFI Shell environment.

Log in to the iLO 2 MP and enter CO to access the system console.

When accessing the console, confirm that you are at the EFI Boot Manager menu (the main EFI menu). If you are at another EFI menu, choose the **Exit** option from the submenus until you return to the screen with the **EFI Boot Manager** heading.

From the EFI Boot Manager menu, choose the **EFI Shell** menu option to access the EFI Shell environment.

2. Access the EFI System Partition (fsX: where X is the file system number) for the device from which you want to boot Windows.

For example, enter fs2: to access the EFI System Partition for the bootable file system number 2. The EFI Shell prompt changes to reflect the file system currently accessed.

The full path for the Microsoft Windows loader is

`\efi\microsoft\winnt50\ia64ldr.efi` and it should be on the device you are accessing. However, you must only initiate this loader from the EFI Boot Menu and not from the EFI Shell.

3. List the contents of the `\EFI\Microsoft\WINNT50` directory to identify the name of the Windows boot option file (Boot00nn) that you want to import into the system boot options list.

```
fs0:\> ls EFI\Microsoft\WINNT50
Directory of: fs0:\EFI\Microsoft\WINNT50

    09/18/03   11:58a <DIR>           1,024  .
    09/18/03   11:58a <DIR>           1,024  ..
    12/18/03   08:16a                354   Boot0001
                1 File(s)           354 bytes
                2 Dir(s)
```

```
fs0:\>
```

4. At the EFI Shell environment, issue the `\MSUtil\nvrboot.efi` command to launch the Microsoft Windows boot options utility.

```
fs0:\> msutil\nvrboot

NVRBOOT: OS Boot Options Maintenance Tool [Version 5.2.3683]

    1. SUSE SLES 10
    2. HP-UX Primary Boot: 0/0/1/0/0.2.0
    * 3. Windows Server 2003, Datacenter
    4. EFI Shell [Built-in]

    * = Windows OS boot option

(D)isplay (M)odify (C)opy E(x)port (I)mport (E)rase (P)ush (H)elp (Q)uit

Select>
```

5. Use the Import command to import the Window boot option file.

```
Select> i
Enter IMPORT file path: \EFI\Microsoft\WINNT50\Boot0001
Imported Boot Options from file: \EFI\Microsoft\WINNT50\Boot0001

Press enter to continue
```



---

**NOTE:** Due to the type of server you purchased, your output may not exactly match the output shown here.

---

6. Enter **Q** to quit the NVRBOOT utility, and exit the console and iLO 2 MP interfaces if you are finished using them.  
Enter **Ctrl-B** to exit the system console and return to the iLO 2 MP Main Menu. To exit the iLO 2 MP, enter **x** at the Main Menu.

## Booting the Microsoft Windows Operating System

Boot the Windows Server 2003 operating system on an HP Integrity server by using the EFI Boot Manager to choose the appropriate Windows item from the boot options list. For information on shutting down the Windows operating system, see “Shutting Down Microsoft Windows” (page 100).

1. From the EFI Boot Manager menu, choose an item from the boot options list to boot Windows using the chosen boot option.
2. Access the EFI Boot Manager menu for the server on which you want to boot Windows.

Log in to the iLO 2 MP and enter **CO** to choose the system console.

When accessing the console, confirm that you are at the EFI Boot Manager menu (the main EFI menu). If you are at another EFI menu, choose the **Exit** option from the submenus until you return to the screen with the **EFI Boot Manager** heading.

3. At the EFI Boot Manager menu, choose an item from the boot options list.  
Each item in the boot options list references a specific boot device and provides a specific set of boot options or arguments to be used when booting the device.
4. Press **Enter** to initiate booting using the chosen boot option.
5. Once Windows begins loading, wait for the Special Administration Console (SAC) to become available.

The SAC interface provides a text-based administration tool that is available from the system console. For details see the SAC online help (enter **?** at the SAC> prompt).

```
Loading.: Windows Server 2003, Datacenter
Starting: Windows Server 2003, Datacenter
```

```

                          Starting Windows...
*****
Computer is booting, SAC started and initialized.

Use the "ch -?" command for information about using channels.
Use the "?" command for general help.

SAC>
```



---

**NOTE:** Due to the type of server you purchased, your output may not exactly match the output shown here.

---

6. Exit the console and iLO 2 MP interfaces when finished using them.  
Enter **Ctrl-B** to exit the console and return to the iLO 2 MP Main menu. To exit the iLO 2 MP, enter **x** at the Main menu.

## Shutting Down Microsoft Windows

Shut down the Windows operating system on HP Integrity servers by using the **Start** menu or the `shutdown` command.



**CAUTION:** Do not shut down Windows using Special Administration Console (SAC) `restart` or `shutdown` commands under normal circumstances.

Issuing `restart` or `shutdown` at the `SAC>` prompt causes the server to restart or shutdown immediately and can result in the loss of data.

Instead use the Windows **Start** menu or the `shutdown` command to shut down gracefully.

To shut down Windows use either of the following methods.

- Choose **Shut Down** from the **Start** menu and choose either **Restart** or **Shut down** from the pull-down menu.

The **Restart** menu item shuts down and restarts the server. The **Shut down** menu item shuts down the server.

You can use this method when using a graphical interface to the server.

- Issue the `shutdown` command from the Windows command line.

For more information, see `""` (page 100).

You can issue this command from a command prompt through the Special Administration Console (SAC) or from any other command line.

The Windows `shutdown` command includes the following options:

- `/s` Shuts down and halts (power off) the server. This is the equivalent of **Start—>Shut Down, Shut down**. To power on the server, use the `iLO 2 MP PC` command.
- `/r` Shuts down and restarts the server. This is the equivalent of **Start—>Shut Down, Restart**.
- `/a` Aborts a server shutdown.
- `/t xxx` Sets the timeout period before shutdown to `xxx` seconds. The timeout period ranges from 0–600, with a default of 30.

See the `help shutdown Windows` command for details.

### Windows Shutdown from the Command Line

From the Windows command line, issue the `shutdown` command to shut down the operating system.

1. Log in to Windows running on the server that you want to shut down.

For example, access the system console and use the Windows SAC interface to start a command prompt, from which you can issue Windows commands to shut down the server.

2. Check to see whether any users are logged in.

Use the `query user` or `query session` command.

3. Issue the shut down command and the appropriate options to shut down the Windows Server 2003 on the server.

You have the following options when shutting down Windows:

- To shut down Windows and reboot: `shutdown /r` or choose the **Start → Shut Down** action and choose **Restart** from the pull-down menu.
- To shut down Windows and halt (power off server hardware): `shutdown /s` or choose the **Start → Shut Down** action and choose **Shut down** from the pull-down menu.  
To reboot a halted server you must power on the server using the PC command at the iLO 2 MP Command menu.
- To abort a shutdown (stop a shutdown that has been initiated): `shutdown /a`.

For example:

```
shutdown /r /t 60 /c "Shut down in one minute."
```

This command initiates a Windows system shutdown and reboot after a timeout period of 60 seconds. The `/c` option specifies a message that is broadcast to any other users of the server.

## Booting and Shutting Down Linux

This section covers booting and shutting down Linux on entry-class HP servers. Procedures for Red Hat Enterprise Linux and SuSE Linux Enterprise Server are given in this section.

- To add a Linux entry to the boot options list, see “Adding Linux to the Boot Options List” (page 101).
- To boot Linux on entry-class HP Integrity servers, use the following procedures.
  - See “Booting the Red Hat Enterprise Linux Operating System” (page 102) for details on Red Hat Enterprise Linux.
  - See “Booting the SuSE Linux Enterprise Server Operating System” (page 103) for details on SuSE Linux Enterprise Server.
- To shut down either Red Hat Enterprise Linux or SuSE Linux Enterprise Server, see “Shutting Down Linux” (page 104).

## Adding Linux to the Boot Options List

This section describes how to add a Linux entry to the system boot options list. The processes for adding both Red Hat Enterprise Linux and SuSE Linux Enterprise Servers are given here.

You can add the `\EFI\redhat\elilo.efi` loader or the `\efi\SuSE\elilo.efi` loader to the boot options list from the EFI Shell or EFI Boot Configuration menu (or in some versions of EFI, the Boot Option Maintenance Menu).



**NOTE:** On HP Integrity servers, the operating system installer automatically adds an entry to the boot options list.

---

1. Access the EFI Shell environment.

Log in to the iLO 2 MP and enter `CO` to access the system console.

When accessing the console, confirm that you are at the EFI Boot Manager menu (the main EFI menu). If you are at another EFI menu, choose the **Exit** option from the submenus until you return to the screen with the `EFI Boot Manager` heading.

From the EFI Boot Manager menu, choose the **EFI Shell** menu option to access the EFI Shell environment.

2. Access the EFI System Partition (`fsX`: where *X* is the file system number) for the device from which you want to boot Linux.

For example, enter `fs2`: to access the EFI System Partition for the bootable file system number 2. The EFI Shell prompt changes to reflect the file system currently accessed.

The full path for the Red Hat Enterprise Linux loader is `\EFI\redhat\elilo.efi` and it should be on the device you are accessing.

The full path for the SuSE Linux Enterprise Server loader is `\efi\SuSE\elilo.efi` and it should be on the device you are accessing.

3. At the EFI Shell environment, use the `bcfg` command to manage the boot options list.

The `bcfg` command includes the following options for managing the boot options list:

- `bcfg boot dump`: Displays all items in the boot options list for the server.
- `bcfg boot rm #`: Removes the item number specified by *#* from the boot options list.
- `bcfg boot mv #a #b`: Moves the item number specified by *#a* to the position specified by *#b* in the boot options list.
- `bcfg boot add # file.efi "Description"`: Adds a new boot option to the position in the boot options list specified by *#*. The new boot option references *file.efi* and is listed with the title specified by *Description*.

For example, `bcfg boot add 1 \EFI\redhat\elilo.efi "Red Hat Enterprise Linux"` adds a Red Hat Enterprise Linux item as the first entry in the boot options list.

Likewise, `bcfg boot add 1 \efi\SuSE\elilo.efi "SLES 10"` adds a SuSE Linux item as the first entry in the boot options list.

For details, see the `help bcfg` command.

4. Exit the console and iLO 2 MP interfaces if you are finished using them.

Enter **Ctrl-B** to exit the system console and return to the iLO 2 MP Main Menu. To exit the iLO 2 MP, enter `x` at the Main Menu.

## Booting the Red Hat Enterprise Linux Operating System

You can boot the Red Hat Enterprise Linux operating system on HP Integrity servers using either of these methods:

- Choose a Red Hat Enterprise Linux entry from the EFI Boot Manager menu.

To load the Red Hat Enterprise Linux operating system at the EFI Boot Manager menu, choose its entry from the list of boot options.

Choosing a Linux entry from the boot options list boots the operating system using ELILO.EFI loader and the `elilo.conf` file.

- Initiate the ELILO.EFI Linux loader from the EFI Shell.

For details, see "" (page 103).

On a Red Hat Enterprise Linux boot device EFI System Partition, the full paths to the loader and configuration files are as follows: `\EFI\redhat\elilo.efi` and `\EFI\redhat\elilo.conf`

After choosing the file system for the boot device (for example, `fs0`;) initiate the Linux loader from the EFI Shell prompt by entering the full path for the ELILO.EFI loader.

By default the ELILO.EFI loader boots Linux using the kernel image and parameters specified by the default entry in the `elilo.conf` file on the EFI System Partition for the boot device.

To interact with the ELILO.EFI loader, interrupt the boot process (for example, enter a space) at the `ELILO boot` prompt. To exit the ELILO.EFI loader, use the `exit` command.

## Booting Red Hat Enterprise Linux from the EFI Shell

Use this procedure to boot Red Hat Enterprise Linux from the EFI Shell.

1. Access the EFI Shell.

From the system console, choose the **EFI Shell** entry from the EFI Boot Manager menu to access the shell.

2. Access the EFI System Partition for the Red Hat Enterprise Linux boot device.

Use the map EFI Shell command to list the file systems (`fs0`, `fs1`, and so on) that are known and mapped.

To choose a file system to use, enter its mapped name followed by a colon (:). For example, to operate with the boot device that is mapped as `fs3`, enter `fs3:` at the EFI Shell prompt.

3. Enter `ELILO` at the EFI Shell command prompt to launch the `ELILO.EFI` loader.

If needed, you can specify the loader path by entering `\EFI\redhat\elilo` at the EFI Shell command prompt.

4. Allow the `ELILO.EFI` loader to proceed with booting the Red Hat Enterprise Linux kernel.

By default, the `ELILO.EFI` loader boots the kernel image and options specified by the default item in the `elilo.conf` file.

To interact with the `ELILO.EFI` loader, interrupt the boot process (for example, enter a space) at the `ELILO boot` prompt. To exit the loader use the `exit` command.

## Booting the SuSE Linux Enterprise Server Operating System

You can boot the SuSE Linux Enterprise Server 10 operating system on HP Integrity servers using either of these methods:

- Choose a SuSE Linux Enterprise Server entry from the EFI Boot Manager menu.

To load the SuSE Linux Enterprise Server operating system at the EFI Boot Manager menu, choose its entry from the list of boot options.

Choosing a Linux entry from the boot options list boots the operating system using `ELILO.EFI` loader and the `elilo.conf` file.

- Initiate the `ELILO.EFI` Linux loader from the EFI Shell. For more information, see [“Booting SuSE Linux Enterprise Server from the EFI Shell”](#) (page 103).

On a SuSE Linux Enterprise Server boot device EFI System Partition, the full paths to the loader and configuration files are as follows: `\efi\SuSE\elilo.efi` and `\efi\SuSE\elilo.conf`.

After choosing the file system for the boot device (for example, `fs0:`) you can initiate the Linux loader from the EFI Shell prompt by entering the full path for the `ELILO.EFI` loader.

By default, the `ELILO.EFI` loader boots Linux using the kernel image and parameters specified by the default entry in the `elilo.conf` file on the EFI System Partition for the boot device.

To interact with the `ELILO.EFI` loader, interrupt the boot process (for example, enter a space) at the `ELILO boot` prompt. To exit the `ELILO.EFI` loader, use the `exit` command.

## Booting SuSE Linux Enterprise Server from the EFI Shell

Use this procedure to boot SuSE Linux Enterprise Server 10 from the EFI Shell.

1. Access the EFI Shell.

From the system console, choose the **EFI Shell** entry from the EFI Boot Manager menu to access the shell.

2. Access the EFI System Partition for the SuSE Linux Enterprise Server boot device.  
Use the `map` EFI Shell command to list the file systems (`fs0`, `fs1`, and so on) that are known and mapped.  
To choose a file system to use, enter its mapped name followed by a colon (:). For example, to operate with the boot device that is mapped as `fs3`, enter `fs3 :` at the EFI Shell prompt.
3. Enter **ELILO** at the EFI Shell command prompt to launch the `ELILO.EFI` loader.  
If needed, you can specify the loader path by entering `\efi\SuSE\elilo` at the EFI Shell command prompt.
4. Allow the `ELILO.EFI` loader to proceed with booting the SuSE Linux kernel.  
By default, the `ELILO.EFI` loader boots the kernel image and options specified by the default item in the `elilo.conf` file.  
To interact with the `ELILO.EFI` loader, interrupt the boot process (for example, enter a space) at the `ELILO boot` prompt. To exit the loader, use the `exit` command.

## Shutting Down Linux

Use the `shutdown` command to shut down Red Hat Enterprise Linux or SuSE Linux Enterprise Server.

The Red Hat Enterprise Linux and SuSE Linux Enterprise Server `shutdown` command has the following options:

- h Halts (power off) after shutdown.  
Use the `PC` command at the `iLO 2 MP Command` menu to manually power on or power off server hardware, as needed.
- r Reboots after shutdown.
- c Cancels an already running shutdown.
- time* When to shut down. (Required.) You can specify *time* in any of the following ways:
  - Absolute time in the format `hh:mm`; *hh* is the hour (one or two digits) and *mm* is the minute of the hour (two digits).
  - Number of minutes to wait in the format `+m`, in which *m* is the number of minutes.
  - `now` to immediately shut down; this is equivalent to using `+0` to wait zero minutes.

For details, see the `shutdown` (8) Linux manpage. Also see the Linux manpage for the `poweroff` command.

1. From the command line for Red Hat Enterprise Linux or SuSE Linux Enterprise Server, issue the `shutdown` command to shut down the operating system.
2. Log in to Linux running on the server you want to shut down.
3. Issue the `shutdown` command with the desired command-line options, and include the required *time* argument to specify when the operating system shutdown is to occur.  
For example, `shutdown -r +20` shuts down and reboots the server in twenty minutes.



---

# 5 Troubleshooting

The purpose of this chapter is to provide a preferred methodology (strategies and procedures) and tools for troubleshooting rx2660 server error and fault conditions.

This chapter addresses the following topics:

- “Methodology” (page 105).
- “Troubleshooting Tools” (page 112).
- “Errors and Reading Error Logs” (page 119).
- “Supported Configurations” (page 122).
- “CPU/Memory/SBA” (page 124).
- “Power Subsystem ” (page 129).
- “Cooling Subsystem” (page 130).
- “I/O Backplane (LBAs/Ropes/PDH/PCI-X/PCIe Slots)” (page 131).
- “Management Subsystem” (page 133).
- “I/O Subsystem (SAS/DVD/HDD)” (page 134).
- “Bootting ” (page 135).
- “Firmware” (page 136).
- “Server Interface (System Console)” (page 137).
- “Environment ” (page 138).
- “Reporting Your Problems to HP” (page 138).

## Methodology

### General Troubleshooting Methodology

There are multiple entry points to the troubleshooting process, dependent upon your level of troubleshooting expertise, the tools/processes/procedures which you have at your disposal, and the nature of the system fault or failure.

Typically, you select from a set of symptoms, ranging from very simple (system LED is blinking) to the most difficult Machine Check Abort (MCA) has occurred. The following is a list of symptom examples:



**NOTE:** Your output might differ from the output in the examples in this book depending on your server and its configuration.

---

- Front panel LED blinking
- System alert present on console
- System won't power-up
- System won't boot
- Error/Event Message received
- Machine Check Abort (MCA) occurred

Narrow down the observed problem to the specific troubleshooting procedure required. Isolate the failure to a specific part of the server, so you can perform more detailed troubleshooting. For example:

- Problem- Front panel LED blinking



---

**NOTE:** The front panel health LEDs flash amber with a warning indication, or flash red with a fault indication.

---

- System Alert on console?

Analyze the alert by using the system event log (SEL), to identify the last error logged by the server. Use the iLO 2 MP commands to view the SEL, either through the iLO 2 MP serial text interface, or through telnet, SSH, or through the web GUI on the iLO 2 MP LAN.

You should now have a good idea about which area of the system requires further analysis. For example, if the symptom was “system won’t power-up”, the initial troubleshooting procedure may indicate a problem with the dc power rail not coming up after the power switch was turned on.

You have now reached the point where the failed CRU has been identified and needs to be replaced. Perform the specific removal and replacement procedure, and verification steps (see Chapter 6: “Removing and Replacing Server Components” (page 140) for the appropriate procedures).



---

**NOTE:** If multiple CRUs are identified as part of the solution, a fix cannot be guaranteed unless all identified failed CRUs are replaced.

---

There may be specific recovery procedures you need to perform to finish the repair. For example, if the system board is replaced, you need to restore customer specific information.

Should a failure occur, the System Insight Display LEDs and the system event log (SEL) help you identify the problem or CRU:

- LEDs. The front panel LEDs and LAN LEDs of the server change color and blink to help identify specific problems.
- The System Event Log (SEL) provides detailed information about the errors identified by the LEDs.

For system alerts of levels 3-5, the attention condition on the system LED can be cleared by accessing the logs using the `sl` command, available in the iLO 2 MP Main Menu. To access the iLO 2 MP from the console serial port, enter **Ctrl-B** or **ESC**.

If the LEDs and SEL do not give you enough information to identify the problem, HP also provides diagnostic tools with each operating system (see “Troubleshooting Tools” (page 112) for more details).



---

**NOTE:** Always check the iLO 2 MP system event logs (SEL) in the case of a blinking yellow or red front panel LED, before replacing any hardware. The default display mode is **Keyword** mode. To view the error messages more easily, change to **Text** mode.

---

## Recommended Troubleshooting Methodology

The recommended methodology for troubleshooting a server error or fault is as follows:

1. Consult the system console for any messages, emails, etc., pertaining to a server error or fault.
2. View the front panel LEDs (power, external health, internal health, and system health), either locally, or remotely through the iLO 2 MP `vfp` command.

3. Compare the state of the server LEDs (off; flashing or steady; red, green, or amber) with the LED states listed in the LED Panel State Table in this section.
4. Go to the step number of the Basic Low End Troubleshooting Table, as specified in the right column of the LED Panel State Table, located in the row which corresponds to your front panel LED display state.
5. Read the symptom/condition information in the left column of the Basic Low End Troubleshooting Table.
6. Perform the action(s) specified in the **Action** column.
7. If you need more details, see the appropriate subsection of this chapter, where this information is provided in the **Action** column. The action you are directed to perform may be to access and read one or more error logs (System Event Log and/or Forward Progress Log).

While we do suggest that all users follow the recommended troubleshooting methodology, and use the Basic and Advanced Troubleshooting Tables in the next subsection, as a more experienced troubleshooter you may elect to go directly to the subsection of this chapter (or section of this manual) which corresponds to your own entry point of choice.

Table 5-1 table provides the corresponding subsection or location title for these different entry points (for example, if you would prefer to start by examining the logs, you can go directly to the subsection entitled “Errors and Reading Error Logs” (page 119)):

**Table 5-1 Troubleshooting Entry Points**

Entry Point	Subsection or Location
Front panel/System Insight Display LEDs	“Basic and Advanced Troubleshooting Tables” (page 107) and “Troubleshooting Tools” (page 112)
System Event Log and Forward Progress Logs	“Errors and Reading Error Logs” (page 119)
Offline and Online Diagnostics/INIT button	“Troubleshooting Tools” (page 112)
System Event Analyzer (SEA)	“Troubleshooting Tools” (page 112) (see also <a href="http://h18023.www1.hp.com/support/svctools/webes">http://h18023.www1.hp.com/support/svctools/webes</a> for more information about this tool)

## Basic and Advanced Troubleshooting Tables

The following troubleshooting tables are designed for use by both trained and untrained support personnel. They should be the first tool used to determine the symptom(s) or condition of a suspect server. Be aware that the state of the front panel LEDs can be viewed locally, or remotely (using the `vfp` command from the iLO 2 MP).

The tables are designed to cover troubleshooting symptoms from ac power-on up to booting the operating system (OS), specifically in Steps 1-5. In most cases, the Table 5-2: “Front Panel LED States” (page 108) identifies the step number where troubleshooting should begin in the Table 5-3: “Basic Low End Troubleshooting” (page 108). Alternatively, you can skip Table 5-2, and start with Step 1 in Table 5-3, sequencing through the table steps to locate the symptom/condition most descriptive of your current server status; this becomes the first step in your troubleshooting procedure. Where appropriate, an action or actions prescribed in the “Action” column of Table 5-3 is followed by a reference to the corresponding subsection of this chapter for further information.



**NOTE:** In the table which follows, the Unit Identifier (UID)/locator LED has not been included, because it is not used directly for troubleshooting rx2660 servers. However, indirectly, it can provide useful system information. When the UID is blue, this is an indication that the BMC is working.

Similarly, the INIT Button, which is a momentary switch with pinhole access, that is used to cause a system INIT or Transfer of Control (ToC), is not discussed in the following tables either. It basically is like a system reset, preserving the entire memory image, so that you can obtain a crash dump and receive OS error information. This button can be used to recover a hung system, and to obtain information useful for debugging -- it is less harsh than a power reset.

**NOTE:** In Table 5-2, LED states indicating error conditions are provided in uppercase (for example, "FLASHING AMBER").

**Table 5-2 Front Panel LED States**

System Health	Internal Health	External Health	System Power	Basic Low End Troubleshooting Table Step Number
Off	Off	Off	Off	1 in Table 5-3
Off	Off	Off	STEADY AMBER	2a in Table 5-3
FLASHING AMBER OR RED	Off or steady green	FLASHING AMBER	Steady green	2b/2c in Table 5-3
Off	FLASHING AMBER	Steady green	Steady green	8b in Table 5-4
FLASHING AMBER OR RED	FLASHING AMBER	Steady green	Steady green	3a/3b in Table 5-3
Off	Steady green	Steady green	Steady green	4a, 4b, 4c, and 4d in Table 5-3
Steady green/off	Steady green	Steady green	Steady green	8a in Table 5-4
Steady green	Steady green	Steady green	Steady green	5, 6, and 7 in Tables 5-3 and 5-4

**Table 5-3 Basic Low End Troubleshooting**

Step	Condition	Action
1	Server appears "dead" -- no front panel LEDs are on, and no fans are running.	Nothing is logged for this condition. 1. For new server installations, review the install procedures. 2. Verify that the power cord(s) are connected to both the power supplies and to the ac receptacle(s). 3. Verify that ac power, at the proper ac voltage levels, is available to the receptacle(s). 4. Check the front panel connector and the cable to the rest of the system. 5. If the integrated power button LED on front panel remains off, then re-seat the power supplies, replace the power cords, and replace the bulk power supplies, in that order (See "Power Subsystem " (page 129)for more details).  The preceding problem is fixed when the front panel LED states are as follows: system health is off; internal health is off; external health is off; and power is steady amber.
2a	Server does not power on after front panel power button is momentarily pressed (less than four seconds). NOTE: This step assumes BMC is running	A fatal fault has been detected and logged, attempting to power on the server (system health is off, internal health is off, external health is off, and power is steady amber). 1. Examine each power supply LED -- if not solid green, then replace power supply (see "Power Subsystem " (page 129) for more details). 2. Examine the iLO

**Table 5-3 Basic Low End Troubleshooting** *(continued)*

Step	Condition	Action
		<p>2 MP logs for events related to bulk power supplies (see “Power Subsystem ” (page 129) for details).</p> <p>The preceding problem is fixed when the front panel LEDs are as follows: system health is off, internal health is off, external health is off, and power is solid green.</p>
2b	Both front panel system health and external health LEDs are flashing amber.	<p>A warning or critical failure has been detected and logged after server powers on (system health is flashing amber, internal health is off /solid green, external health is flashing amber, and power is steady green). Examine each power supply LED. If not solid green, replace power supply (see “Power Subsystem ” (page 129)for details).</p> <p>The preceding problem is fixed when iLO 2 MP logs are read, and the front panel LED states are as follows: system health is off, internal health is off/ steady green, external health is steady green, and power is steady green.</p>
2c	Front panel system health LED is flashing red and external health LED is flashing amber.	<p>A fatal fault has been detected and logged after server powers on (system health is flashing red, internal health is off/steady green, external health is flashing amber, and power is steady green). 1. Examine each power supply LED. If not solid green, replace power supply (see “Power Subsystem ” (page 129)for details).</p> <p>The preceding problem is fixed when iLO 2 MP logs are read, and the front panel LED states are as follows: system health is off, internal health is off/steady green, external health is steady green, power is steady green.</p>
3a	Both front panel system health LED and internal health LED are flashing amber.	<p>A warning or critical failure has been detected and logged, while booting or running system firmware (system health is flashing amber, internal health is flashing amber, external health is steady green, and power is steady green). 1. Check diagnostic LED panel to identify failed or faulty internal CRU (See “Troubleshooting Tools” (page 112) for more details).</p> <p>The preceding problem is fixed when a redundant, internal CRU is replaced, iLO 2 MP logs are read, and the front panel LED states are as follows: system health is off, internal health is steady green, external health is steady green, and power is steady green.</p>
3b	Front panel system health LED is flashing red and internal health LED is flashing amber.	<p>A fatal fault has been detected and logged, while booting or running system firmware (system health is flashing red, internal health is flashing amber, external health is steady green, and power is steady green). 1. Check diagnostic LED panel to identify failed or faulty internal CRU (See “Troubleshooting Tools” (page 112) for details.).</p> <p>The preceding problem is fixed when a redundant, internal CRU is replaced, iLO 2 MP logs are read, and the front panel LED states are as follows: system health is off, internal health is</p>

**Table 5-3 Basic Low End Troubleshooting** *(continued)*

Step	Condition	Action
		steady green, external health is steady green, and power is steady green.
4a	Cannot see iLO 2 MP prompt on system console -- server power is off/on.	<p>Front panel LEDs indicate that the server is either booting or running system firmware, or is booting or running the OS (system health is off/steady green, internal health is steady green, external health is steady green, and power is steady green). Nothing may be logged for this condition.</p> <p>1. The most common reasons for this are console cabling issues, console configuration issues, etc. Check these issues first.</p> <p>2. Examine iLO 2 MP heartbeat LED. 3. If off, then iLO 2 MP is not operational; if flashing amber, then ROM error exists. 4. Reset iLO 2 MP, by using the pinhole reset button on the rear panel of the server. 5. If no change, replace the system board (See “Management Subsystem” (page 133) for details.).</p> <p>The preceding problem is fixed when iLO 2 MP heartbeat LED and the system health led are steady green.</p>
4a (cont.)	Still no iLO 2 MP prompt on system console.	<p>Nothing may be logged for this condition (note: if the iLO 2 MP is off, the system health is off as well). Front panel LEDs indicate that the server is either booting or running the OS. 1. Verify that the proper terminal type is set: Supported settings are hpterm, VT100+ (default), and VTUTF8. 2. Verify that the RS-232C configuration matches between the server and the local console or modem (See “Supported Configurations” (page 122) for details). 3. Look for loose, damaged, or disconnected power and signal cables on the I/O backplane.</p> <p>The preceding problem is fixed when iLO 2 MP menu appears on the system console, and the system health is steady green.</p>
4b	Cannot see EFI prompt on system console.	<p>Nothing may be logged for this condition (system health is off, internal health is steady green, external health is steady green, and power is steady green). Front panel LEDs indicate that the server is either booting or running the OS. 1. Examine the state (flashing or solid on) of the three LEDs, located in the back left corner of the server, visible through the perforations in the server. Server (logic and system firmware) stages are tracked by the PDH FPGA, using these three LEDs (see “Troubleshooting Tools” (page 112) for more LED info). 2. Examine the iLO 2 MP logs for entries related to processors, processor power modules (PPMs), shared memory, and core I/O devices (see “Errors and Reading Error Logs” (page 119) for details).</p> <p>The preceding problem is fixed when EFI menu appears on the system console, and system firmware booting completes.</p>
4c	Cannot find a boot disk or removable media drive.	Nothing may be logged for this condition (system health is off, internal health is steady green, external health is steady green, and power is

**Table 5-3 Basic Low End Troubleshooting** (continued)

Step	Condition	Action
		<p>steady green). 1. Examine the boot device, to determine if it is plugged into its drive bay properly. 2. Examine the drive cabling for any problems. 3. Examine the boot path settings. 4. Examine the iLO 2 MP logs for entries related to processors, processor power modules (PPMs), shared memory, and core I/O devices (see “Errors and Reading Error Logs” (page 119) for more details).</p> <p>The preceding problem is fixed, when all boot devices are found.</p>
4d	There are RAID channel redundancy failures.	<p>Nothing is logged for this condition (system health is off, internal health is steady green, external health is steady green, and power is steady green). Examine the LED next to each RAID connector, and replace the RAID HBA (if this LED is either steady amber or steady red, it indicates RAID drives are degraded or corrupted, respectively).</p> <p>The preceding problem is fixed when all of these LEDs remain off, after next power on.</p>
5	Cannot see OS prompt on system console.	<p>Front panel LEDs indicate that the server power is turned on, and that the server is either booting or running the OS. Nothing may be logged for this condition (system health is steady green, internal health is steady green, external health is steady green, power is steady green). Examine the iLO 2 MP logs for entries related to processors, processor power modules (PPMs), shared memory, and core I/O devices (see “Errors and Reading Error Logs” (page 119) for details).</p> <p><b>NOTE:</b> Be sure to check the console settings from the Boot Manager for your OS.</p> <p>The preceding problem is fixed when OS prompt appears on the system console.</p>

**Table 5-4 Advanced Low End Troubleshooting**

Step	Symptom/Condition	Action
6	Cannot read System Event Log from the system console.	<p>System event logging has stopped and a BMC malfunction is assumed (system health is steady green, internal health is steady green, external health is steady green, and power is steady green).</p> <ol style="list-style-type: none"> <li>1. Examine console messages for any EFI errors or warnings about BMC operation or communications.</li> <li>2. Examine the BMC heartbeat LED; if it is not flashing green, then replace the system board CRU (see “Management Subsystem” (page 133) for details).</li> <li>3. Test the operation of the BMC by toggling the UID locator switch LED on the front panel -- the blue LED is turned on/off by the BMC, when this switch is toggled</li> </ol> <p>The preceding problem is fixed when the BMC heartbeat LED is flashing green, and the SEL resumes logging.</p>
7	OS is non-responsive (hung).	<p>Front panel LEDs indicate that the server power is turned on, and it is either booting or running the OS (system health is steady green, internal health is steady green, external health is steady green, and power is steady green). Nothing may be logged for this condition. 1. Use a paper</p>

**Table 5-4 Advanced Low End Troubleshooting** *(continued)*

Step	Symptom/Condition	Action
		clip, pencil, or pen to press the INIT button on the front panel to start a system initialization. 2. Reboot the OS and escalate. 3. Obtain the system hardware status dump for root cause analysis. 4. Examine the iLO 2 MP logs for entries related to processors, processor power modules (PPMs), shared memory, and core I/O devices (see “Errors and Reading Error Logs” (page 119) for details).  The preceding problem is fixed when the root cause has been determined.
8a	MCA occurs during server operation; the server reboots the OS. (NOTE: Server reboots OS, if enabled)	Front panel LEDs indicate that the server detected a fatal error that it cannot recover from through OS recovery routines (system health is flashing red, internal health is steady green, external health is steady green, and power is steady green). 1. Capture the MCA dump with the EFI command, <code>errdump mca</code> . If the system can boot the OS, you can capture binary MCA dump files online. 2. Examine the iLO 2 MP logs for entries related to processors, processor power modules (PPMs), shared memory, and core I/O devices (See “Errors and Reading Error Logs” (page 119) for more details).  The preceding problem is fixed when the MCA does not repeat, or the source of the MCA has been determined and dealt with.
8b	MCA occurs during server operation; server reboot of OS is prevented. NOTE: The troubleshooting actions for this step are identical to those in Step 8a, except that the server in this step must be hard reset to begin the booting process. You must hard reset the server to clear the fatal condition and boot the OS	Front panel LEDs indicate that the server detected a fatal, front side bus error, caused by MBEs reading cache or DIMM; or by any parity in the I/O path between SBA, LBA, or HBA (system health is off, internal health is flashing amber, external health is steady green, power is steady green). System firmware is running to gather and log all error data for this MCA event. 1. Examine the iLO 2 MP logs for entries related to processors, processor power modules (PPMs), shared memory, and core I/O devices (See “Errors and Reading Error Logs” (page 119) for more details).  The preceding problem is fixed when the MCA does not repeat.

## Troubleshooting Tools

### LEDs

#### Front Panel

The front panel of the system contains the power button/system power LED, internal and external health LEDs, system health LED, locator switch/LED, and an INIT button. The rx2660 server use flashing states (for example, flashing amber or red) on these LEDs to indicate a warning or an error.

There are a total of three buttons, arranged horizontally, with the UID button and the power button each having an integrated LED. In addition to the two integrated button/LEDs, there are three health LEDs and an INIT button.

The health LEDs are arranged sequentially in line with the power button/LED, and as the system starts up, there will be more “green” the further the system proceeds in the startup process.

1. The power LED turns green soon as the system starts to power up.
2. The external health indicator turns green as soon as the BMC can light it.
3. The internal health indicator turns green as soon as the `BOOT_START` event is received from system firmware (`BOOT_START` can be determined by LED states on the I/O backplane).
4. The system health indicator turns green when firmware leaves “exit boot services” and begins to boot an OS.



The health LEDs are driven by the BMC; the power LED is driven solely by hardware. BMC code determines the state of the internal and external health LEDs, while the iLO 2 MP code, examining incoming events using its event dictionary, determines the state of the system health LED.

### External Health LED

The front panel external health LED indicates the status of the components that are externally serviceable. Whenever the external health LED is lit, the corresponding CRU should be lit for the failed component.

Failures that cause the external health LED to light do not cause the internal health LED to light. These two LEDs cover failures of different components.

**Table 5-5 External Health LED States**

Definition	Flash Rate	LED Color
Health good on all external CRUs and system power is off.	LED Off	Off
System power is on; externally serviceable components (usually accessible from front or back, such as fans and power supplies) are okay.	Steady	Green
An externally accessible CRU failed (system is on or in standby mode). Usually, this is a power supply or fan failure. Check front/back LEDs for failed component.	Flash 1 Hz	Amber

Amber supersedes green. This LED is cleared when all failed externally accessible entities are repaired and report that they are good, or on any ac/standby power cycle.

The iLO 2 MP displays the following strings in its Virtual Front Panel for the three states of this LED:

**Table 5-6 VFP External Health Description**

Off	<none>
On green	External parts, including fans and power supplies, okay
Flashing amber	A redundant, externally accessible CRU failed (check front/back LEDs)

### Internal Health LED

The front panel internal health LED indicates the status of the components internal to the system server. These components require the user to open the system in order to be serviced. This LED maintains its state when the system is in standby mode (system power turned off but ac power still applied to the system).

On larger Integrity servers that have a diagnostic LED board, this LED tells the service person to view that board for more information about the server failure. If the internal health LED is green, there is no fault information displayed on the diagnostic LED board, and no fault information displayed through LEDs that are inside the server.

The amber indicators on this LED must correspond to internal health conditions that light other LEDs in the box, indicating which component must be serviced to correct the fault. For example, the diagnostic LED board has a fault indicator lit when this LED is in the amber condition. Failures that cause the internal health LED to light do not cause the external health LED to light.

**Table 5-7 Internal Health LED States**

Definition	Flash Rate	LED Color
Health good on all internal CRUs and system off.	LED off	
Health good on all internal CRUs, and system firmware has passed "BOOT_START".	Steady	Green
An internally accessible CRU failed (system is on or in standby mode). Check the System Insight Display or internal system LEDs.	Flash 1 Hz	Amber

The internal health LED clears once all of the LEDs on the diagnostic LED panel have been cleared. For details on how each LED in the System Insight Display is cleared, see "System Insight Display LEDs" (page 115); also see the respective system specification for the server in question. Events that cause each internal CRU (or System Insight Display) LED to light are listed in the CRU section.

Amber supersedes green. This LED is cleared when all failed internally accessible entities are repaired and report that they are good, or on any ac/standby power cycle.



**NOTE:** The LEDs are cleared on the System Insight Display by turning off, not by turning green.

The iLO 2 MP displays the following strings in its Virtual Front Panel for the three states of this LED:

**Table 5-8 VFP Internal Health Description**

Off	<none>
On Green	Internal parts, including CPUs and memory, okay
Flashing Amber	An internally accessible CRU failed: check System Insight Display

### System Health LED

The rx2660 server has this LED for the following reasons:

- To carry forward the ATTENTION functionality of legacy Integrity and HP9000 front panel designs
- To give the customer an indication of whether the system is up or down (external and internal health LEDs do not tell the user if the system is booted.)
- To cover the wide range of faults for which software/firmware is not 100% sure that a CRU must be re-seated/replaced. (external and internal health LEDs do not light unless software/firmware can make a solid determination that a CRU must be re-seated/replaced.)

This LED indicates the overall health state of the system, including the state of system firmware and the OS. If the LED is amber or red, the system needs attention, and the event logs should be examined for details of the problem.

**Table 5-9 System Health LED States**

Definition	Flash Rate	LED Color
System is off, or system is booting firmware with no failures, since SEL logs last examined.	LED Off	
System has left the firmware boot, and an OS is booting or running with no failures, since SEL logs last examined.	Steady	Green
A warning or critical failure has been detected and logged.	Flash 1 Hz	Amber
A fatal fault has been detected and logged.	Flash 2 Hz	Red

The iLO 2 MP displays the following strings in its Virtual Front Panel for the four states of this LED:

**Table 5-10 VFP System Health Description**

Off	<none>
On green	OS booting or running
Flashing amber	Warning or critical fault: check logs for details
Flashing red	Fatal fault -- system crashed or cannot boot: check logs for details

#### Locator Switch/LED (Unit Identifier or UID)

The locator switch/LED allows a specific system to be identified in a rack or Data Center environment. One locator switch/LED is located in the front panel, and a second is located in the rear of the server. LEDs are incorporated inside the push-button to minimize space. Both switches are toggle switches, meaning you push it once to turn on the LED, and you push it again to turn off the LED. Pressing the front panel Switch/LED, or entering the iLO 2 MP and LOC commands, lights the rear panel LED, and vice versa.

- Off = Off
- Blue (Not flashing) = Identification

#### System Insight Display LEDs

The System Insight Display improves serviceability by allowing you to look in a single location for the LEDs that provide failing CRU locating/mapping information. These amber LEDs are only lit when a failure occurs; otherwise, they are off. The System Insight Display is located on the front panel of the server. A diagnostic LED exists for each CRU in the system, including all DIMMs. Figure 5-1 shows the System Insight Display LEDs.

**Figure 5-1 System Insight Display LEDs**



LED definitions are shown in Table 5-11:

**Table 5-11 System Insight Display LED States**

Definition	Flash Rate	LED Color
CRU health is assumed good.	LED Off	Off
CRU health last known to be bad.	Steady	Amber

## Field Replaceable Unit Health LEDs

In addition to the front panel diagnostic LEDs, CRUs provide additional diagnostic capability through LEDs, whose order or layout is product dependent.



---

**NOTE:** If multiple error conditions occur, all applicable CRU lights are activated. In such a case, the most critical error determines the front panel color.

---

## Diagnostics

A suite of offline and online support tools are available to enable manufacturing, field support personnel, and the customer to troubleshoot system problems. In general, if the operating system (OS) is already running, it is not desirable to shut it down, and the online support tools should be used.

If the OS cannot be booted, then the offline support tools should be used to help resolve the problem. The offline support tools are available either from the EFI partition, or from the IPF Offline Diagnostics and Utilities CD (IPF systems only). Once the problem preventing booting has been resolved, the OS should be booted, and the online support tools should be used for any further testing.

If it is not possible to reach EFI from either the main disk or from a CD, you must troubleshoot, using the visual fault indicators, console messages, and system error logs that are available.

## Online Diagnostics/Exercisers

Online support tools are available which permit centralized error archiving, and which provide hardware inventory tools, as long as the agents/providers that support them are installed on the managed server.

On HP-UX systems, the legacy tools within OnlineDiag are supported. The online support tools, on the HP-UX 11.23 and greater operating systems, include the Support Tool Manager (STM) tools, and the additional Web-Based Enterprise Management (WBEM) features added by SysFaultMgmt.

The STM suite of tools includes verifiers, diagnostics, exercisers, information modules, and expert tools.

Verifiers quickly determine whether or not a specific device is operational by performing tasks similar in nature to the way applications use the device. No license is required to run the verifiers.

Diagnostics are tools designed to identify faulty or failed CRUs.

Exercisers stress devices in order to facilitate the reproduction of intermittent problems.

Information modules create a log of information specific to one device, including:

- The product identifier
- A description of the device
- The hardware path to the device
- The vendor
- Onboard log information (if applicable)
- Miscellaneous information associated with the device
- The firmware revision code, if firmware is present in the device, is also displayed

Expert tools are device-specific troubleshooting utilities for use by sophisticated users. Their functionality varies from tool to tool, but they are intended to be interactive, and rely on users to provide information necessary to perform a particular task. These tools require users to have the appropriate license, if they wish to run them.

## Online Support Tool Availability

Online diagnostics are included in the HP-UX OE media, and are installed by default.

## Online Support Tools List

The following online support tools are available on HP-UX 11.23 hosted systems. In some cases, a tool, such as a disk exerciser, is generic to many types of hardware; in other cases, a tool, such as a tape diagnostic, is specific to a particular technology or type of tape drive.

**Table 5-12 Online Support Tools List**

Functional Area	Information	Verify	Exercise	Diagnose	Expert
System	Yes	No	No	No	No
CPU/FPU	No	No	Yes	No	Yes
Memory	Yes	No	Yes	No	No
Graphics	Yes	Yes	Yes	No	No
Core I/O LAN	Yes	Yes	Yes	Yes	No
Disk/Arrays	Yes	Yes	Yes	No	No
Tape	Yes	Yes	Yes	Yes	Yes
M/O	Yes	No	No	No	Yes
Add-On Network I/O Cards	Yes	Yes	Yes	No	Yes
Add-On Mass Storage I/O Cards	Yes	No	No	No	No

## Linux Online Support Tools

Online support tools are provided through Insight Manager (IM7) on Linux hosted systems. The exact coverage of these tools is the same as for the current IA-32 implementation. The IPF version of Insight Manager (IM7) has been re-architected to take advantage of current standards; for example, WBEM, WMI, CDM, CIM, XML.

## Offline Support Tools List

The following offline support tools are available:

**Table 5-13 Offline Support Tools List**

Offline Tool	Functional Area
CPUDIAG	Processor Diagnostic
MEMDIAG	Memory Diagnostic
MAPPER	System Mapping Utility
TITANDIAG	SBA/LBA Chipset
PERFVER	Peripheral Verifier
DFDUTIL	SAS/SCSI Disk Firmware Update Utility
DISKUTIL	Disk Test Utility (Non-Destructive)
COPYUTIL	Data Copy Utility
DISKEXPT	Disk Expert Utility
IODIAG	I/O Diagnostics Launch Facility (Executes third party diagnostics and runs BIST, if available)
CIODIAG2	Core I/O Diagnostic
Specific card I/O diagnostics	Card-Specific I/O Diagnostics/BIST

## General Diagnostic Tools

The following tools are currently available for support on other HP 9000 and Integrity server platforms. The distribution method is through the web.

**Table 5-14 General Diagnostic Tools List**

Diagnostic Tool	Description
IPMI Event Decoder	Provides detailed information about the IPMI event (Problem description, cause, action)
System Event Analyzer (SEA)	Program which automatically analyzes system error logs and IPMI SEL events. Produces Callout reports and CRU information (see <a href="http://h18023.www1.hp.com/support/svctools/webes">http://h18023.www1.hp.com/support/svctools/webes</a> for more information about this tool).
MCA Analyzer	Program that assists in the evaluation of an MCA or HPMC. Available as both a standalone, PC-based program, and as a monitor.

## Fault Management Overview

The goal of fault management and monitoring is to increase system availability, by moving from a reactive fault detection, diagnosis, and repair strategy to a proactive fault detection, diagnosis, and repair strategy. The objectives are as follows:

- To detect problems automatically, as nearly as possible to when they actually occur.
- To diagnose problems automatically, at the time of detection.
- To automatically report in understandable text a description of the problem, the likely cause(s) of the problem, the recommended action(s) to resolve the problem, and detailed information about the problem.
- To ensure that tools are available to repair or recover from the fault.

## HP-UX Fault Management

Proactive fault prediction and notification is provided on HP-UX by SysFaultMgmt WBEM indication providers, as well as by the Event Management System (EMS). The Event Management Service and WBEM provide frameworks for monitoring and reporting events.

SysFaultMgmt WBEM indication providers and the EMS Hardware Monitors allow users to monitor the operation of a wide variety of hardware products, and alert them immediately if any failure or other unusual event occurs. By using hardware event monitoring, users can virtually eliminate undetected hardware failures that could interrupt system operation or cause data loss.

Complete information on installing and using EMS hardware event monitors, as well as a list of supported hardware, can be found in the *EMS Hardware Monitors Users Guide*. An electronic copy of this book is provided on the HP website <http://docs.hp.com/hpux/diag>.

## WBEM Indication Providers and EMS Hardware Monitors

Hardware monitors are available to monitor the following components (These monitors are distributed free on the OE media):

- Server/fans/environment
- CPU monitor
- UPS monitor\*
- FC hub monitor\*
- FC switch monitor\*
- Memory monitor
- Core electronics components
- Disk drives
- Ha\_disk\_array



---

**NOTE:** No SysFaultMgmt WBEM indication provider is currently available for components followed by an asterisk.

---

## EMS High Availability Monitors

High Availability (HA) monitors are also available through EMS to monitor disk, cluster, network, and system resources. These tools are available from HP at an additional cost.

## Errors and Reading Error Logs

### Event Log Definitions

Often the underlying root cause of an MCA event is captured by system or BMC firmware in both the System Event and Forward Progress Event Logs (SEL and FP, respectively). These errors are easily matched with MCA events by their timestamps. For example, the loss of a CPU VRM might cause a CPU fault. Decoding the MCA error logs would only identify the failed CPU as the most likely faulty CRU. Following are some important points to remember about events and event logs:

- Event logs are the equivalent of the old server logs for status or error information output.
- Symbolic names are used in the source code; for example, MC\_CACHE\_CHECK.
- The hex code for each event log is 128 bits long with an architected format:
  - Some enumerated fields can be mapped to defined text strings.
  - All can be displayed in hex, keyword, or text mode.
- Events are created by firmware or OS code, and are sent over the PDH bus to the BMC for storage in either or both of the SEL and FP logs (HP-UX shows an I/O path for the BMC).
- The iLO 2 MP can display event logs: SEL events are sent over the IPMB, between the BMC and the iLO 2 MP.
- Event logs can also be read back over the PDH bus by software (for example, the IPMI driver or agent) for storage on disk.

### Using Event Logs

To consult the event logs:

1. Connect to the system console.
2. Use **Ctrl-B** to access the iLO 2 MP menu.
3. Use the `s1` command to view event logs: System Event (E) and Forward Progress (F) logs are very useful in determining the context of an error (See the following figure for an example):



**NOTE:** Remember that:

- E shows only event logs for Warning, Critical, or Fatal faults by default; F shows all event log outputs.
- System Event Logs (SELs) are never overwritten, unless they are first manually cleared: since they employ ring buffering, oldest logs get overwritten first. Forward Progress Logs (FPL) are circular and contain additional, non-critical information.
- The alert threshold can be changed.

## iLO 2 MP Event Logs

The iLO 2 MP provides diagnostic and configuration capabilities. See the *HP Integrity Integrated Lights-Out 2 Management Processor Operations Guide* for details on the iLO 2 MP commands. To access the iLO 2 MP, do the following:



**NOTE:** The iLO 2 MP must be accessed from a terminal console which has access to the iLO 2 MP.

1. Login with proper username and password.



**NOTE:** Default operator login and password: login = **oper**, password = **oper**.

2. Press `c1` to display the console history log. This log displays console history from oldest to newest.
3. Press `s1` to display the status logs. The status logs consist of:
  - System Event
  - Forward Progress
  - Current Boot
  - Previous Boot
  - Live Events
  - Clear SEL/FPL Logs
4. For a more information on configuring the iLO 2 MP and using the iLO 2 MP commands, see the *HP Integrity iLO 2 MP Operations Guides*.

## System Event Log (SEL) Review

1. Access the main menu under the iLO 2 MP command prompt (entering `cm` brings you to the command menu).
2. Run the `s1` command. The Event Log Viewer menu displays:

```
SL
Event Log Viewer:

Log Name                Entries    % Full    Latest Entry
-----
E - System Event        9          1 %      29 Oct 2002 19:15:05
F - Forward Progress    129        3 %
B - Current Boot        82
P - Previous Boot       0
C - Clear All Logs
L - Live Events
```

Enter menu item or [Ctrl-B] to Quit:

3. Select **e** to review the system events. The Event Log Navigation menu displays:

Enter menu item or [Ctrl-B] to Quit: e



Log Name	Entries	% Full	Latest Timestamped Entry
E - System Event	12	1 %	31 Oct 2003 23:37:45

Event Log Navigation Help:

```

+      View next block      (forward in time, e.g. from 3 to 4)
-      View previous block  (backward in time, e.g. from 3 to 2)
<CR>   Continue to the next or previous block
D      Dump the entire log
F      First entry
L      Last entry
J      Jump to entry number
H      View mode configuration - Hex
K      View mode configuration - Keyword
T      View mode configuration - Text
A      Alert Level Filter options
U      Alert Level Unfiltered
?      Display this Help menu
Q      Quit and return to the Event Log Viewer Menu
Ctrl-B Exit command, and return to the MP Main Menu

```

MP:SL (+,-,<CR>,D, F, L, J, H, K, T, A, U, ? for Help, Q or Ctrl-B to Quit) >a

Alert Level Threshold Filter:

```

1 : Major Forward Progress
2 : Informational
3 : Warning
5 : Critical
7 : Fatal

```

Enter alert level threshold or [Q] to quit filter setup: 3

-> Alert threshold level 3 filter will be applied.

Set up alert filter options on this buffer? (Y/[N])

Log Name	Entries	% Full	Latest Entry
E - System Event	410	47 %	18 Feb 2003 09:38:10

Event Log Navigation Help:

```

+      View next block      (forward in time, e.g. from 3 to 4)
-      View previous block  (backward in time, e.g. from 3 to 2)
<CR>   Continue to the next or previous block
D      Dump the entire log for capture and analysis
F      First entry
L      Last entry
J      Jump to entry number
V      View mode configuration (text, keyword, hex)
?      Display this Help menu
Ctrl-B Quit and return to the Main Menu

```

4. Select **A**, then a threshold filter number to filter events to desired level.

MP:SL (+,-,<CR>,D, F, L, J, H, K, T, A, U, ? for Help, Q or Ctrl-B to Quit) >a

Alert Level Threshold Filter:

```

1 : Major Forward Progress
2 : Informational
3 : Warning
5 : Critical
7 : Fatal

```

Enter alert level threshold or [Q] to quit filter setup: 3

-> Alert threshold level 3 filter will be applied.

5. Select **t** to change the display to text mode:

```
Display Mode Configuration:
      H - Hex mode
      Current -> K - Keyword mode
      T - Text mode
Enter new value, or [Q] to Quit:
```

6. To decode the blinking state of system LED, review the entire SEL and look at events with alert level 3 and above.

For example:

```
Log Entry 14: 01 Jan 1998 00:09:19
Alert Level 3: Warning
Keyword: EFI_SYSID_BMC_READ_ERROR
Cannot read a system ID
Logged by: System Firmware 0
Data: Status return from PDC function call
0x778002EF00E00150 0000000000000013
```

```
Log Entry 11: 01 Jan 1998 00:00:48
Alert Level 3: Warning
Keyword: EFI_SYSID_BMC_READ_ERROR
Cannot read a system ID
Logged by: System Firmware 0
Data: Status return from PDC function call
0x778002EF00E00100 0000000000000013
```

```
Log Entry 7: 23 Jun 2006 13:40:06
Alert Level 3: Warning
Keyword: PDH_INVALID_RTC_CLEARED
The RTC was found to be invalid and has been cleared
Logged by: System Firmware 0
Data: Data field unused
0x60800F8D00E00090 0000000000000000
```

```
Log Entry 4: 23 Jun 2006 13:39:35
Alert Level 3: Warning
Keyword: COOLING_UNIT_WARNING
Cooling unit warning
Logged by: Baseboard Management Controller;
Sensor: Cooling Device - Fan 11 (I/O)
Data1: transition to Non-Critical from OK
0x20449BEF17020050 FFFF01072B0A0300
```



**NOTE:** Due to the type of server you purchased, your output may not exactly match the output shown here.

---

## Supported Configurations

This subsection provides a system build-up procedure.

## System Block Diagram

The following is a system block diagram, showing the major rx2660 server functional components and their interconnections:

There are two types of CRUs in the rx2660 server:

- 1) externally accessible CRUs (eCRUs)
- 2) internally accessible CRUs (iCRUs).

In the following two lists, asterisks identify those CRUs identifiable by System Insight Display LEDs when they are faulty or have failed.

The following is a list of all eCRUs in the rx2660 server (see [Appendix A \(page 200\)](#) for CRU part numbers):

- \*Power supply (1 and 2)
- Console device
- Power cords
- \* SAS DVD and 2.5 HDDs

The following is a list of all the iCRUs in the rx2660 server:

- \*System board
- \*I/O board assembly
- SAS disk board
- \*CPUs
- \*DIMMs
- Diagnostic LED board
- \*Cooling Fans (1-12 for Data Center; 1-6 for Office Friendly)



**NOTE:** Items preceded by an asterisk in the lists above have associated diagnostic LEDs, which indicate device fault or failure.

---

## System Build-Up Troubleshooting Procedure

Use this procedure only when the system powers on and remain powered on but does not enter into or pass POST or does not boot to the EFI menu.

1. Remove the ac power cord from each power supply and extend the server, if racked.
2. Remove all of the SAS disk drives from the front of the server.
3. Remove the top cover to gain access to, and remove, everything but the I/O backplane and system board CRUs.



**NOTE:** In the following steps, CRU and FRU are used interchangeably.

---

4. Plug in the ac power cord(s) and the iLO 2 MP and system console should display and you should have the following CRU IDs listed after executing the MP DF command. Your display may not exactly match the display shown:

FRU IDs:  
-----

```
02-Power Converter 03-Power Supply 0 04-Power Supply 1  
05-Diagnostic Panel 06-Front Panel 00-Motherboard
```

If you do not see all of the above CRU IDs then concentrate on the missing CRU ID(S). You should eventually end up with the following Alert (IPMI) event for this action as read from the SEL. Your display may not exactly match the display shown:

```
Log Entry 4: Dec 2005 00:00:09
```

```
Alert Level 5: Critical  
Keyword: Type-02 257100 2453760  
Missing FRU device - Memory  
Logged by: Baseboard Management Controller,  
Sensor: Entity Presence  
0x2000000009020050 FF01807115250300
```

If you do not get the above Alert Level 5 (IPMI) event, but get another sort of high level alert, try replacing the I/O backplane. Then, examine the pins on the midplane board, and if necessary, replace the midplane board.

5. The next step would be to add one pair of DIMMs. Remember to remove the ac power cord(s) before making this configuration change.

Here is the output of the MP DF command you should expect at this point (this example has two ranks of DIMMs installed). Your display may not exactly match the display shown:

```
FRU IDs:  
-----
```

```
0152-DIMM0D 0001-Memory 0002-Power Converter  
0003-Power Supply 0 0004-Power Supply 1 0005-Diagnostic Panel  
0006-Front Panel 0128-DIMM0A 0136-DIMM0B  
0144-DIMM0C 0160-DIMM1A 0168-DIMM1B  
0176-DIMM1C 0184-DIMM1D 0000-Motherboard
```

If you do not see all of the above CRU IDs then concentrate on the missing CRU ID(s). You should eventually end up with the following Alert (IPMI) event for this action as read from the SEL. Your display may not exactly match the display shown:

```
Log Entry 3: Dec 2005 21:50:43
```

```
Alert Level 5: Critical  
Keyword: Type-02 257100 2453760  
Missing FRU device - CPU 0 PIROM  
Logged by: Baseboard Management Controller,  
Sensor: Entity Presence  
0x2041CB3DB3020040 FF20807115250300
```

If you do show the Alert level 5 “Missing CRU device - CPU 0 PIROM” then continue to the next step.

6. Insert the CPU board CRU with at least CPU 0 processor installed. When you add the CPU board CRU and turn on system power, the cooling fans should turn on and stay on and the DF command output should look something like the following. Your display may not exactly match the display shown:

```
FRU IDs  
-----
```

```
0001-Memory 0002-Power Converter 0003-Power Supply 0  
0004-Power Supply 1 0005-Diagnostic Panel 0006 Front Panel  
0007-Disk Management 0008-Disk backplane 0010-Processor Board  
0012-Power Pod 0 0013-Power Pod 1 0032-CPU 0 PIROM  
0033-CPU 1 PIROM 0036-Processor 0 RAM 0037-Processor 1 RAM  
0128-DIMM0A 0136-DIMM0B 0144-DIMM0C  
0152-DIMM0D 0160-DIMM1A 0168-DIMM1B  
0176-DIMM1C 0184-DIMM1D 0000-Motherboard
```

If the installed CRUs are all functional then the system should initiate POST on all processors. It is recommended to observe the system console output through “Live Logs” to ensure that POST is initiated and completes without error.

If power-on-self-test (POST) does not start after a few seconds then suspect some sort of system board or processor problem. Typical problems show up in the SEL or FWP. If the IMPI event logs do not point to a root cause, then escalate to bring in expert assistance.

## CPU/Memory/SBA

All of the CPU, Memory controller, and System Bus Adapter (SBA or I/O rope controller) functions reside on the system board; DIMMs reside on the system board; and the Local Bus Adapter (LBAs or PCI-X bus controller chips) reside on the I/O Backplane and the system board along with customer Host Bus Adapter (HBA device controller) I/O cards. This section discusses the roles of logical CPUs, physical memory ranks, and the rope interfaces in the SBA logic of the zx2 chip.

## Troubleshooting rx2660 CPU

The rx2660 server supports both single- and dual-core processors. Each rx2660 server supports one or two IPF processor modules. The dual-core processor modules contain two individual CPU cores. This results in four physical CPUs when two processor modules are installed in rx2660 servers.

Furthermore, unlike previous IPF processor modules, each physical CPU core contains logic to support two physical threads. This results in up to eight physical threads, or the equivalent of eight logical CPUs, when two dual-core processor modules are installed and enabled in rx2660 servers (the operating system kernel attaches one or more software processes to each available thread, so in multiple processor servers, having more threads means all software processes are launched and executed faster).

### IPF Processor Load Order

For a minimally loaded server, one IPF processor module must be installed in CPU slot 0 on the system board, and its threads must be enabled by user actions. Additional processor modules of the same revision are installed in CPU slot 1 for rx2660 servers.

### Processor Module Behaviors

All enabled CPUs and their threads almost immediately become functional after system power is applied. Each thread is in a race to fetch their instructions from their CPU instruction and data caches to complete early self test and rendezvous.

Early code fetches come from PDH, until memory is configured. Then normal execution is fetched from main memory.

Local MCA events cause the physical CPU core and one or both of its logical CPUs within that IPF processor module to fail while all other physical and their logical CPUs continue operating. Double-bit data cache errors in any physical CPU core causes a Global MCA event that causes all logical and physical CPUs in the server to fail and reboot the operating system.

### Customer Messaging Policy

- A diagnostic LED only lights for physical CPU core errors, when isolation is to a specific IPF processor module. If there is any uncertainty about a specific CPU, then the customer is pointed to the SEL for any action, and the suspect IPF processor module CRU LED on the System Insight Display is not lighted.
- For configuration style errors, for example, when there is no IPF processor module installed in CPU slot 0, all of the CRU LEDs on the diagnostic LED panel are lighted for all of the IPF processor modules that are missing.
- No diagnostic messages are reported for single-bit errors that are corrected in both instruction and data caches, during corrected machine check (CMC) events to any physical CPU core. Diagnostic messages are reported for CMC events when thresholds are exceeded for single-bit errors; fatal processor errors cause global / local MCA events.

**Table 5-15 Processor Events That Light System Insight Display LEDs**

Diagnostic LED(s)	Sample IPMI Events	Cause	Source	Notes
Processors	Type E0h, 39d:04d BOOT_DECONFIG_CPU	Processor failed and deconfigured	SFW	This event follows other failed processor(s)
Processors	Type E0h, 5823d:26d PFM_CACHE_ERR_PROC	Too many cache errors detected by processor	WIN Agent	Threshold exceeded for cache parity errors on processor

**Table 5-15 Processor Events That Light System Insight Display LEDs** *(continued)*

Diagnostic LED(s)	Sample IPMI Events	Cause	Source	Notes
Processors	Type E0h, 5824d:26d PFM_CORR_ERROR_MEM	Too many corrected errors detected by platform	WIN Agent	Threshold exceeded for cache errors from processor corrected by zx2
Processors	Type 02h, 02h:07h:03h VOLTAGE_DEGRADES_TO_NON_RECOVERABLE	Voltage on CRU is inadequate	BMC	Power Pod voltage is out of range (likely too low)

**Table 5-16 Processor Events That May Light System Insight Display LEDs**

Diagnostic LED(s)	Sample IPMI Events	Cause	Source	Notes
Processors	Type E0h, 734d:26d BOOT_CPU_LOADING_ERROR	Installed processors are not compatible	SFW	
Processors	Type E0h, 2953d:26d BOOT_CPU_LOADING_ERROR	Processors and/or termination out of order	SFW	
Processors	Type E0h, 36d:26d BOOT_CPU_LATE_TEST_FAIL	A logical CPU (thread) failed late self test	SFW	
Processors	Type E0h, 677d:26d MC_RENDEZVOUS_SLAVES_FAIL	A logical CPU (thread) slave failed to rendezvous	SFW	
Processors	Type E0h, 30d:26d BOOT_CPU_CONFIG_FAIL	A CPU core failed the configuration process	SFW	
Processor	Type E0h, 790d:26d BOOT_CPU_BAD_CORE_FIXED_RATIO	A processor fixed core frequency ratio is incompatible with bus frequency	SFW	
Processor	Type E0h, 745d:26d BOOT_FINAL_RENDEZ_WATCHDOG_FAIL	A watchdog timer expired and determined that a monarch processor is not responding.	SFW	
Processors	Type E0h, 83d:26d BOOT_RENDEZ_FAILURE	A logical CPU (thread) rendezvous failure	SFW	Bad or slow processor
Processors	Type E0h, 67d:26d BOOT_MONARCH_TIMEOUT	The logical monarch CPU	SFW	

**Table 5-16 Processor Events That May Light System Insight Display LEDs** *(continued)*

Diagnostic LED(s)	Sample IPMI Events	Cause	Source	Notes
		(thread) has timed out		
Processors	Type E0h, 57d:26d BOOT_INCOMPATIBLE_SLAVE	A logical slave CPU (thread) is incompatible with logical monarch CPU	SFW	
Processor	Type E0h, 56d:26d BOOT_INCOMPATIBLE_PAL	CPU PAL incompatible with processor	SFW	
Processors	Type E0h, 34d:26d BOOT_CPU_FAILED	A processor failed	SFW	
Processors	Type E0h, 33d:26d BOOT_CPU_EARLY_TEST_FAIL	A logical CPU (thread) failed early self test	SFW	
Processors	Type 02h, 25h:71h:80h MISSING_FRU_DEVICE	No physical CPU cores present	BMC	Possible seating or failed processor

## Troubleshooting rx2660 Memory

The memory controller logic in the zx2 chip supports the eight slots for rx2660 servers. It provides two physical ranks that hold two or four DIMMs in memory cells 0 and 1.

### Memory DIMM Load Order

For a minimally loaded server, two equal-size DIMMs must be installed in slots 0A and 0B in the DIMM slots on the system board. The DIMM load order of pairs is as follows; slots 0A and 0B, then slots 1A and 1B, then 2A and 2B, then 3A and 3B.

### Memory Subsystem Behaviors

The zx2 chip in the rx2660 server provides increased reliability of DIMMs. For example, previous low end servers with zx1 chips provided error detection and correction of all memory DIMM single-bit errors and error detection of most multi-bit errors within a memory DIMM pair, or 4 bits per rank (this feature is called chip sparing).

The zx2 chip doubles memory rank error correction from 4 bytes to 8 bytes of a 128 byte cache line, during cache line misses initiated by processor cache controllers and by Direct Memory Access (DMA) operations initiated by I/O devices. This feature is called double DRAM sparing, as 2 of 72 DRAMs in any DIMM pair can fail without any loss of server performance.

Corrective action, DIMM/memory expander replacement, is required when a threshold is reached for multiple double-byte errors from one or more DIMMs in the same rank. And when any uncorrectable memory error (more than 2 bytes) or when no pair of like DIMMs is loaded in rank 0 of side 0. All other causes of memory DIMM errors are corrected by zx2 and reported to the Page Deallocation Table (PDT) / diagnostic LED panel.

## Customer Messaging Policy

- Only light a diagnostic LED for memory DIMM errors when isolation is to a specific memory DIMM. If any uncertainty about a specific DIMM, then point customer to the SEL for any action and do not light the suspect DIMM CRU LED on the System Insight Display.
- For configuration style errors, for example, no DIMMs installed in 0A and 0B, follow the HP ProLiant policy of lighting all of the CRU LEDs on the diagnostic LED panel for all of the DIMMs that are missing.
- No diagnostic messages are reported for single-byte errors that are corrected in both zx2 caches and DIMMs during corrected platform error (CPE) events. Diagnostic messages are reported for CPE events when thresholds are exceeded for both single-byte and double byte errors; all fatal memory subsystem errors cause global MCA events.
- PDT logs for all double byte errors are permanent; single byte errors are initially logged as transient errors. If the server logs 2 single byte errors within 24 hours, then upgrade them to permanent in the PDT.

**Table 5-17 Memory Subsystem Events That Light System Insight Display LEDs**

Diagnostic LED(s)	Sample IPMI Events	Cause	Source	Notes
DIMMs	Type E0h, 208d:04d MEM_NO_DIMMS_INSTALLED	No DIMMs installed (in rank 0 of cell 0)	SFW	Light all DIMM LEDs in rank 0 of cell 0
DIMMs	Type E0h, 172d:04d MEM_DIMM_SPD_CHECKSUM	A DIMM has a serial presence detect (SPD) EEPROM with a bad checksum	SFW	Either EEPROM is misprogrammed or this DIMM is incompatible
DIMMs	Type E0h, 4652d:26d WIN_AGT_PREDICT_MEM_FAIL	This memory rank is correcting too many single-bit errors	WIN Agent	Memory rank is about to fail or environmental conditions are causing more errors than usual

**Table 5-18 Memory Subsystem Events That May Light System Insight Display LEDs**

Diagnostic LED(s)	Sample IPMI Events	Cause	Source	Notes
DIMMs	Type E0h, 4000d:26d MEM_CHIPSPARE_DEALLOC_RANK	Detected that an SDRAM is failing on the DIMM	SFW	The failing DIMM rank is deallocated
DIMMs	Type E0h, 174d:26d MEM_DIMM_TYPE_INCOMPATIBLE	DIMM type is not compatible with current DIMMs for this platform	SFW	
DIMMs	Type E0h, 173d:26d MEM_DIMM_SPD_FATAL	Detected a fatal error in DIMM serial presence detect (SPD)	SFW	

## Troubleshooting rx2660 SBA

The rx2660 server shares a common I/O backplane that supports a total of three PCIe/PCI-X slots. The System Bus Adapter (SBA) logic within the zx2 chip of a rx2660 server uses 16 rope interfaces to support up to eight Lower Bus Adapter (LBA) chips. Each LBA chip interfaces with the SBA in the zx2 chip through one or multiple rope interfaces, as follows.



For the PCI-X I/O backplane:

- Two LBA chips use two dual-rope (4 ropes total) interfaces to support two single 64-bit PCI-X slots running @ 133 MHz
- One LBA chip uses one quad-rope interface to support one single 64-bit PCI-X slot running @ 266 MHz

For the PCI-X/PCIe backplane:

- One LBA chip uses one dual-rope interface to support one single 64-bit PCI-X slot running @ 133 MHz
- Two LBA chips use two quad-rope (8 ropes total) interfaces (for customer use) to support two PCI express x8 slots

## Power Subsystem

The two power supply CRUs for the rx2660 server provides N+1 redundancy for the server. Each power supply CRU is identified by the server as 1 and 2 for logging purposes. There are corresponding LEDs on the diagnostic LED panel for the power supplies.

Power supply CRU failures are identified visually by a single green LED that is turned off when one or both of the power supplies fail; logged as an IPMI event by voltage sensor logic; and identified as a power supply CRU failure by the BMC turning on the appropriate LEDs on the front LED panel.

## Power Subsystem Behavior

For rx2660 servers, each bulk power supply CRU provides 900 watts of dc power from a nominal 120 VAC, 50-60 Hz; and 1000 watts from a nominal 240 VAC, 50-60 Hz. The BMC chip located on the system board controls the flow of +12 VDC power to the server CRUs. You can control and display power supply status remotely with the iLO MP `pc` and `ps` commands, respectively.

Typical power up sequence of the server is as follows:

- Power LED on front panel glows steady amber when one or two bulk power supplies are plugged into nominal ac voltage and the +3.3 VDC housekeeping voltage comes on and stays on whenever ac power is present.
- The BMC, iLO 2 MP, Flash memory, and server intrusion circuits are reset after the +3.3 VDC housekeeping voltage stabilizes.
- The BMC monitors the power button on the front panel.
- When the power button is pressed, the BMC signals the bulk power supplies to fully power up.
- +12 VDC comes up and all of the cooling fans and the various VRMs come up sequentially.
- The BMC signals when the server is ready to come out of reset (clocks are programmed and stable, etc.).
- The server is brought out of reset.
- The zx2 chip resets all components connected and the server begins the boot process.

## Power LED/Switch

The front panel system power LED indicates the status of system power. It is incorporated inside the power button itself.

The power button has a momentary switch (as opposed to a latching switch) that is recessed or covered to prevent accidental activation or de-activation.

If the OS is up, pressing the power button for less than four seconds results in a graceful shutdown of the operating system and a subsequent removal of system power. Pressing the power button for greater than four seconds results in a hard shutdown (system power removed). While the server is booting (before the system has passed `EFI_EXIT_BOOT_SERVICES`), the BMC

immediately powers the server off on a button press, since there is no concept of soft shutdown in this state.

In the event that the OS is absent or hung, or that the manageability subsystem (specifically the BMC) in the server is not responding, a greater than four second press of the power button is required to power down the system (a less than four second press on the power button has no effect).

To ensure that the system powers up in a deterministic fashion, the power button must be masked for four seconds after a power-down.

**Table 5-19 Power LED States**

Definition	Flash Rate	LED Color
No ac power to the system	LED Off	
System power is turned on	Steady	Green
System is shut down, but ac and housekeeping (standby) power are active.	Steady	Amber

For high availability and safety reasons, this LED runs off the power rails, rather than under firmware control.

## Cooling Subsystem

The three fan cooling zones located within the rx2660 server provide N+1 redundancy for the server using three identical dual fan assembly CRUs. In turn, each dual fan assembly CRU provides additional N+1 redundancy for the fan cooling zone it controls. Each dual fan assembly CRU is identified by the server as fans 1 through 12 both for logging purposes and for fault identification on the diagnostic LED panel.

External cooling fan CRU failures are identified visually by a single green LED on the dual fan assembly CRU that is turned on when one or both of the fans fail; logged as an IPMI event by fan sensor logic; and identified as a fan assembly CRU failure by the BMC turning on the appropriate LEDs on the System Insight Display panel.

## Cooling Subsystem Behavior

The BMC chip located on the system board CRU controls fan speed on ambient air temperatures, chip temperatures, server configuration, and fan operation or failure. Air is drawn through the front of the server and pushed out the rear by the cooling fans. There are three cooling zones cooled by the 12 server fans. Zone 1 is cooled by fans 1 through 4, zone 2 is cooled by fans 5 through 8, and zone 3 is cooled by fans 9 through 12. Each zone can have one fan failure and still sufficiently cool the server. You can display fan status remotely with the iLO 2 MP ps command.

Within the HP integrity rx2660 server, temperature sensors report server temperatures to the BMC, which controls fan speed based on this information.

**Table 5-20 Cooling Subsystem Events That Light System Insight Display LEDs**

Diagnostic LED(s)	Sample IPMI Events	Cause	Source	Notes
Fans (1-12)	Type 02h, 0Ah:07h:01h COOLING_UNIT_WARNING	Fan has either previously failed or is degrading	BMC	Cleared when fan is replaced
Fans (1-12)	Type 02h, 0Ah:07h:02h COOLING_UNIT_FAILURE	Fan has failed and no longer meets minimum requirements	BMC	Cleared when fan is replaced

## I/O Backplane (LBAs/Ropes/PDH/PCI-X/PCIe Slots)

This subsection provides information on troubleshooting issues with the three public PCI-X/PCIe slots.

### I/O Subsystem Behaviors

The main role of the I/O subsystem is to transfer blocks of data and instruction words between physical shared memory and virtual memory (system disks / disk array). The system boot is the first time blocks of data and instructions words are transferred into physical shared memory from a local disk / DVD or from a remote disk on another server through multiple LAN transfers. This process is referred to as Direct Memory Access (DMA) and is initiated by I/O devices located in I/O or on Host Bus Adapter (HBA) I/O cards and does not involve any logical CPUs.

A secondary role of the I/O subsystem is to transfer data between the internal registers within each CPU core and the internal control/store registers within the zx2 / PDH / Local Bus Adapters (LBA) and HBA chips. This process is referred to as programmed I/O and is initiated by logical CPUs executing external LOAD / STORE instructions. Both system firmware and OS kernel both use this method to initiate DMA transfers.

### Customer Messaging Policy

- Always refer to the SEL for any action from low level I/O subsystem faults as there may not be any lighted LEDs on the System Insight Display. IPMI events in SEL / FPL provide the logical ACPI path of suspect I/O subsystem CRU. Use Table 5-23 to determine the physical PCI slot number.
- For configuration style errors, for example, no iLO 2 MP / core I/O HBAs installed or working, see Supported Configurations subsection for actions.
- Some diagnostic messages are reported for high level I/O subsystem errors; all fatal I/O subsystem errors cause global MCAs. HP-UX provides its own path with the physical rope number of the suspect I/O subsystem CRU. Use Table 5-23 to determine the physical PCI slot number.

**Table 5-21 I/O Subsystem Events That Light System Insight Display LEDs**

Diagnostic LED(s)	Sample IPMI Events	Cause	Source	Notes
I/O Card	Type 02h, 03h:05h:01h CURRENT_LIMIT_EXCEEDED	Over-current on PCI slot	BMC	Likely a short on I/O card or I/O slot.
I/O Backplane	Type 02h, 02h:07h:03h VOLTAGE_DEGRADES_TO_NON_RECOVERABLE	Voltage on CRU is inadequate	BMC	A voltage on the I/O backplane is out of range (likely too low)
Disk Backplane	Type 02h, 02h:07h:03h VOLTAGE_DEGRADES_TO_NON_RECOVERABLE	Voltage on CRU is inadequate	BMC	A voltage on the I/O backplane is out of range (likely too low)

**Table 5-22 I/O Card Events That May Light System Insight Display LEDs**

Diagnostic LED(s)	Sample IPMI Events	Cause	Source	Notes
I/O Card	Type E0h, 4658d:26d IO_PCI_POWER_OVERLOAD_ERR	A non hot plug I/O slot power consumption increases the total I/O power consumption	SFW	Disallow O/S boot and display the following EFI error message, "I/O

**Table 5-22 I/O Card Events That May Light System Insight Display LEDs** *(continued)*

Diagnostic LED(s)	Sample IPMI Events	Cause	Source	Notes
		beyond the supported limit		configuration exceed"
I/O Card	Type E0h, 137d:26d IO_NOT_ENOUGH_POWER_ERROR	Insufficient power to power on a hot-plug PCI-X slot	SFW	Display EFI warning message "Failed I/O slot(s) deconfigured"
I/O Card	Type E0h, 147d:26d IO_SLOT_STANDBY_POWER_ERROR	PCI slot standby power failed	SFW	Either a card / slot problem. Re-seat card first.
I/O Card	Type E0h, 131d:26d IO_HOT_PLUG_CTRL_FAILED	PCI-X hot-plug controller failed	SFW	Either a card / slot problem. Re-seat card first.
I/O Card	Type E0h, 139d:26d IO_PCI_MAPPING_TOO_BIG	PCI bus walk (I/O discovery) resources exceeded	SFW	Remove any unsupported I/O cards. Move I/O card to an unused PCI slot
I/O Card	Type E0h, 148d:26d IO_UNKNOWN_PCIXCAP_VAL	Found invalid PCIXCAP value	SFW	
I/O Card	Type E0h, 141d:26d IO_PCIXCAP_SAMPLE_ERROR	PCIXCAP sampling error	SFW	
I/O Card	Type E0h, 123d:26d IO_CHECK_LBA_MISSING_ERR	Expected I/O host bridge (Lower Bus Adapter) is missing	SFW	
I/O Card	Type E0h, 619d:26d IO_CHECK_LBA_DECONFIG_ERR	Expected I/O host bridge (Lower Bus Adapter) is deconfigured	SFW	
I/O Card	Type E0h, 133d:26d IO_LBA_CLEAR_ERR_FAILED	I/O LBA clear error failed	SFW	
I/O Card	Type E0h, 144d:26d IO_SBA_CLEAR_ERR_FAILED	I/O SBA clear error failed	SFW	
I/O Card	Type E0h, 146d:26d IO_SLOT_POWER_ON_ERROR	PCI-X slot power on error	SFW	
I/O Card	Type E0h, 145d:26d IO_SLOT_POWER_DEFAULT_ERROR	PCI-X slot has incorrect default power state	SFW	
I/O Card	Type E0h, 136d:26d IO_LBA_RESET_ERROR	I/O host bridge (Lower Bus Adapter) is inaccessible because rope reset failed to complete	SFW	
I/O Card	Type E0h, 130d:26d IO_DLL_ERROR	PCI clock DLL error	SFW	
I/O Card	Type E0h, 143d:26d IO_ROPE_RESET_ERROR	I/O rope reset failed to complete	SFW	

**Table 5-22 I/O Card Events That May Light System Insight Display LEDs** (continued)

Diagnostic LED(s)	Sample IPMI Events	Cause	Source	Notes
I/O Card	Type E0h, 7346d CC_IODISC_LBA_LINK_TRAIN_ERR	PCIe link failed to train	SFW	
I/O Card	Type E0h, 7356d IO_PCIE_LINK_SUBOPTIMAL	PCIe link is not running at max capable bandwidth	SFW	

**Table 5-23 PCI-X Rope to ACPI Paths**

Physical Slot #	Physical Rope Number	Logical ACPI Path
1 - public PCI- X @ 266 MHz	12 - 15	Acpi(HWP0002,PNP0A03,700)/Pci(1 0)
2 - public PCI- X @ 133 MHz	10 - 11	Acpi(HWP0002,PNP0A03,600)/Pci(1 0)
3 - public PCI- X @ 266 MHz	4 - 7	Acpi(HWP0002,PNP0A03,300)/Pci(1 0)

**Table 5-24 PCIe/PCI-X Rope to ACPI Paths**

Physical Slot #	Physical Rope Number	Logical ACPI Path
1 - public PCI- e @ 333 MHz	12 - 15	Acpi(HPQ0002,PNP0A08,700)/Pci(0 0)
2 - public PCI- e @ 333 MHz	4 - 7	Acpi(HPQ0002,PNP0A08,300)/Pci(0 0)
3 - public PCI- X @ 133 MHz	10 - 11	Acpi(HWP0002,PNP0A03,600)/Pci(1 0)

## Management Subsystem

### iLO 2 MP LAN LED on the Rear Panel

The iLO 2 MP LAN supports two LEDs, viewable from the rear of the system:

1. iLO 2 MP LAN LED, which indicates link/activity status.
2. LAN LED, which shows the link speed. Only 10 Mb and 100 Mb speeds are currently supported on the iLO 2 MP LAN.

Table 5-25 lists the iLO 2 MP LAN link statuses with their corresponding LED states:

**Table 5-25 iLO 2 MP LAN LED States**

Link Status	LED State
Activity	Flashing green
Link with no activity	Steady green
No link	Off



**NOTE:** For information on the LAN LED, see “System LAN LEDs” (page 135).

### iLO 2 MP Status LEDs

There are four iLO 2 MP status LEDs on the rear panel of the server. They are as follows:

- iLO 2 MP heartbeat
- iLO 2 MP self-test
- BMC heartbeat
- Standby power

Table 5-26 lists the state of the iLO 2 MP status LEDs during normal operation.

**Table 5-26 iLO 2 MP Status LEDs**

iLO 2 MP Status LED	LED State
iLO 2 MP heartbeat	Flashing green
iLO 2 MP self-test	Off: The LED is solid amber when ac power is applied. It remains solid amber for a few seconds until the iLO 2 MP completes its self-test; then the LED turns off
BMC heartbeat	Flashing green
Standby power	Solid green

## Manageability Reset Button on System Board Bulkhead

The Manageability reset button, accessed from the rear of the server, allows you to reset the iLO 2 MP, it optionally also resets user-specified values to factory default values. A momentary press causes a soft reset of the iLO 2 MP, when the button is released. A greater than four-second press does the same, and also returns user-specified values to factory default values (hard reset).

The crucial values to be reset are as follows:

- Serial terminal baud settings
- User names and passwords

## Manageability Status LED

The manageability status LED indicates the state and health of the iLO 2 MP. It is visible from the rear of the server. The states are as follows:

**Table 5-27 Manageability Status LED**

LED State	Definition
Off	iLO 2 MP is not responding
Steady Amber	Self Test
0.5 Hz Flashing Green	Heartbeat
1 Hz Flashing Amber	ROM Error

## I/O Subsystem (SAS/DVD/HDD)

### Verifying SAS Disk Drive Operation

Each SAS disk drive has an activity LED indicator on the front of the drive.



**NOTE:** On the HP Integrity rx2660 server, only the activity LED is used. The status LED is not monitored by the OS.

Verify that the LED shows the correct activity indication for all disk drives that you installed:

1. Turn on power to the server and display monitor.

2. During the boot sequence, watch the activity LED on each SAS disk drive:
  - Activity LED: The LED quickly cycles from amber to green. The LED stays steady green until the drive spins up.
3. If the activity LED stays illuminated steady green on any SAS disk drives (after the drive spins up), the drive may not be seated correctly. Check installation as follows:
  - a. Turn off the server power button and unplug the ac power cords and any cables.
  - b. Re-seat all of the SAS disk drives installed in the server.
  - c. Reconnect the ac power cords and any cables. Restart the server to determine whether the LEDs now become illuminated during the boot. If not, contact your reseller.
4. Use the EFI Shell `info io` command to check the SCSI drives.

## System LAN LEDs

There are two system LAN LEDs on the rear bulkhead of the HP Integrity rx2660 server. These LANs are connected to the system board.

### System LAN LEDs

There are two 1 Gb LAN ports on the rear panel of the server. They are LAN 1 and LAN 2. Table 5-28 shows the Gb LAN 1 LEDs on the rear panel of the server.

**Table 5-28 Gb LAN 1 Connector LEDs**

LED	Description
Speed (left)	Yellow: the 1000 MHz with Ethernet protocol is enabled
	Green: the 100 MHz with Ethernet protocol is enabled
	Off: no link
Link (right)	Green: link
	Off: No link

Table 5-29 shows the 1 Gb LAN 2 LEDs on the rear panel of the server.

**Table 5-29 Gb LAN 2 Connector LEDs**

LED	Description
Speed (left)	Yellow: the 1000 MHz with Ethernet protocol is enabled
	Green: the 100 MHz with Ethernet protocol is enabled
	Off: no link
Link (right)	Green: link
	Off: No link

## Booting

Table 5-30 shows the normal boot process, as reflected in changes to front panel LED states:

**Table 5-30 Normal Boot Process LED States**

Step	System Health	Internal Health	External Health	Power	System Insight Display	Normal Power-Up Through OS Boot
1	Off	Off	Off	Off	Off	No ac power to the system.
2	Off	Off	Off	Steady amber	Off	System is shut down, but ac power and standby power is active.

**Table 5-30 Normal Boot Process LED States** (continued)

Step	System Health	Internal Health	External Health	Power	System Insight Display	Normal Power-Up Through OS Boot
3	Off	Off	Off	Steady green	Off	System power rails are on when power switch is toggled.
4	Off	Off	Steady green	Steady green	Off	System power rails are on; BMC drives external health LED.
5	Off	Steady green	Steady green	Steady green	Off	System is booting firmware (has passed <code>BOOT_START</code> in firmware).
6	Steady green	Steady green	Steady green	Steady green	Off	System has finished booting firmware and an OS is either booting or running.



**NOTE:** In the normal boot process, shown in the preceding table, even though the BMC is running while the system is shut down (power LED is steady amber), it doesn't drive the external health LED to steady green until +12 VDC power from the Bulk Power Supplies is applied.

The following list itemizes the steps that characterize basic platform boot flow. Step numbers provided correspond to the steps in the preceding table, Table 5-31, "Normal Boot Process LED States":

- 3) System power switch turns on bulk power supplies and fans, and releases RESET on all CPUs simultaneously, when toggled on.
- 5) Initial CPU firmware code fetch is PAL code from EEPROM in PDH, retrieved 4 bytes at a time by DMDC in zx2 (No shared memory or I/O devices are available at this time; for example they are not initially configured).
- 5) Firmware code stack is initially in BBRAM in PDH, retrieved 4 bytes at a time, through PDH and DMD buses.
- 5) PAL code configures all CPUs.
- 5) SAL code configures all platform zx2 chips, including shared memory and all responding I/O devices.
- 5) Firmware code and stack are relocated to shared memory, after all x4 DIMM ranks in shared memory are configured and tested.
- 5) EFI Shell is launched from shared memory, and cache lines are retrieved 128 bytes at a time by MEMC in zx2.
- 6) OS loader is launched using the EFI device driver.
- 6) OS boots and starts its own device drivers.
- 6) OS may use runtime PAL and SAL calls, and APCI features (these abstraction layers allow platform independence).

## Firmware

The system has three sets of firmware installed:

- System firmware
- BMC firmware
- iLO 2 MP firmware

All firmware (SFW, BMC, iLO 2 MP, etc.) must be from the same release. Independent updates are not supported. Details about a specific release are available in the associated Release Notes.

Firmware updates are available from <http://www.hp.com> under "Support and Drivers".



## Identifying and Troubleshooting Firmware Problems

Erratic system operation, or the fact that the server may not boot successfully to the EFI Boot Manager or to the EFI Shell, are symptoms of possible firmware problems.

It should be noted that problems due to firmware are relatively rare, and you should look for other problem causes first.

If you are dealing with a firmware problem, the probable failure areas are as follows:

- Unsupported firmware installation
- Corrupt firmware installation

To troubleshoot firmware problems:

1. Verify that all system and BMC firmware components are from the same release (use the `iLO 2 MPsr` command).
2. Reinstall all firmware.

## Updates

The firmware version 03.01 or later is current as of the release date of this guide. System firmware updates are available from the HP Business Support Center at:

<http://www.hp.com/go/bizsupport>.

To update your firmware, follow these steps:

1. Start up the system and go to the EFI command prompt.
2. To determine the current firmware version, run the EFI `info fw` command at the EFI Shell prompt.
3. Choose the appropriate firmware package from the choices available on the HP Support Center web page at <http://www.hp.com/go/bizsupport>. If a new version of the firmware is available, download it and save it to CD, or copy it over the network to the system you are updating.

## Server Interface (System Console)

All system console connections (VGA, USB, local RS-232 and iLO 2 MP LAN) are located on the rear panel of the rx2660 server.

HP-UX uses the RS-232 serial text connection to a (dumb) terminal or terminal emulator software running on a PC to control server operations locally.

HP-UX alternatively uses the iLO 2 MP LAN connection over a private network to control server operations locally through telnet or SSH, and remotely over a public network through web GUI.

Both the Windows and LINUX operating systems use the VGA (monitor) and USB (keyboard and mouse) connections to control server operations locally.

## Troubleshooting Tips

RS-232 connection: If a dumb terminal / PC running terminal emulation software is attached to the iLO 2 MP "local" port and does not respond to a **Ctrl-B-enter** key sequence (and the terminal is running 9600 baud, 8 data bits, is ONLINE, etc.) then it is possible that the iLO 2 MP is not operational / functional. See "Management Subsystem" (page 133) for the following LED locations:

- The iLO 2 MP heartbeat LED
- The BMC heartbeat LED

Replace system board CRU if both heartbeat LEDs are not flashing green; suspect bulk power supplies, or I/O backplane CRU if both heartbeat LEDs are off.

LAN connections: See "I/O Subsystem (SAS/DVD/HDD)" (page 134) for iLO 2 MP LAN LED states.

## Environment

Ambient intake air temperature is often different from ambient room temperature; you should measure the operating temperature and humidity directly in front of the cabinet cooling air intakes, rather than measure only ambient room conditions.

Within the server, temperature sensors report server temperature to the BMC. The BMC controls fan speed, based on this information.

Temperature sensors are found on:

- Display panel, where a thermal sensor detects the ambient room temperature. This sensor reading is the main parameter used to regulate fan speed, under normal conditions.

Table 5-31 provides environmental specifications for the rx2660 servers:

**Table 5-31 rx2660 Environmental Specifications**

Parameter	Operating Range	Recommended Operating Range	Maximum Rate of Change	Non-Operating Range
Temperature	5-35 degrees C (up to 5000 feet)	20-25 degrees C (up to 5000 feet)	10 degrees C/hr with tape; 20 degrees C/hr without tape	-40 degrees to +70 degrees C
Relative Humidity	15-80% at 35 degrees C non-condensing	40-60% at 35 degrees C non-condensing	30% per hour non-condensing	

## Reporting Your Problems to HP

HP customer care will help you solve server problems and, if necessary, initiate appropriate service procedures.

Support is available on the web and by phone.

For information on contacting the HP IT Resource Center (ITRC) near you, go to: <http://www.itrc.hp.com>

## Online Support

To contact HP Customer Support online, see the Worldwide Limited Warranty and Technical Support Guide or visit us at <http://www.hp.com/go/bizsupport>. On our web page, enter the server model number (rx2660) and search the field.

The following information is available on this website:

- Software and firmware updates
- The latest drivers and utilities
- Additional documentation

## Phone Support

To contact HP customer support by phone, go to the HP IT Resource Center (ITRC) near you, at: <http://www.itrc.hp.com>. Local phone numbers are listed in your native language for help.

## Information to Collect Before you Contact Support



**NOTE:** It is highly recommended that you keep detailed records of any changes to your system, and of how system behavior has changed over time, or as a result of changes made to your system.

Before you contact HP support, you should:

1. Check the previous sections of this chapter and attempt to solve the problem.
  - Note failure symptoms and error indications (LEDs and messages).
  - Capture and permanently log the current SEL and FPL contents.
  - Try to determine precisely what did or did not happen.
2. Collect the following information:
  - The model number of your server (for example, rx2660).
  - The product number of your server. This can be found on the identification label, which is found at the front of the unit.
  - The serial number of your server. This can be found on the identification label.
3. Be familiar with your system configuration.
  - Are you using the LAN, RS-232, or web interface to monitor the server?
  - How many processors, DIMMs, and PCI cards have been installed?
  - What versions of processor, memory, and PCI cards are used and where are they installed?
  - What accessories are installed?
4. Determine the following
  - Which firmware versions are in use?
  - When did the problem start?
  - Have recent changes been made to the system?
  - Which OS and version is in use?

---

# 6 Removing and Replacing Server Components

This chapter describes safety information, required service tools, accessing the server, and the removal and replacement of hardware components for the HP Integrity rx2660 server.

This chapter addresses the following topics:

- “Service Tools Required” (page 140)
- “Safety Information” (page 140)
- “Server Component Classification” (page 141)
- “Accessing a Rack Mounted Server” (page 142)
- “Accessing a Pedestal Mounted Server” (page 143)
- “Removing and Replacing the Top Cover” (page 143)
- “Removing and Replacing the Airflow Guide” (page 145)
- “Removing and Replacing a Hot-Swappable Server Fan” (page 148)
- “Removing and Replacing a Hot-Swappable Power Supply” (page 152)
- “Removing and Replacing a Hard Drive Filler” (page 154)
- “Removing and Replacing a Hot-Pluggable SAS Hard Drive” (page 155)
- “Removing and Replacing the DVD Drive” (page 157)
- “Removing and Replacing the Front Bezel” (page 157)
- “Removing and Replacing the System Insight Display” (page 159)
- “Removing and Replacing the Fan Carrier Assembly” (page 161)
- “Removing and Replacing the I/O Fan Carrier Assembly” (page 164)
- “Removing and Replacing the I/O Backplane Assembly” (page 166)
- “Removing and Replacing a PCI-X/PCIe Card” (page 169)
- “Removing and Replacing the Fan / Display Board” (page 170)
- “Removing and Replacing System Memory” (page 173)
- “Removing and Replacing a Processor” (page 175)
- “Removing and Replacing the Power Supply Housing” (page 182)
- “Removing and Replacing the System and iLO 2 MP Battery” (page 185)
- “Removing and Replacing the Trusted Platform Module” (page 186)
- “Removing and Replacing the Smart Array P400 Controller and PCIe Expansion Board” (page 188)
- “Removing and Replacing the SAS Backplane Board” (page 193)
- “Removing and Replacing the System Board” (page 195)

## Service Tools Required

Service of this product requires one or more of the following tools:

- Electrically Conductive Field Service Grounding Kit (P/N 9300-1155)
- Processor install tool (attached to the processor cage airflow guide)
- 1/4 inch flat blade screwdriver
- ACX-15 Torx screwdriver (attached to the server rear panel)
- ACX-10 Torx screwdriver

## Safety Information

Use care to prevent injury and equipment damage when performing removal and replacement procedures. Voltages can still be present in the server even when powered down. Many assemblies are sensitive to damage from electrostatic discharge (ESD).

Follow the safety conventions listed below to ensure safe handling of components, prevent injury, and prevent damage to the server:

- When removing or installing servers components, follow the instructions provided in this guide.
- If installing a hot-swappable or hot-pluggable component when power is applied (fans are running), replace the server cover immediately to prevent overheating.
- If installing a hot-pluggable component, complete the required software intervention prior to removing the component.
- If installing an assembly that is neither hot-swappable, nor hot-pluggable, disconnect the power cable from the external server power receptacle.



---

**WARNING!** Ensure that the system is powered off and all power sources are disconnected from the server prior to removing or installing server hardware (unless you are removing or installing a hot-swappable or hot-pluggable component).

Voltages are present at various locations in the server whenever an ac power source is connected. This voltage is present even when the main power switch is turned off.

Failure to observe this warning may result in personal injury or damage to equipment.

---

- Do not wear loose clothing that may snag or catch on the server or on other hardware components.
- Do not wear clothing subject to the buildup of static electricity, such as wool or synthetic materials.
- If installing an internal assembly, wear an antistatic wrist strap and use a grounding mat, such as those included in the Electrically Conductive Field Service Grounding Kit (HP 9300-1155).
- Handle accessory boards and components by the edges only. Do not touch any metal-edge connectors or any electrical components on the accessory boards.

## Server Component Classification

The server components are classified into three major categories:

- Hot-swappable
- Hot-pluggable
- Cold-swappable

A brief explanation of each category and the classifications for the server components follow.

### Hot-Swappable Components

A component is defined as hot-swappable if you can remove it from the server while the server remains operational, and requires no software intervention prior to removing the component.



---

**NOTE:** Hot-swappable components are signified with red touch points.

---

The following are hot-swappable components:

- Fan unit
- Power supply (power supplies are only hot-swappable one at a time)
- Disk drive filler

### Hot-Pluggable Components

A component is defined as hot-pluggable if you can remove it from the server while the server remains operational, but software intervention is required prior to removing the component.



**NOTE:** Hot-pluggable components are signified with red touch points.

---

The only hot-pluggable components are the hard disk drives:

## Cold-Swappable Components

To remove and replace cold-swappable components (components that are neither hot-swappable nor hot-pluggable), shut down the operating system and power off the server. For complete instructions on shutting down the operating system and powering off the server, see [Chapter 4](#) (page 87).



**NOTE:** Cold-swappable components are signified with blue touch points.

---

The following are cold-swappable components:

- Front bezel
- DVD drive
- DIMMs
- Single- or dual-core processors
- System battery
- SAS core I/O card
- PCIe expansion card (optional)
- Smart Array P400 controller (optional)
- I/O backplane assembly
- Power backplane
- Diagnostic board
- Fan / display board
- SAS backplane
- System board

## Accessing a Rack Mounted Server

The server is designed for rack mounting. The following procedure explains how to gain access to the HP Integrity rx2660 that is mounted in an approved rack. For rack installation instructions, review the documentation in the universal rack-mounting kit included with your server.



**WARNING!** Ensure that all anti-tip features (front and rear anti-tip feet installed; adequate ballast properly placed; and so on) are employed prior to extending the server out of the rack.

---

## Extending the Server from the Rack



**NOTE:** Ensure that there is enough area (approximately 1.5 meters [4.5 ft.]) to fully extend the server from the front of the rack to work on it.

---

To extend the server from the rack, follow these steps:

1. Flip out the two pull handles located on both ends of the front bezel. This allows the server to slide out of the rack.

2. Slowly pull the server forward by the handles until it is fully extended.



---

**NOTE:** The server is fully extended when the rail clips are locked in place and the top cover is completely accessible.

---

**Figure 6-1 Extending the Server from the Rack**



## Inserting the Server into the Rack

To insert the server into the rack, follow these steps:

1. Press the rail clips on both sides of the server inward.
2. Push the server into the rack until it stops.

## Accessing a Pedestal Mounted Server

The server is also designed for use in a pedestal-mount configuration. The pedestal mount kit is a sheet metal enclosure that positions the server vertically. See the *HP Integrity rx2660 Server Pedestal Installation Guide* pedestal mounting kit documentation for the installation and access procedures.

## Removing and Replacing the Top Cover



---

**NOTE:** When the top cover is open or removed while the server is running, the server fans increase to high speed to assist cooling. When the top cover is replaced at the end of the operation, the server fans return to normal speed. The top cover must be replaced onto the server within three minutes, or the server shuts down automatically.

---

## Removing the Top Cover

To remove the top cover, follow these steps:

1. If rack mounted, fully extend the server out from the rack. See “Extending the Server from the Rack” (page 142).
2. Using the Allen wrench, provided on the rear panel of the server, unlock the cover release lever (if necessary) by turning the cam approximately 90 degrees counter-clockwise (1).
3. Pull up on the cover release lever to disengage the top cover from the server (2).
4. Slide the cover toward the rear of the server until the tabs release from the slots in the chassis (3).
5. Lift the cover off the server (4).

**Figure 6-2 Removing the Top Cover**

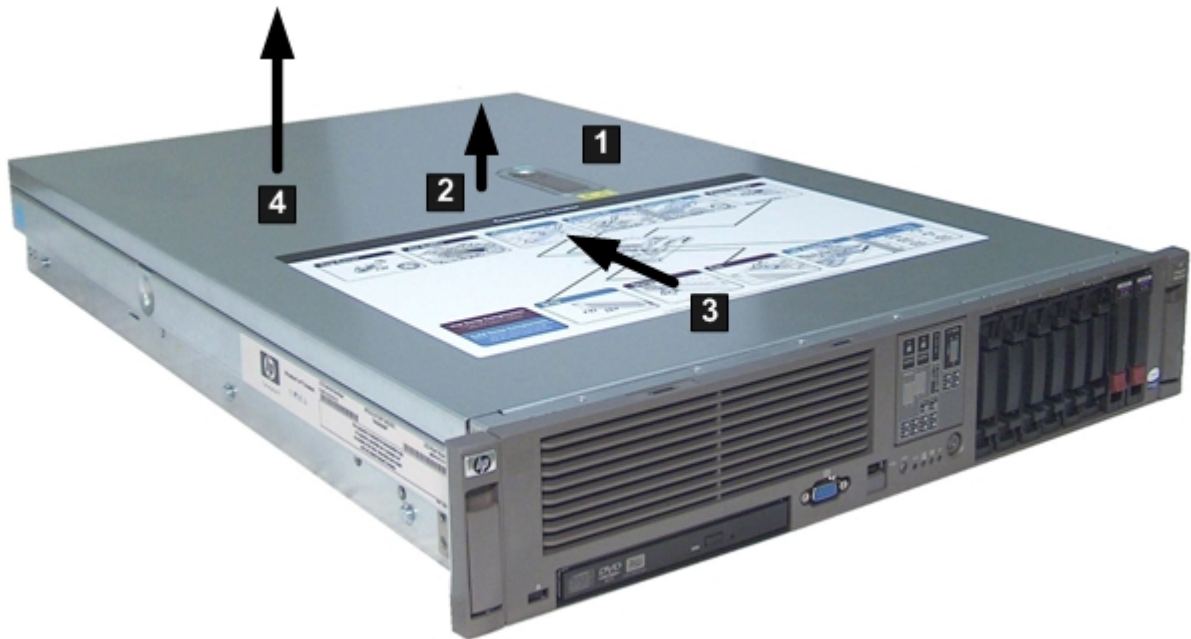

## Replacing the Top Cover

To replace the top cover, follow these steps:

1. Ensure the cover release lever is in the open position.
2. Align the tabs of the top cover with the corresponding slots in the server and insert the tabs into the slots (1).
3. Slide the cover forward until it is flush with the front of the server (2).
4. Push the cover release lever down into the latched position (3).
5. Lock the cover release lever (if required) by turning the cam approximately 90 degrees clockwise (4).
6. Replace the allen wrench on the rear panel of the server.



**Figure 6-3 Replacing the Top Cover**

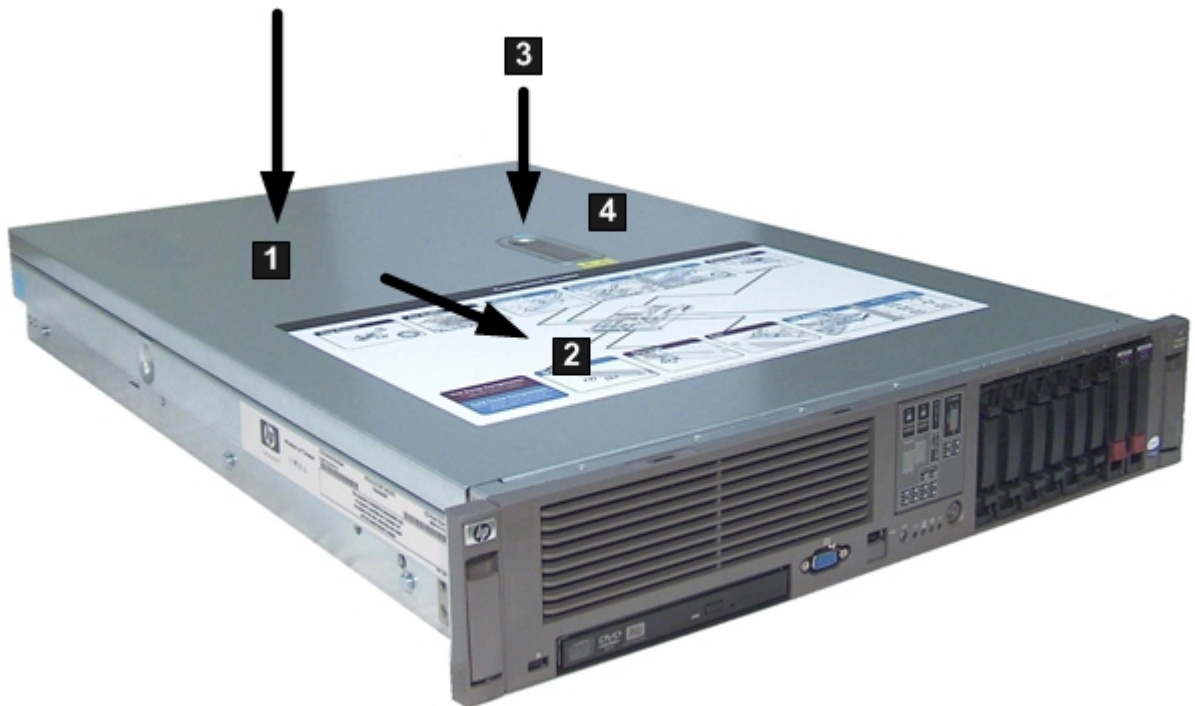

## Removing and Replacing the Airflow Guide

The airflow guide in the rx2660 server directs airflow from the system fans to the processors and the system memory on the system board. Use the following procedures to remove and replace the airflow guide.

### Removing the Airflow Guide

To remove the airflow guide from the server, follow these steps:

1. Remove the top cover. See “Removing the Top Cover” (page 143).  
Figure 6-4 shows the airflow guide location in the server

**Figure 6-4 Airflow Guide Location**

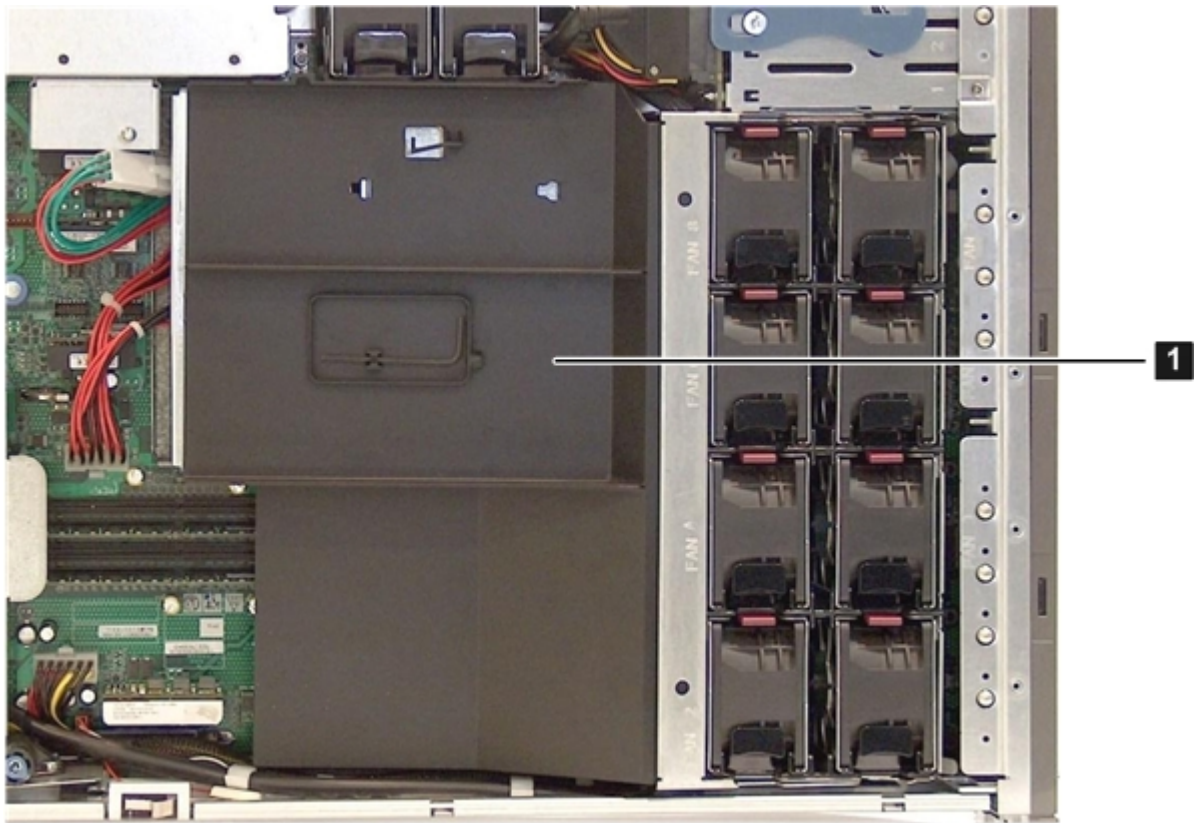

2. Lift the fan carrier handle up approximately 3 cm (1.5 in) (1). See Figure 6-5.

3. Lift the airflow guide straight up and out of the server (2)

**Figure 6-5 Fan Carrier Handle**



## Replacing the Airflow Guide

To replace the airflow guide, follow these steps:

1. Ensure the fan carrier handle is raised enough to replace the airflow guide.
2. Place the airflow guide on the edge of the fan carrier and push it down into place on the processor cage (1). See Figure 6-6 (page 148).
3. Push the fan carrier handle down until it is flush against the airflow guide (2).

**Figure 6-6 Replacing the Airflow Guide**

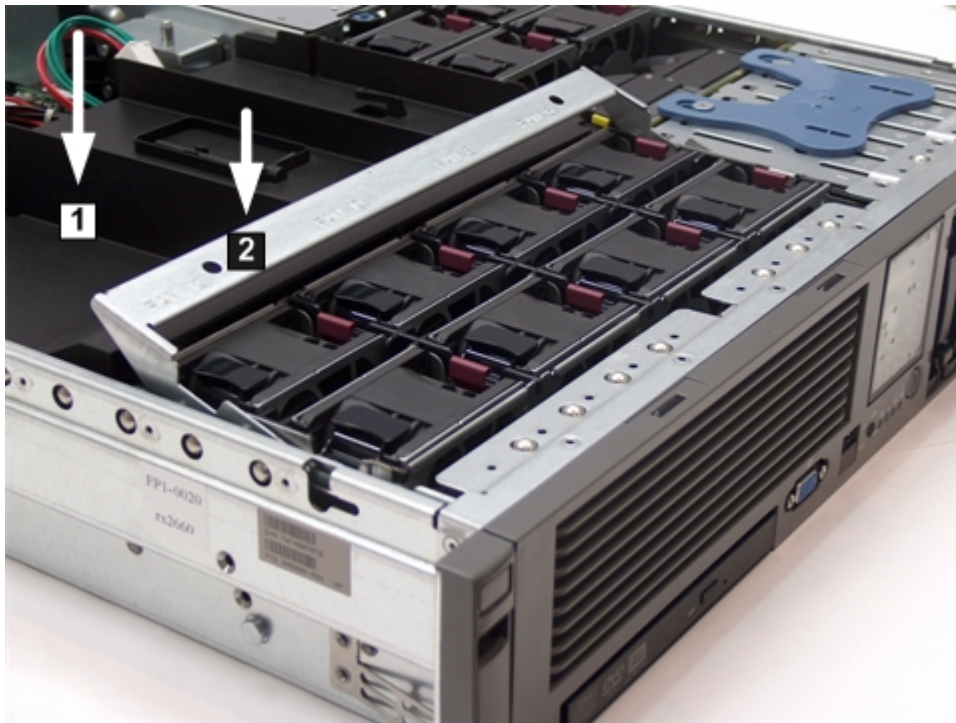

4. Ensure that the fans are seated correctly in their connectors by gently pressing down on each fan in the fan carrier.
5. Replace the top cover. See “Replacing the Top Cover” (page 144).
6. Replace the server back into the rack. See “Inserting the Server into the Rack” (page 143).

## Removing and Replacing a Hot-Swappable Server Fan

When removing a hot-swappable server fan from the server, there are different procedures depending on if you have a Data Center rx2660 server or an rx2660 Office Friendly server.

### Data Center rx2660 Server

Twelve fans cool the Data Center server. The fans are all redundant, hot-swappable, and interchangeable. Fans 1 through 8 are located in a removable fan carrier directly behind the front bezel. Fan units 9 through 12 are located in a removable I/O fan carrier between the SAS backplane and the I/O card cage. The server is set up into three cooling zones. Fans 1 through 4 cool Zone 1. Fans 5 through 8 cool Zone 2. Fans 9 through 12 cool Zone 3. Each zone can have one fan failure and still run, with the other fans in the zone speeding up until the failed fan is replaced. Replace the fans using the procedures in this section whether the server is powered on or off.

Figure 6-7 (page 149) shows the fan and cooling zone locations.

**Figure 6-7 Data Center Server Cooling Zones**

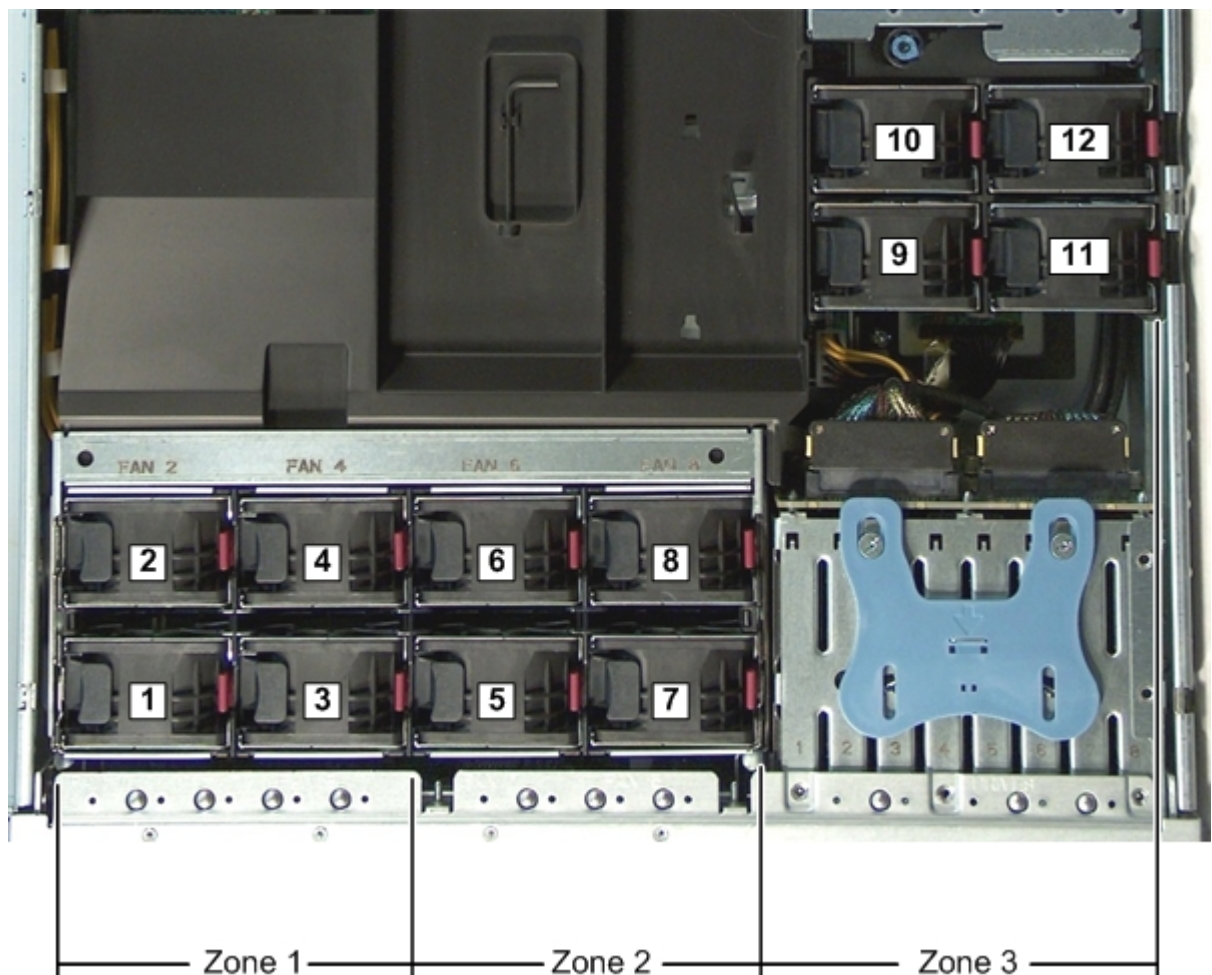

## Office Friendly Server

There are six interchangeable, hot-swappable dual-rotor server fans in the Office Friendly rx2660 server. The Office Friendly fans have two fan rotors per fan. Fans 1 through 4 are located in a removable fan carrier directly behind the front bezel. Fan units 5 and 6 are located in a removable I/O fan carrier between the SAS backplane and the I/O card cage. The server is set up into three cooling zones. Fans 1 and 2 cool Zone 1. Fan 3 and 4 cool Zone 2. Fans 5 and 6 cool Zone 3. Fan redundancy is only supported in Zone 1 and Zone 3. If you lose one fan rotor in either of these zones, the rest of the fans in that zone run at maximum speed and the server does not shut down. If you lose one fan rotor in Zone 2, the BMC performs a soft shutdown in 40 seconds.

Figure 6-8 (page 150) shows the fan and cooling zone locations.

**Figure 6-8 Office Friendly Server Cooling Zones**

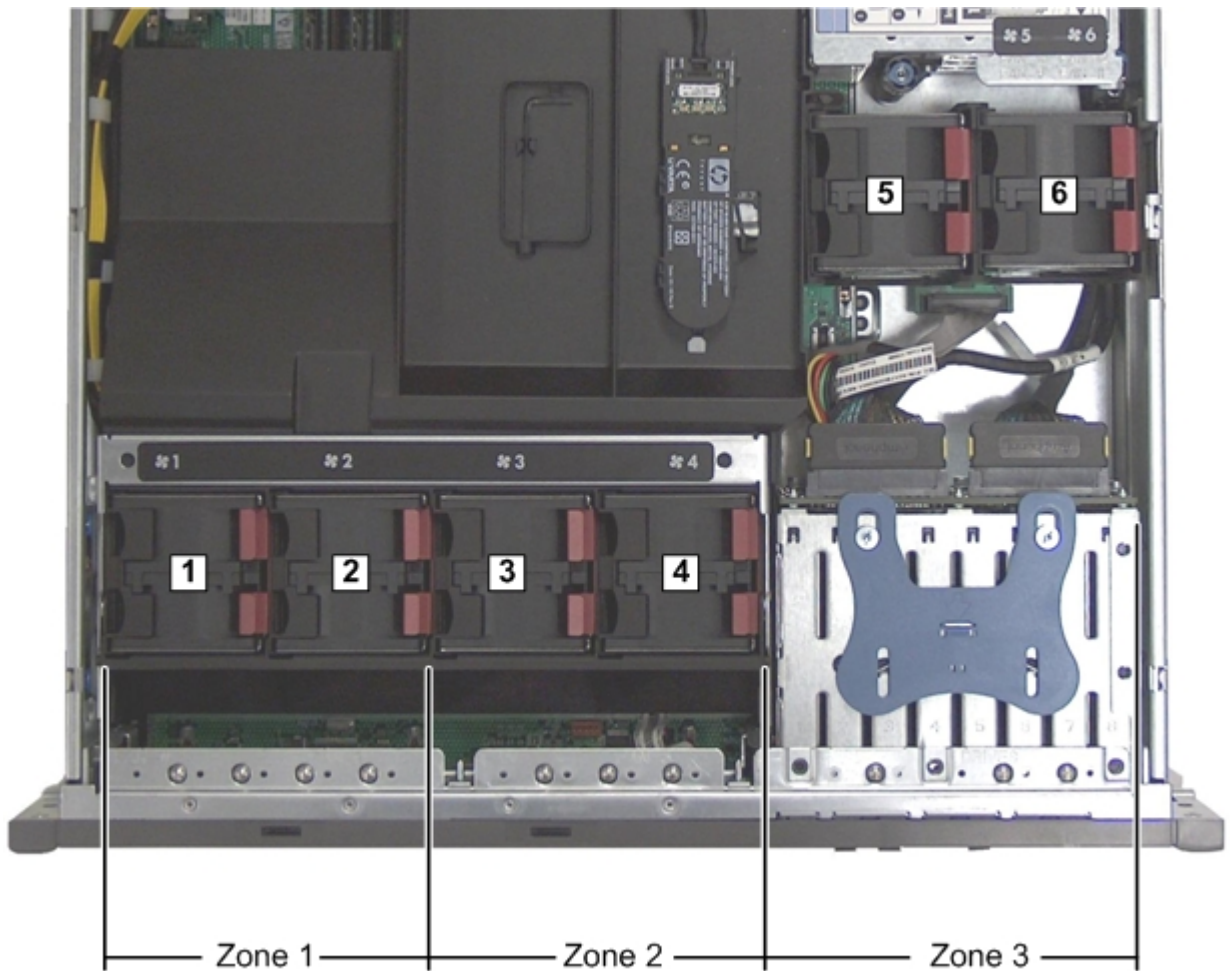

## Removing a Server Fan



**CAUTION:** Observe all ESD safety precautions before attempting this procedure. Failure to follow ESD safety precautions might result in damage to the server.



**NOTE:** A hot-swappable device does not require interaction with the operating system before the device is removed from or installed into the server.

To remove a server fan unit, follow these steps:

1. If rack mounted, slide the server completely out from the rack. See “Extending the Server from the Rack” (page 142).
2. Remove the top cover. See “Removing the Top Cover” (page 143).



---

**IMPORTANT:** For the Data Center rx2660 server, you can have one failed fan per zone. The fans speed up to compensate for the failed fan. If two fans fail in a given zone, you have three minutes to remove the top cover, replace the failed fan and put the top cover back onto the server. Otherwise, the server performs a soft shut down due to an overheat condition.

For the Office Friendly server, you can have one failed fan rotor per zone in Zone 1 or Zone 3. The fans speed up to compensate for the failed fan rotor. If you have two rotors fail in Zone 1 or Zone 3, or one rotor fail in Zone 2, you have 40 seconds to replace the failed fan. Otherwise, the server performs a soft shut down due to an overheat condition.

---

3. When removing fans from a Data Center server, insert thumb and forefinger into the openings on the top of the fan and squeeze until the fan releases from the socket (1). See Figure 6-9. When removing fans from an Office Friendly server, use two hands to squeeze the two latches on the server fan (1). See Figure 6-10.
  4. Pull the fan straight up and out of the server (2).
- 



**CAUTION:** Be careful when removing fans. If you remove them while the server is receiving power, keep your fingers away from the fan air intakes. The openings are large enough for your fingers to contact moving fan blades. The fans are labeled as follows:



---

Figure 6-9 shows the Data Center server fan.

#### Figure 6-9 Removing and Replacing a Data Center Server Fan

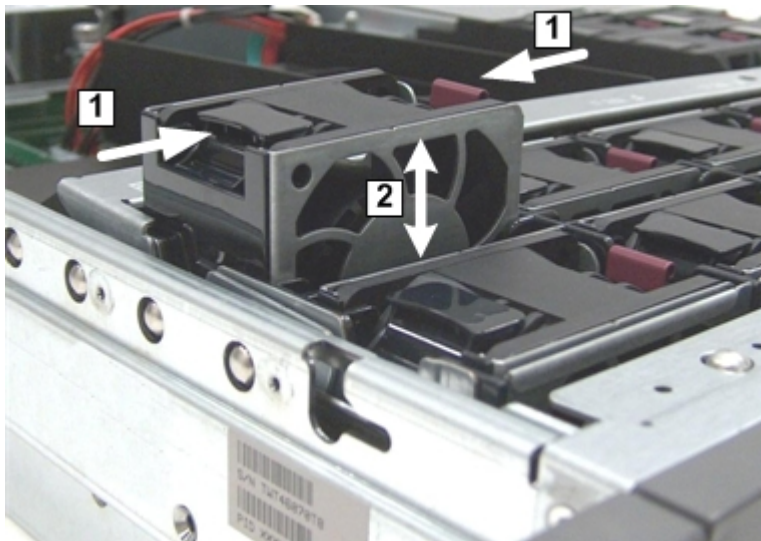
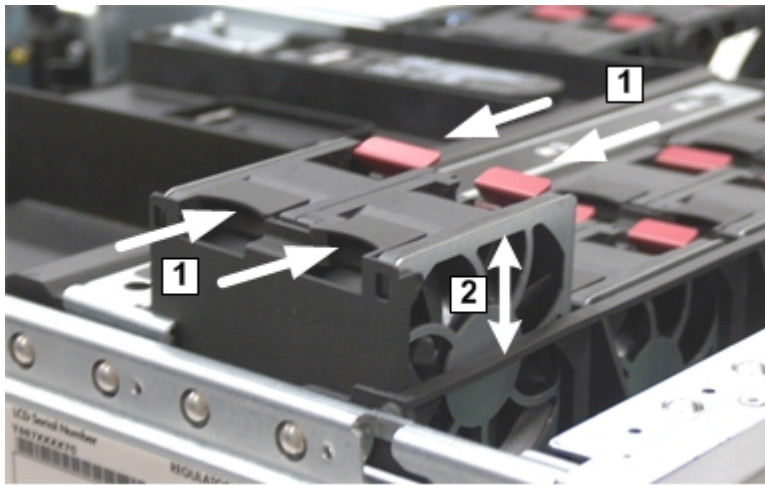

Figure 6-10 shows an Office Friendly server fan.

**Figure 6-10 Removing and Replacing an Office Friendly Server Fan**



## Replacing a Server Fan

To replace a server fan, follow these steps:



**CAUTION:** To prevent server components from overheating, replace the fan within 40 seconds. Failure to observe this caution causes the server to automatically shut down to prevent an overtemperature condition.



**NOTE:** The fan unit is keyed to fit into the fan housing in one orientation only. The release tab is on the right side of the fan unit when viewed from the front of the server.

1. Push the fan unit firmly into the fan housing until it is flush with the top of the server (2). See Figure 6-9 or Figure 6-10 depending on the type of fan in your server.



**NOTE:** It can take up to 10 seconds after installing a fan for the new fan LED to turn off.

2. Check the diagnostic LED on the front panel that corresponds to the replaced fan unit.
  - If the fan is functioning normally, the LED turns off.
  - If the fan fails, the LED is lit amber.
3. Replace the top cover. See “Replacing the Top Cover” (page 144).

## Removing and Replacing a Hot-Swappable Power Supply

Depending on the server you have, the different servers have different power requirements. The Data Center rx2660 server has one or two hot-swappable power supplies installed. The Office Friendly rx2660 server has two power supplies installed. These power supplies are located at the rear of the server in a removable power supply housing.

The supported configuration of the Data Center server requires a minimum of one power supply. You can install or replace a hot-swappable power supply using the procedures in this section when power is on or off (if you have two power supplies).



The supported configuration of the Office Friendly server is two power supplies. You can install or replace a hot-swappable power supply using the procedures in this section when power is on or off.



**CAUTION:** Observe all ESD safety precautions before attempting this procedure. Failure to follow ESD safety precautions can cause damage to the server.

---



**NOTE:** A hot-swappable device does not require that you interact with the operating system before the device is removed from, or installed into, the server.

Power to the server does not have to be off to install or replace a hot-swappable power supply as long as there is another power supply installed in the server, and is connected to a power source.

---

## Power Supply Loading Guidelines

The supported configuration for the Data Center server requires that at least one power supply be installed in slot P1 or slot P2. You can install a second, optional, hot-swappable power supply to provide 1+1 capability. The right side (viewed from the rear of the server) hot-swappable power supply is identified as P1, and the second hot-swappable power supply to the left is P2. See Figure 6-11.

The supported configuration for the Office Friendly server requires that both power supplies be installed.

---



**CAUTION:** When a second power supply is not used (Data Center server only), the empty power supply slot must remain covered with the supplied metal filler panel. Failure to observe this caution can result in damage due to overheating.

Install the hot-swappable power supply in the server before attaching the new power cord. Failure to observe this precaution can result in damage to the server.

---



**NOTE:** The Office Friendly server can run on only one power supply. However, two power supplies must be installed to meet the acoustic requirements for an Office Friendly server. Replace a failed power supply as soon as possible.

---

## Removing a Power Supply

To remove a power supply, follow these steps:

1. Move the cable management arm from the rackslide nearest the power supplies enough to allow access to the power supplies.
2. Remove the power cord plug from the power supply receptacle.
3. Grasp the power supply handle and push the locking tab down with your thumb to release the power supply from the socket on the power supply riser board (1).
4. Supporting the power supply with both hands, pull the power supply out of the server (2).

**Figure 6-11 Removing and Replacing a Power Supply**

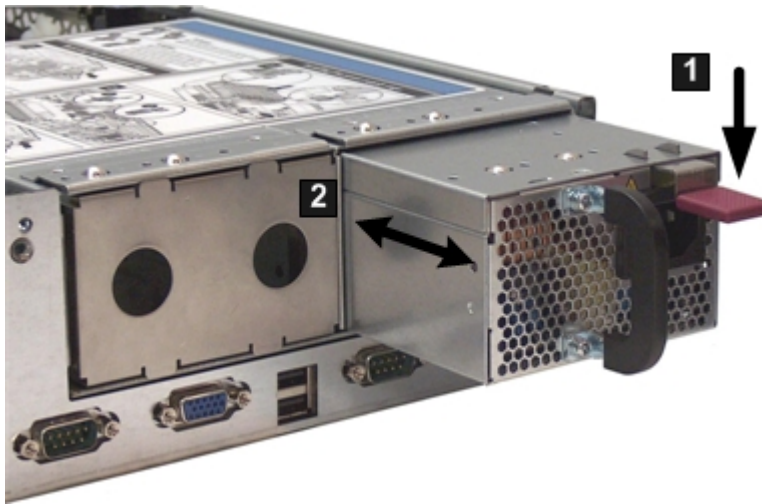

## Replacing a Power Supply

To replace a power supply, follow these steps:

1. Remove the metal filler panel, if necessary.
2. Supporting the power supply with both hands, slide it into the empty slot until it clicks into place (2).



---

**IMPORTANT:** Ensure the power supply is flush with the adjacent power supply or metal filler panel.

---

3. Plug the power cord into the power supply receptacle.
4. Attach the power cord to the power cord anchor attached to the power supply.

## Removing and Replacing a Hard Drive Filler

There are hard drive fillers installed in a vertical orientation for all slots that do not contain a hard drive. The slot fillers are hot-swappable.



---

**IMPORTANT:** For cooling purposes, always leave hard drive fillers in slots that do not contain a hard drive.

---

## Removing a Hard Drive Filler

To remove a hard drive filler, follow these steps:

1. Squeeze the tabs on the front of the filler to release it from the slot in the drive bay (1).
2. Pull gently until the filler slides out of the server (2).

**Figure 6-12 Removing and Replacing a Hard Drive Filler**

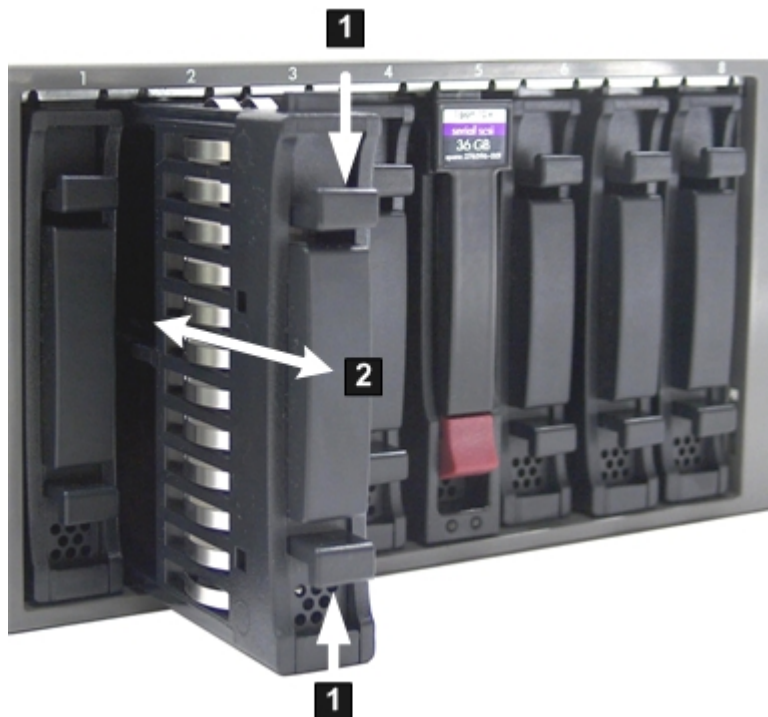

## Replacing a Hard Drive Filler

To replace a hard drive filler, follow these steps:

1. Orient the hard drive filler so that the airflow holes are on the bottom of the filler.
2. Insert the filler into the slot guides, and slide the filler into the slot until it clicks into place and is fully seated (2).

## Removing and Replacing a Hot-Pluggable SAS Hard Drive

You can install up to eight hot-pluggable SAS hard drives, located on the front panel of the server. Replace the SAS hard drives using these procedures when server power is on or off.

The SAS hard drives are small form factor 2.5 in. disk drives. Supported capacities are as follows:

- 36 GB
- 73 GB
- 146 GB



**CAUTION:** A hot-pluggable device might require that you interact with the operating system before you can safely remove it from, or install it into, the server. Verify that the operating system supports removing and replacing disk drives while the operating system is running. If the operating system does not support this feature, shut down the operating system before attempting this procedure. Failure to observe this caution can cause system failure.



**NOTE:** The replacement SAS hard drive must have the same product number as the disk drive that is replaced.

## Removing a SAS Hard Drive

To remove a SAS hard drive, follow these steps:

1. Push down on the release tab (1). The drive extraction handle extends from the drive.
2. Pull the extraction handle up (2).

3. Gently slide the hot-pluggable hard drive out of the server (3).

**Figure 6-13 Removing a Hot-Pluggable Hard Drive**

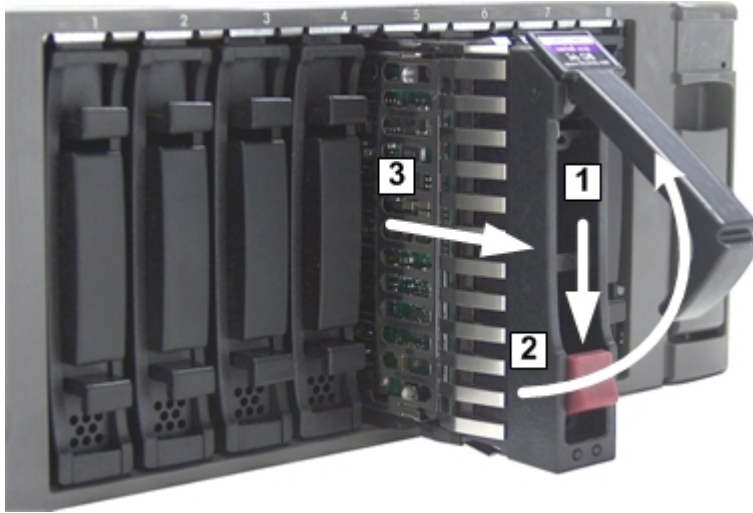

**NOTE:** For cooling purposes, always leave hard drive fillers in empty drive slots.

## Replacing a SAS Hard Drive

To install a SAS hard drive, follow these steps:



**NOTE:** Load the SAS hard drives in order, starting with number 8, working from right to left.

1. Remove the SAS hard drive filler if required. See “Removing a Hard Drive Filler” (page 154).



**NOTE:** Save the SAS hard drive filler for future use. For cooling purposes, always place hard drive fillers in empty drive slots.

2. Insert the SAS hard drive into the slot guides, and slide the drive into the slot until it seats into the socket on the disk backplane (1). See Figure 6-14 (page 156) for installation procedures.
3. Close the drive-ejector handle by pushing it down until it clicks into place (2).

**Figure 6-14 Replacing a SAS Hard Drive**

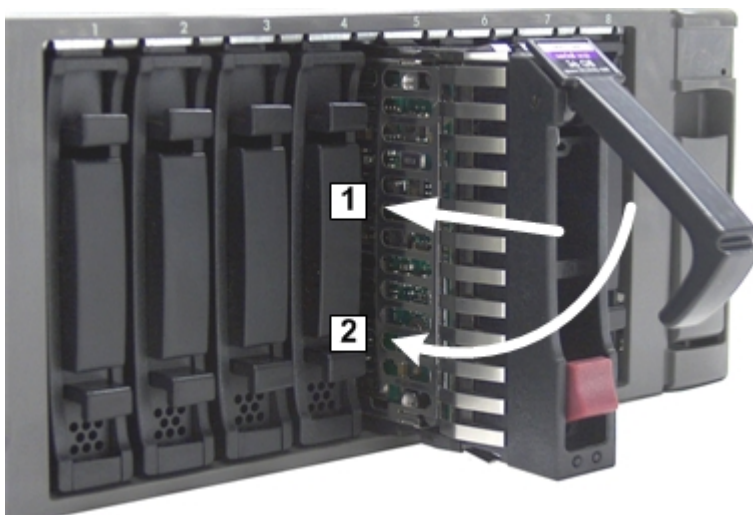

4. Observe the following SAS hard drive LEDs to ensure the drive is functional.
  - Drive activity LED
  - Drive status LED

## Removing and Replacing the DVD Drive

The DVD drive is located in the front of the server.



**WARNING!** Ensure that the system is powered off and all power sources are disconnected from the server prior to performing this procedure.

Voltages are present at various locations in the server whenever an ac power source is connected. This voltage is present even when the main power switch is in the off position.

Failure to observe this warning can result in personal injury or damage to equipment.

---



**CAUTION:** Observe all ESD safety precautions before attempting this procedure. Failure to follow ESD safety precautions can result in damage to the server.

---

### Removing the DVD Drive

To remove the DVD drive, follow these steps:

1. Power off the server and disconnect the power cables. See “Powering On and Powering Off the Server” (page 78).
2. Insert a tool (such as a flat head screwdriver) that fits into the release slot to the left of the DVD drive, and then push firmly to eject the drive out of the bay (1).
3. Pull the DVD drive straight out to remove it from the server (2).

**Figure 6-15 Removing the DVD Drive**

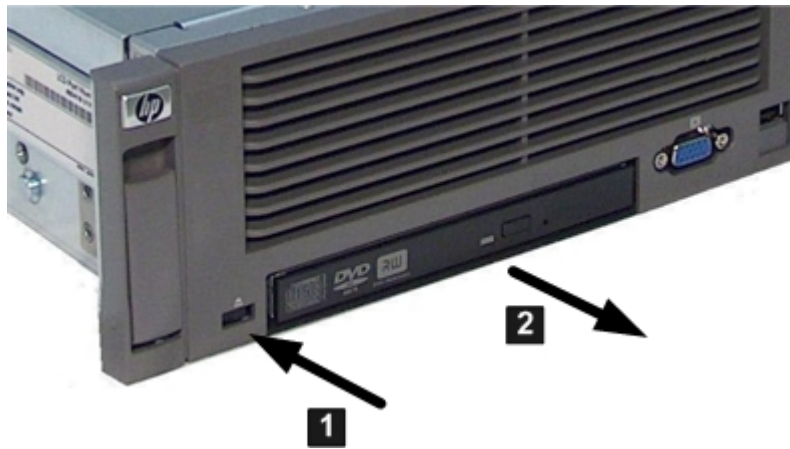

### Replacing the DVD Drive

To replace a DVD drive, follow these steps:

1. Insert the DVD drive into the slot on the server, and then push it straight into the drive bay until it clicks into place.
2. Reconnect the power cables and power on the server. See “Powering On and Powering Off the Server” (page 78).

## Removing and Replacing the Front Bezel

The front bezel provides server control and port access, and LED interfaces. You must power off the server to remove the front bezel.

## Removing the Front Bezel

To remove the front bezel, follow these steps:

1. Power off the server and disconnect the power cables. See “Powering On and Powering Off the Server” (page 78).
2. If rack mounted, slide the server out from the rack. See “Extending the Server from the Rack” (page 142).
3. Remove the four T-10 screws that hold the bezel to the server. There are two screws on each side of the server that attach to the bezel through the rack flanges (3).

Figure 6-16 shows the front bezel.

**Figure 6-16 Removing the Front Bezel**



4. Remove the top cover. See “Removing the Top Cover” (page 143).
5. Remove the system fans in the fan carrier. See “Removing a Server Fan” (page 150).
6. Remove the fan carrier. See “Removing the Fan Carrier Assembly” (page 161).
7. Disconnect the System Insight Display power cable from the fan/display board. See Figure 6-17.
8. Remove the T-10 bezel screw next to the System Insight Display on the inside of the server. See Figure 6-17.

**Figure 6-17 Bezel Screw Location**

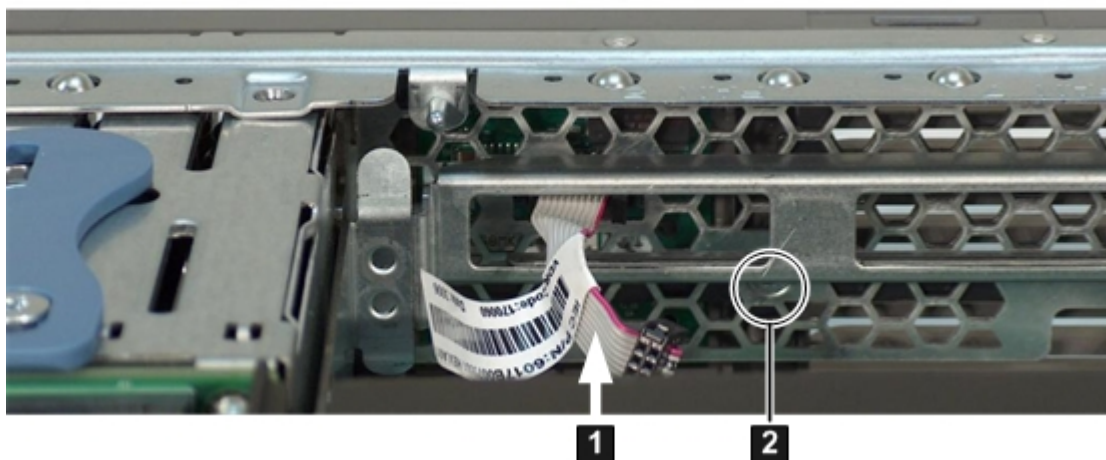

9. Grasp the bottom of the bezel and pull gently until it is free from the server. Rotate the bezel slightly upward and lift it off the server chassis.
10. While removing the bezel, make sure to guide the power connector on the System Insight Display through the hole in the server chassis.

- 1 System Insight Display power cable (disconnected from fan/display board)
- 2 T-10 bezel screw location

## Replacing the Front Bezel

To replace the front bezel, follow these steps:

1. Guide the power connector on the System Insight Display through the hole in the server chassis. See Figure 6-17.
2. Align the bezel slots with the tabs on the server, and rotate the bezel downward and gently push it into place so it is flush with the front server wall.
3. Replace the screws that attaches the bezel to the server.
4. Connect the System Insight Display power cable to the fan/display board.
5. Replace the fan carrier into the server. See “Replacing the Fan Carrier Assembly” (page 163).
6. Replace the system fans. See “Replacing a Server Fan ” (page 152).
7. Replace the top cover. See “Replacing the Top Cover” (page 144).
8. If rack mounted, slide the server completely into the rack. See “Inserting the Server into the Rack” (page 143).
9. Reconnect the power cables and power on the server. See “Powering On and Powering Off the Server” (page 78).

## Removing and Replacing the System Insight Display

The System Insight Display is located in the front of the server and is attached to the front bezel.



**WARNING!** Ensure that the system is powered off and all power sources are disconnected from the server prior to performing this procedure.

Voltages are present at various locations in the server whenever an ac power source is connected. This voltage is present even when the main power switch is off.

Failure to observe this warning can result in personal injury or equipment damage.

---



**CAUTION:** Observe all ESD safety precautions before attempting this procedure. Failure to follow ESD safety precautions can result in damage to the server.

---

## Removing the System Insight Display

To remove the System Insight Display, follow these steps:

1. Power off the server and disconnect the power cables. See “Powering On and Powering Off the Server” (page 78).
2. If rack mounted, slide the server completely out from the rack. See “Extending the Server from the Rack” (page 142).
3. Remove the top cover. See “Removing the Top Cover” (page 143).
4. Remove the front fan carrier assembly. See “Removing the Fan Carrier Assembly” (page 161).
5. Disconnect the System Insight Display power cable from the fan/display board.
6. Remove the front bezel from the server. See “Removing the Front Bezel” (page 158)
7. Push on the two plastic clips that hold the System Insight Display to the bezel (1) and push the System Insight Display through the front of the bezel.

Figure 6-18 (page 160) shows the System Insight Display.

**Figure 6-18 Removing the System Insight Display from the Front Bezel**

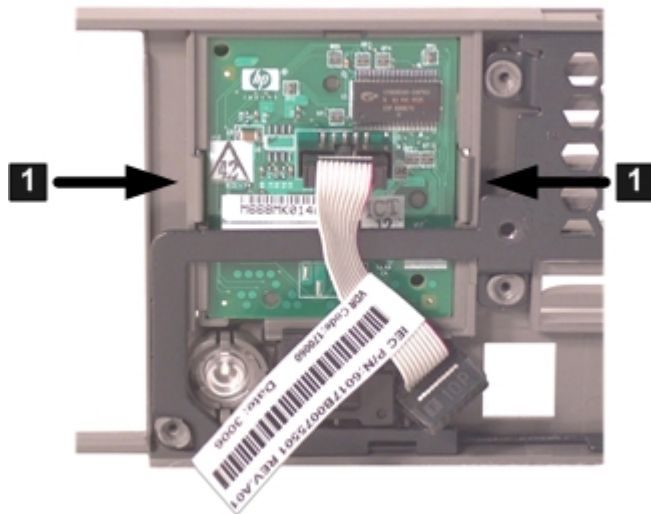

## Replacing the System Insight Display

To replace the System Insight Display, follow these steps:

1. Insert the System Insight Display into the opening in the front bezel and push the board toward the rear of the server until it snaps into place.



---

**NOTE:** The System Insight Display is keyed to fit into the bezel in only one direction.

---

3. Replace the front bezel on the front of the server. See “Replacing the Front Bezel” (page 159).
4. Reconnect the System Insight Display power cable to the fan/display board.
5. Replace the front fan carrier assembly. See “Replacing the Fan Carrier Assembly” (page 163).
6. Replace the fans into the fan carrier. See “Replacing a Server Fan ” (page 152).
7. Replace the top cover. See “Replacing the Top Cover” (page 144).
8. Reconnect the power cables and power on the server. See “Powering On and Powering Off the Server” (page 78).
9. Respond **YES** to prompts regarding copying information onto the new board.



10. Verify the serial number and model string data information copied onto the new board by doing the following:
  - a. Boot to EFI.
  - b. Enter **Service** mode:

```
Shell> sysmode service
Current System Mode: ADMIN
You are now in SERVICE mode.
```
  - c. Use the `sysset` command to verify that all values are set:

```
Shell> sysset

System Information:
Manufacturer: hp
Product Name: server rx2660
Product Number: AB463A
Secondary Product Number is Identical
Serial number: SGH43442VB
Secondary Serial Number is Identical
UUID: 3C33C58E-2E5A-11D8-A33B-4188C0AEFAE2 (Valid)
Secondary UUID is Identical
Product ID: 0x601
```



---

**NOTE:** Due to the type of server you purchased, your `sysset` output may not exactly match the output shown here.

---

11. Verify the System Insight Display replacement and operation by using the following system utilities:
  - Use the `iLO 2 MP DF` command to check the customer replaceable unit (CRU) ID of the System Insight Display.

## Removing and Replacing the Fan Carrier Assembly

The server contains an fan carrier assembly, located behind the front bezel, that houses eight of the 12 server fans if you have a Data Center rx2660 server; or four of the six fans if you have an Office Friendly Server.



---

**WARNING!** Ensure that the system is powered off and all power sources are disconnected from the server prior to performing this procedure.

Voltages are present at various locations in the server whenever an ac power source is connected. This voltage is present even when the main power switch is off.

Failure to observe this warning can result in personal injury or equipment damage.

---



---

**CAUTION:** Observe all ESD safety precautions before attempting this procedure. Failure to follow ESD safety precautions can result in damage to the server.

---

## Removing the Fan Carrier Assembly

This procedure applies to the Data Center rx2660 server fan assembly, or the Office Friendly server fan assembly.

To remove the fan carrier assembly, follow these steps:

1. Power off the server, and disconnect the power cables. See “Powering On and Powering Off the Server” (page 78).
2. If rack mounted, slide the server completely out from the rack. See “Extending the Server from the Rack” (page 142).
3. Remove the top cover. See “Removing the Top Cover” (page 143).

4. Remove all of the fans from the fan carrier. See “Removing a Server Fan” (page 150).
5. Lift up on the fan carrier assembly handle and rotate it approximately 90 degrees (1). See Figure 6-19.

**Figure 6-19 Removing and Replacing the Fan Carrier Assembly**

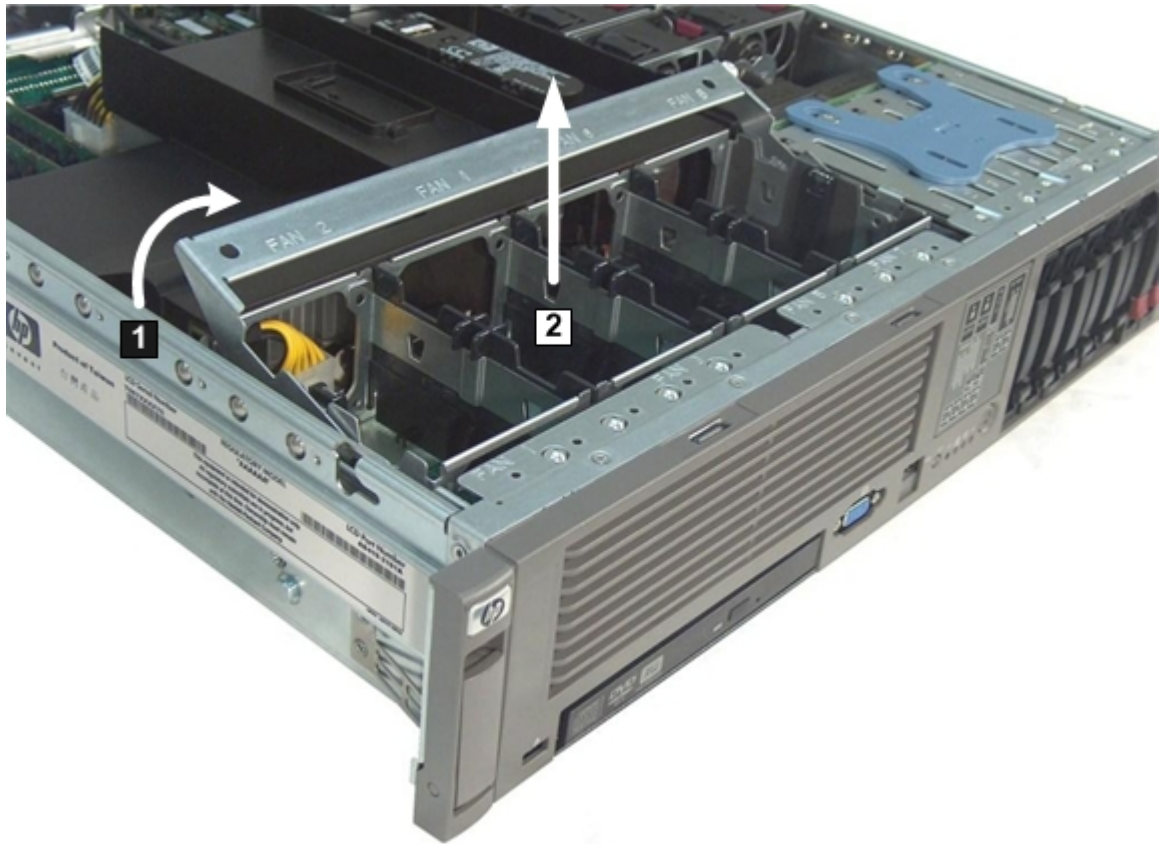

- Lift the fan carrier assembly straight up and out of the server (2). See Figure 6-20 or Figure 6-21.

**Figure 6-20 Data Center Fan Carrier Assembly Removed**

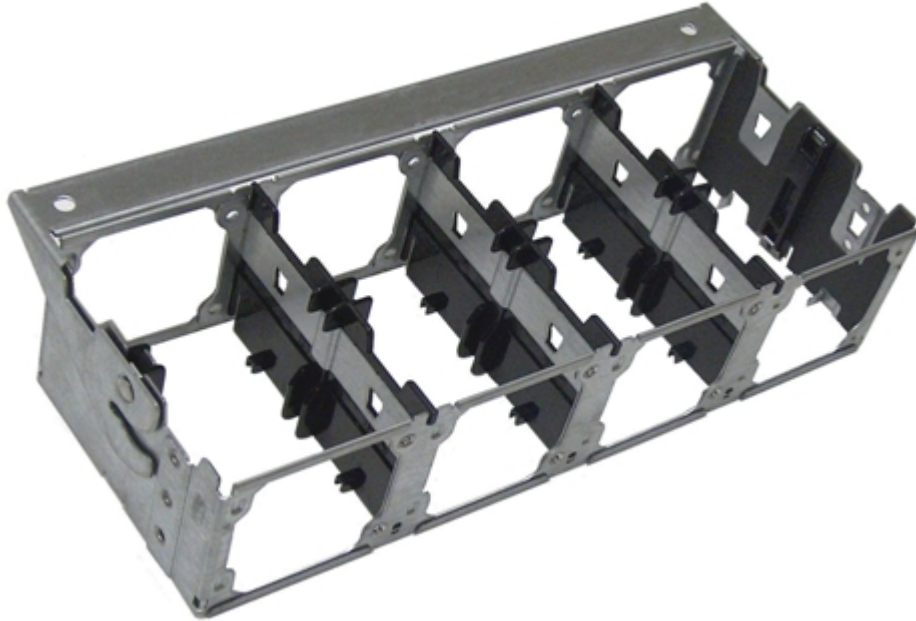

**Figure 6-21 Office Friendly Server Fan Carrier Assembly Removed**

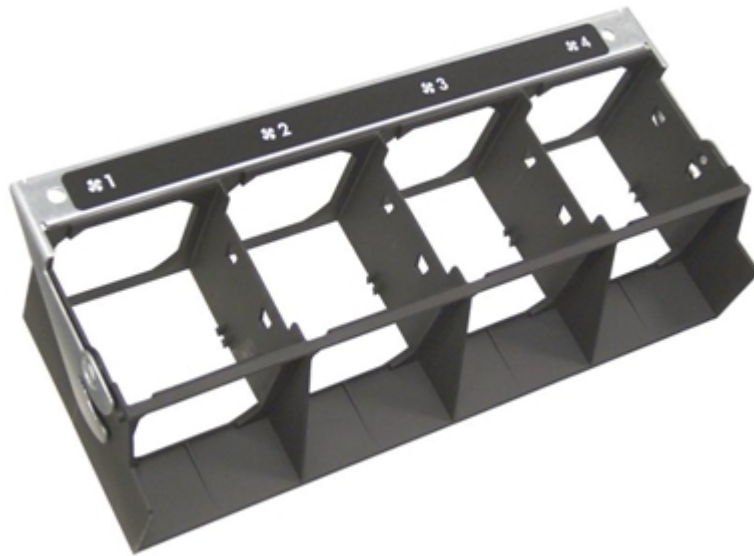

## Replacing the Fan Carrier Assembly

This procedure applies to the Data Center rx2660 server fan assembly, or the Office Friendly server fan assembly.

To replace the fan carrier assembly, follow these steps:

1. Align the tabs on the fan carrier assembly with the guide slots on the server and slide the assembly into the server. See [Figure 6-19](#).
2. Rotate the fan carrier assembly handle downward approximately 90 degrees until it closes flush against the airflow guide.
3. Install the fans in to the fan carrier. See [“Replacing a Server Fan ” \(page 152\)](#).
4. Replace the top cover. See [“Replacing the Top Cover” \(page 144\)](#).
5. If rack mounted, slide the server completely into the rack. See [“Inserting the Server into the Rack” \(page 143\)](#).
6. Reconnect the power cables and power on the server. See [“Powering On and Powering Off the Server” \(page 78\)](#).

## Removing and Replacing the I/O Fan Carrier Assembly

The server contains an I/O fan carrier assembly, located behind the SAS backplane, that houses four of the 12 server fans in the Data Center server, or two of the six fans if you have an Office Friendly Server.



**WARNING!** Ensure that the system is powered off and all power sources are disconnected from the server prior to performing this procedure.

Voltages are present at various locations in the server whenever an ac power source is connected. This voltage is present even when the main power switch is in the off position.

Failure to observe this warning can result in personal injury or damage to equipment.

---



**CAUTION:** Observe all ESD safety precautions before attempting this procedure. Failure to follow ESD safety precautions can result in damage to the server.

---

## Removing the I/O Fan Carrier Assembly

This procedure applies to both the Data Center server and Office Friendly server.

To remove the I/O fan carrier assembly, follow these steps:

1. Power off the server and disconnect the power cables. See [“Powering On and Powering Off the Server” \(page 78\)](#).
2. If rack mounted, slide the server completely out from the rack. See [“Extending the Server from the Rack” \(page 142\)](#).
3. Remove the top cover. See [“Removing the Top Cover” \(page 143\)](#).
4. Disconnect the I/O fan carrier assembly power cable (1). See [Figure 6-22 for the Data Center server, or Figure 6-23 \(page 165\) for the Office Friendly server](#).
5. Remove the fans from the I/O fan assembly. See [“Removing a Server Fan” \(page 150\)](#).
6. Loosen the four T-15 screws that hold the I/O fan assembly to the system board. See [Figure 6-22 \(page 165\) for the Data Center server, or Figure 6-23 for the Office Friendly server](#).

**Figure 6-22 Removing and Replacing the Data Center Server I/O Fan Carrier Assembly**

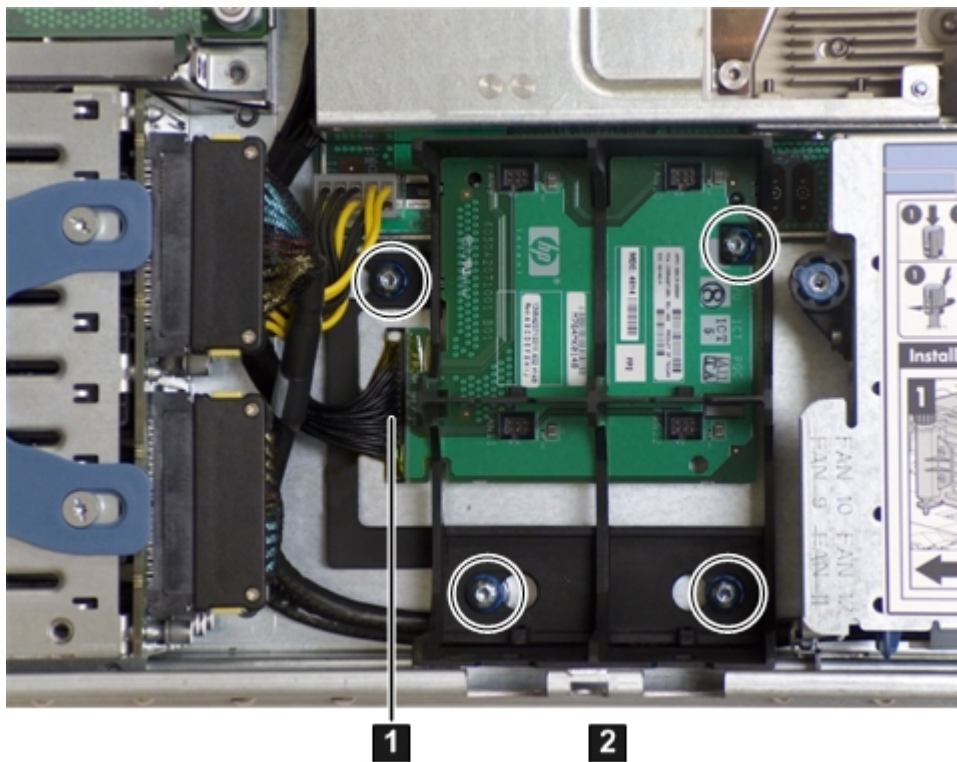

- 1** Power cable
- 2** T-15 screws (4)

**Figure 6-23 Removing and Replacing the Office Friendly Server I/O Fan Carrier Assembly**

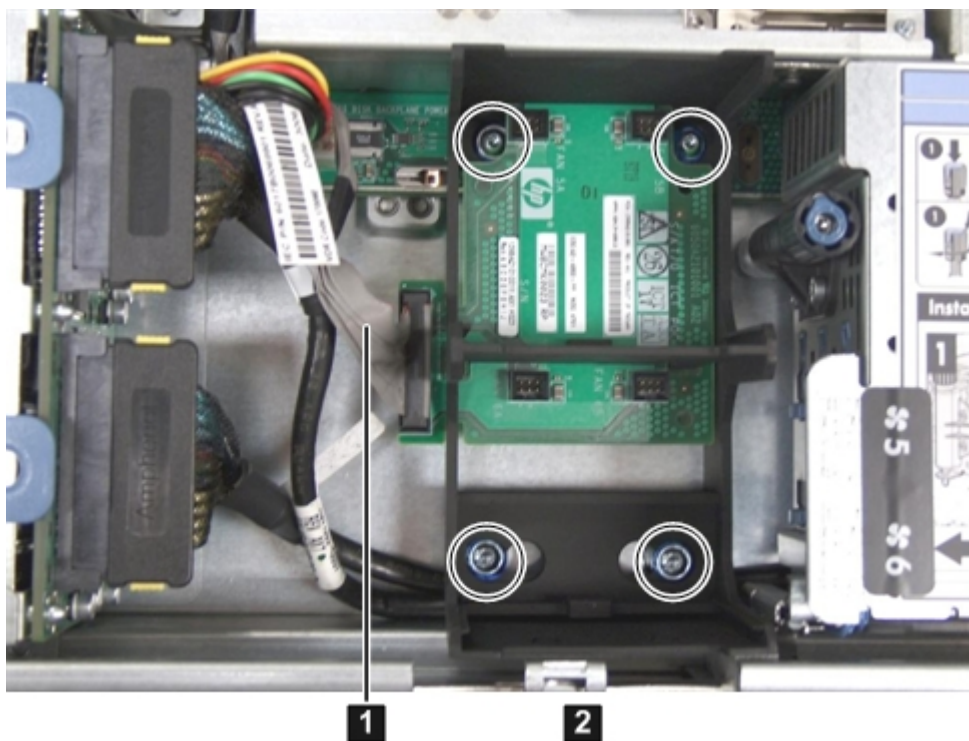

- 1** Power cable
- 2** T-15 screws (4)

7. Lift the assembly straight up and out of the server.

## Replacing the I/O Fan Carrier Assembly

This procedure applies to both the Data Center server and Office Friendly server.

To replace the I/O fan carrier assembly, follow these steps:

1. Align the pins on the system board with the holes in the I/O fan assembly, and put the assembly straight down into the server.
2. Attach the assembly to the server chassis by tightening the four T-15 screws. See Figure 6-22 (page 165) or Figure 6-23 depending on your server type.
3. Install the fans into the I/O fan carrier assembly. See “Replacing a Server Fan ” (page 152).
4. Reconnect the I/O fan carrier assembly power cable. See Figure 6-22 (page 165) or Figure 6-23 (page 165).
5. Replace the top cover. See “Replacing the Top Cover” (page 144).
6. If rack mounted, slide the server completely into the rack. See “Inserting the Server into the Rack” (page 143).
7. Reconnect the power cables and power on the server. See “Powering On and Powering Off the Server” (page 78).

## Removing and Replacing the I/O Backplane Assembly

The I/O backplane assembly consists of the I/O backplane and a sheet metal enclosure. The I/O backplane contains three full-length public I/O slots.

### Removing the I/O Backplane Assembly

Observe the following warning and cautions before removing the I/O backplane assembly.



**WARNING!** Ensure that the system is powered off and all power sources are disconnected from the server prior to performing this procedure.

Voltages are present at various locations in the server whenever an ac power source is connected. This voltage is present even when the main power switch is in the off position.

Failure to observe this warning can result in personal injury or damage to equipment.



**CAUTION:** Observe all ESD safety precautions before attempting this procedure. Failure to follow ESD safety precautions can result in damage to the server.

**CAUTION:** Record the slot location of all PCI cards as they are removed. Depending on the operating system, replacing PCI cards in a different location might require system reconfiguration and might cause boot failure.

To remove the I/O backplane assembly, follow these steps:

1. Power off the server and disconnect the power cables. See “Powering On and Powering Off the Server” (page 78).
2. If rack mounted, slide the server completely out from the rack. See “Extending the Server from the Rack” (page 142).
3. Remove the top cover. See “Removing the Top Cover” (page 143).
4. Disconnect all internal and external cables attached to the I/O cards in the I/O backplane assembly.

5. Loosen the two captive screws. See Figure 6-24 for the screw locations.
  - a. Press the blue button to release the black knob.
  - b. Turn the black knob counter-clockwise until the captive screw is free from the system board.

**Figure 6-24 Removing the I/O Backplane Assembly**

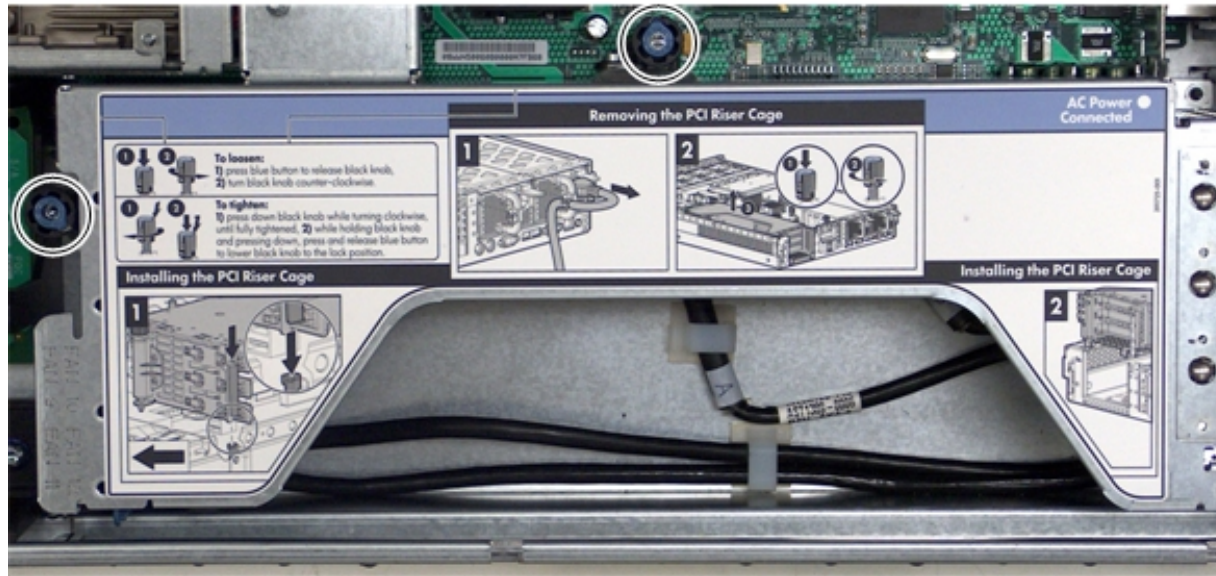

6. Lift the assembly straight up and out of the server. Figure 6-25 (page 168) shows the PCI-X and the PCIe/PCI-X backplane assemblies.

**Figure 6-25 I/O Backplane Assembly Removed**

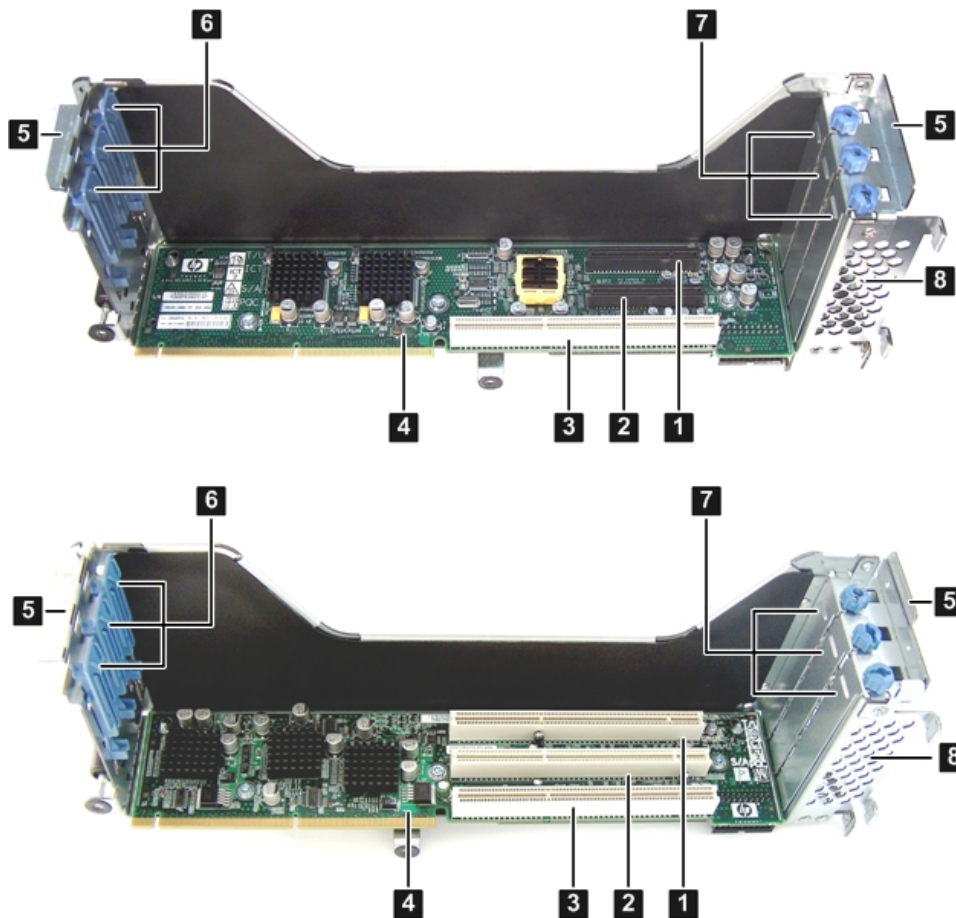

- |  |   |
|--|---|
| <b>1</b> Slot 1 (top, PCIe/PCI-X board; bottom PCI-X board)                    | <b>5</b> Guide tabs                           |
| <b>2</b> Slot 2 (top, PCIe/PCI-X board; bottom PCI-X board)                    | <b>6</b> Gate latches (for full-length cards) |
| <b>3</b> Slot 3 (PCI-X)  | <b>7</b> Bulkhead fillers                     |
| <b>4</b> I/O backplane riser board (top, PCIe/PCI-X board; bottom PCI-X board) | <b>8</b> Sheet metal enclosure                |

## Replacing the I/O Backplane Assembly

To replace the I/O backplane assembly, follow these steps:

1. Transfer any I/O cards from the removed I/O backplane assembly to the replacement I/O backplane assembly.
2. Align the tabs with the guide slots in the server and slide the I/O backplane assembly into place.
3. Tighten the two captive screws. See [Figure 6-24](#).
  - a. Press the black knob down while turning it clockwise until it is fully tightened.
  - b. While holding the black knob and pressing down, press and release the blue button to lower the black knob to the locked position.
4. Replace the top cover. See [“Replacing the Top Cover”](#) (page 144).
5. If rack mounted, slide the server completely into the rack. See [“Inserting the Server into the Rack”](#) (page 143).
6. Connect any external cables to the I/O cards in the I/O backplane assembly.
7. Reconnect the power cables and power on the server. See [“Powering On and Powering Off the Server”](#) (page 78).



## Removing and Replacing a PCI-X/PCIe Card

PCI-X/PCIe cards are located in the I/O backplane assembly. There are three public slots available in the I/O backplane assembly. Removing or installing PCI-X/PCIe cards requires that the server be powered off. Depending on which I/O backplane was purchased, the I/O backplane assembly may contain three PCI-X slots, or a combination of PCI-X and PCIe slots (two PCIe slots, and one PCI-X slot). Figure 6-25 (page 168) shows the PCIe/PCI-X and PCI-X slot locations.

### Removing a PCI-X/PCIe Card

Observe the following warnings and cautions before removing a PCI-X/PCIe card.



**WARNING!** Ensure that the system is powered off and all power sources are disconnected from the server prior to performing this procedure.

Voltages are present at various locations in the server whenever an ac power source is connected. This voltage is present even when the main power switch is in the off position.

Failure to observe this warning can result in personal injury or damage to equipment.



**CAUTION:** Observe all ESD safety precautions before attempting this procedure. Failure to follow ESD safety precautions can result in damage to the server.

Record the slot location of all PCI-X/PCIe cards as they are removed. Depending on the operating system, replacing PCI-X/PCIe cards in a different location might require system reconfiguration.

To remove a PCI-X/PCIe card, follow these steps:

1. Power off the server and disconnect the power cables. See “Powering On and Powering Off the Server” (page 78).
2. If rack mounted, slide the server completely out from the rack. See “Extending the Server from the Rack” (page 142).
3. Remove the top cover. See “Removing the Top Cover” (page 143).
4. Disconnect all internal and external cables attached to the PCI-X/PCIe cards in the I/O backplane assembly.
5. Remove the I/O backplane assembly. See “Removing the I/O Backplane Assembly” (page 166).
6. Remove the slotted T-15 screw that attaches the card bulkhead to the server; use a T-15 driver to turn the screw counter-clockwise until it is free from the server. See Figure 6-24 (page 167).



**NOTE:** Figure 6-25 (page 168) shows both the PCIe/PCI-X I/O backplane and the PCI-X backplane.

7. Pull the gate latch to release the edge of the PCI-X/PCIe card.
8. Grasp the card by the edges and lift it out of the server.

### Installing a PCI-X/PCIe Card

Before installing a PCI-X/PCIe card, ensure that you install the proper drivers for the PCI-X/PCIe card.

To install a PCI-X/PCIe card, follow these steps:

1. Power off the server and disconnect the power cables. See “Powering On and Powering Off the Server” (page 78).
2. If rack mounted, slide the server completely out from the rack. See “Extending the Server from the Rack” (page 142).
3. Remove the top cover from the server. See “Removing the Top Cover” (page 143).

4. Disconnect all internal and external cables attached to the PCI-X/PCIe cards in the I/O backplane assembly.
5. Remove the I/O backplane assembly from the server. See “Removing the I/O Backplane Assembly” (page 166).
6. Select an empty slot that is appropriate for the card you are installing. Depending on the type of board purchased, this is a PCI-X or PCIe card.
7. Remove the PCI-X/PCIe bulkhead filler if required.
8. Insert the replacement card into the card slot.
  - a. Insert the tab at the base of the card bulkhead into the slot in the server.
  - b. Align the card connectors with the slots on the I/O backplane.
  - c. Apply firm, even pressure to both sides of the card until it fully seats into the slot.



---

**CAUTION:** Ensure that you fully seat the card into the slot or the card may fail after power is applied to the slot.

---

9. Close the gate latch to secure the end of the card.
10. Replace the slotted T-15 screw that attaches the card bulkhead to the server; use a T-15 driver to turn the screw clockwise until it tightens to the server.
11. Install the I/O backplane assembly into the server. See “Replacing the I/O Backplane Assembly” (page 168).
12. Connect all internal and external cables to the PCI cards in the I/O backplane assembly.
13. Replace the top cover. See “Replacing the Top Cover” (page 144).
14. If rack mounted, slide the server completely into the rack. See “Inserting the Server into the Rack” (page 143).
15. Reconnect the power cables and power on the server. See “Powering On and Powering Off the Server” (page 78).

## Removing and Replacing the Fan / Display Board

The fan/display board is a combination board that provides and supports the following functionalities:

- Fan power for the server fans
- Power switch and status LEDs
- DVD drive
- Front panel USB port
- Front panel VGA port

The fan/display board contains the power switch and the following status LEDs:

- Power LED
- System health LED
- Internal health LED

- External health LED
- Locator (UID) LED



**WARNING!** Ensure that the system is powered off and all power sources are disconnected from the server prior to performing this procedure.

Voltages are present at various locations in the server whenever an ac power source is connected. This voltage is present even when the main power switch is in the off position.

Failure to observe this warning can result in personal injury or damage to equipment.



**CAUTION:** Observe all ESD safety precautions before attempting this procedure. Failure to follow ESD safety precautions can result in damage to the server.



**NOTE:** The fan/display board includes a USB connector that supports USB 2.0 (480 Mbps) and a VGA connector.

The fan/display board is also the secondary location of the UUID for the server. Do not remove the system board and fan/display board at the same time, or the UUID is deleted from the server.

The procedure for removing the fan/display board for the Data Center server is the same for the Office friendly server.

## Removing the Fan / Display Board

To remove the fan/display board, follow these steps:

1. Power off the server and disconnect the power cables. See “Powering On and Powering Off the Server” (page 78).
2. If rack mounted, slide the server completely out from the rack. See “Extending the Server from the Rack” (page 142).
3. Remove the top cover. See “Removing the Top Cover” (page 143).
4. Remove the server fans in the fan carrier. See “Removing a Server Fan” (page 150).
5. Remove the front fan carrier assembly. See “Removing the Fan Carrier Assembly” (page 161).
6. Disconnect the five cables attached to the fan/display board (1). See Figure 6-26.
7. Turn the captive knurled thumb screws counterclockwise until the screws release from the server (2).
8. Shuttle the board toward the rear of the server until the board keyways clear the server guide pins (3). Tilt the board toward the front of the server, and lift it out at an angle (4).

**Figure 6-26 Removing and Replacing the Fan / Display Board**

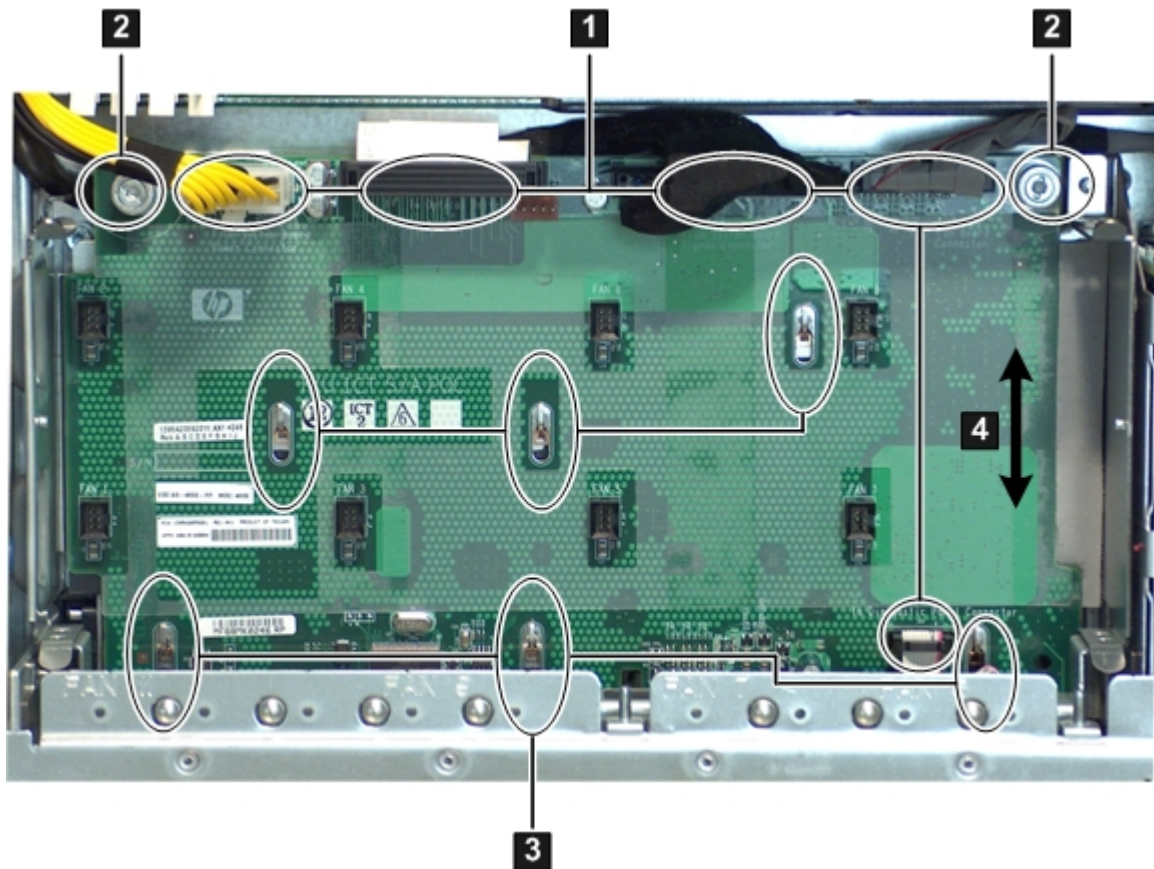

- |  |   |
|--|---|
| <b>1</b> Cables connected to the fan/display board | <b>3</b> Keyways on the fan/display board |
| <b>2</b> Captive thumbscrews                       | <b>4</b> Fan/display board                |



**NOTE:** Figure 6-26 (page 172) shows the Data Center fan/display board. The Office Friendly board is nearly identical.

## Replacing the Fan / Display Board

To replace the fan/display board, follow these steps:

1. Align the connectors with the openings on the front bezel and place the fan/display board onto the guide pins. Shuttle the board toward the front of the server until it locks into place (3).
2. Turn the knurled thumb screws clockwise until the board is secured into place (2).
3. Reconnect the five cables into the connectors on the fan/display board (1).
4. Replace the fan carrier. See “Replacing the Fan Carrier Assembly” (page 163).
5. Replace the top cover. See “Replacing the Top Cover” (page 144).
6. If rack mounted, slide the server completely into the rack. See “Inserting the Server into the Rack” (page 143).

7. Reconnect the power cables and power on the server. See “Powering On and Powering Off the Server” (page 78).



**NOTE:** When replacing the fan/display board you are prompted to copy the primary UUID to the secondary location (**PRI to SEC**). Reply **y**.

## Removing and Replacing System Memory

System memory modules, or DIMMs, are located on the system board.



**WARNING!** Ensure that the system is powered off and all power sources are disconnected from the server prior to performing this procedure.

Voltages are present at various locations in the server whenever an ac power source is connected. This voltage is present even when the main power switch is in the off position.

Failure to observe this warning can result in personal injury or damage to equipment.



**CAUTION:** Observe all ESD safety precautions before attempting this procedure. Failure to follow ESD safety precautions can result in damage to the server.

## Removing System Memory

To remove system memory, follow these steps:

1. Power off the server and disconnect the power cables. See “Powering On and Powering Off the Server” (page 78).
2. If rack mounted, slide the server out from the rack until it stops. See “Extending the Server from the Rack” (page 142).
3. Remove the top cover from the server. See “Removing the Top Cover” (page 143).
4. Remove the airflow guide. See “Removing the Airflow Guide” (page 145).
5. Release the DIMM from the slot.
  - a. Identify on the system board which DIMM you want to remove. See Figure 6-27 for the slot IDs.
  - b. Push the appropriate extraction levers (found on either side of the DIMM slot) outward to the open position.
6. Remove the DIMM from the slot.

Figure 6-27 shows the memory slots on the system board.

**Figure 6-27 Memory Location and Slot IDs**

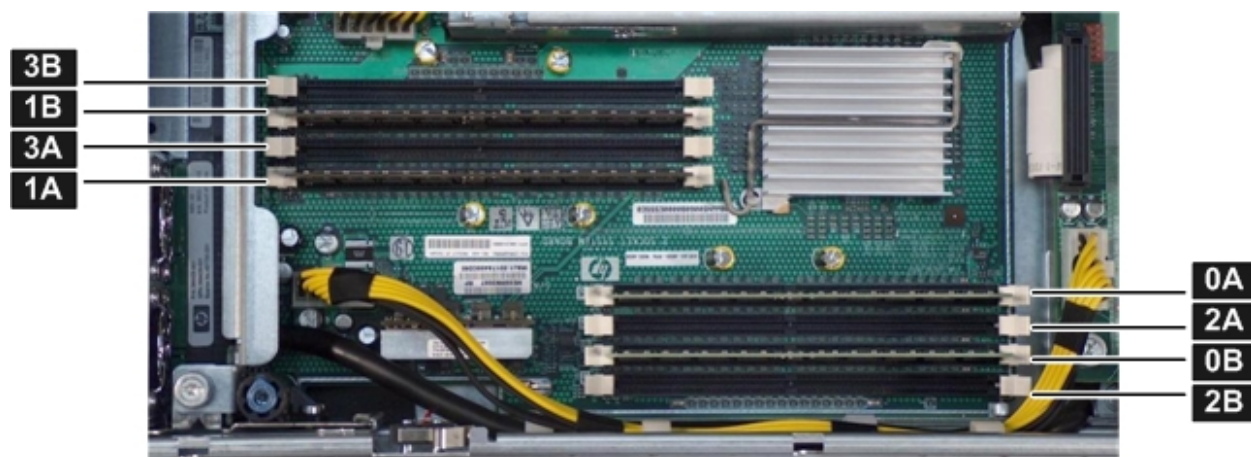

## Memory Installation Conventions

Before installing memory, read and understand the following memory installation conventions:

- Supported DIMM sizes and memory configurations
- DIMM load order
- DIMM slot IDs

### Supported DIMM Sizes

System DIMMs seat onto the memory boards. The minimum server configuration requires at least one memory pair, or group of two DIMMs.

The following are the supported DIMM sizes for the server:

- 512 MB
- 1 GB
- 2 GB
- 4 GB

### Memory Load Order

When installing memory, use a minimum of one pair of like-sized DIMMs. You can install additional DIMMs later. Install DIMMs in the appropriate slots on the system board. Each slot has a unique ID. See Figure 6-27 for the DIMM slot IDs.



**CAUTION:** Failure to observe the following cautions results in system degradation or failure:

- Do not mix DIMM sizes or types in a pair.
- Load DIMM pairs in order of size from largest to smallest. For example, if you are installing a pair of 4-GB DIMMs and a pair of 1 GB DIMMs, install the pair of 4 GB DIMMs first.

Table 6-1 lists the memory load order.

**Table 6-1 Memory Load Order**

Pair Number	Memory Slots
1	0A; 0B
2	1A; 1B
3	2A; 2B
4	3A; 3B

### Memory Loading Rules and Guidelines

Use the following rules and guidelines when installing memory:

- Install DIMMs in pairs
- Ensure all DIMMs pairs are identical
- Install pairs in order of size from largest to smallest
- Install DIMM pairs in the specified order

### Installing Memory

To install memory, follow these steps:

1. Power off the server and disconnect the power cables. See “Powering On and Powering Off the Server” (page 78).
2. If rack mounted, slide the server out from the rack until it stops. See “Extending the Server from the Rack” (page 142).

3. Remove the top cover from the server. See [Removing the Top Cover](#), to remove the top cover, follow these steps: If rack mounted, fully extend the server out from the rack. See [Using the Allen wrench](#), provided on the rear panel of the server, unlock the cover release lever (if necessary) by turning the cam approximately 90 degrees counter-clockwise (1). Pull up on the cover release lever to disengage the top cover from the server (2). Slide the cover toward the rear of the server until the tabs release from the slots in the chassis (3). Lift the cover off the server (4). [Removing the Top Cover](#)
4. Complete the following memory installation prerequisite tasks before installing the memory:
  - a. Determine the DIMM load order. For more information, see [“Memory Load Order”](#) (page 174).
  - b. See [Figure 6-27](#) to determine the DIMM slots to populate.
  - c. Read, understand, and follow the general guidelines to install memory in the server. See [“Memory Loading Rules and Guidelines”](#) (page 174).
5. Install the DIMM by doing the following:
  - a. Align the DIMM with the slot located on the memory board, and align the key in the connector with the notch in the DIMM.
  - b. Firmly and evenly push on each end of the DIMM until it seats into the slot.
  - c. Ensure the extraction levers are in the fully closed position.
6. Verify the DIMM installation by using the one of the following system utilities:
  - `iLO 2 MP DF` command
  - `EFI info mem` command
7. Replace the airflow guide. See [“Replacing the Airflow Guide”](#) (page 147)
8. Replace the top cover. See [“Replacing the Top Cover”](#) (page 144).
9. If rack mounted, slide the server completely into the rack. See [“Inserting the Server into the Rack”](#) (page 143).
10. Reconnect the power cables and power on the server. See [“Powering On and Powering Off the Server”](#) (page 78).

## Removing and Replacing a Processor

The server uses single- or dual-core processors. A single-core processor contains one core, while a dual-core processor contains two cores that function as separate processors. Dual-core processors double the processing power of the server while maintaining the physical dimensions of a single processor.

Table 6-2 lists the supported processor configurations in the server.

**Table 6-2 Supported Processor Configurations**

Configuration	Processor Type	Number of Installed Processors	Number of Cores	Number of Logical Processors (Hyperthreading on)
1 P / 1 C	Single-core	1	1	2
1 P / 2 C	Dual-core	1	2	4
2 P / 2 C	Single-core	2	2	4
2 P / 4 C	Dual-core	2	4	8



**WARNING!** Ensure that the system is powered off and all power sources are disconnected from the server prior to performing this procedure.

Voltages are present at various locations in the server whenever an ac power source is connected. This voltage is present even when the main power switch is in the off position.

Failure to observe this warning can result in personal injury or damage to equipment.



**CAUTION:** Ensure that processor speeds and cache sizes are identical for all processors. Failure to observe this caution causes performance degradation or system failure.

The easiest way to ensure processor compatibility is to use processors with identical part numbers.

**CAUTION:** Observe all ESD safety precautions before attempting this procedure. Failure to follow ESD safety precautions can result in damage to the server.

## Processor Load Order

The server supports up to two processors on the processor board. The slots on the processor board are labeled CPU 0 and CPU 1. In single-processor servers, you must install the processor in the CPU 0 slot. In dual-processor servers, you must install the second processor in the CPU 1 slot.

Table 6-3 lists the processor load sequence.

**Table 6-3 Processor Load Order**

Processor	Slot
1	CPU 0
2	CPU 1

## Required Tools

To install and remove processors, use the processor install tool fastened to the airflow guide.

## Removing a Processor

To remove a processor, follow these steps:

1. Power off the server and disconnect the power cables. See “Powering On and Powering Off the Server” (page 78).
2. If rack mounted, slide the server out from the rack until it stops. See “Extending the Server from the Rack” (page 142).
3. Remove the top cover. See “Removing the Top Cover” (page 143).
4. Remove the airflow guide. See “Removing the Airflow Guide” (page 145).
5. Open the processor cage.
  - a. Grasp the processor cage handle and apply adequate force to rotate the handle upward. See Figure 6-28.
  - b. Use the handle to rotate the cage closure approximately 90 degrees toward the front of the server until it stops. See Figure 6-29.



**IMPORTANT:** Ensure the processors are entirely exposed and can clear the cage enclosure for removal.

6. Disconnect the processor power cable from the connector cable attached to the system board. See Figure 6-30.
7. Unlock the processor from the socket on the processor board. See Figure 6-31.



- a. Unfasten the processor installation tool (2.5 mm driver) from the tool holder on the airflow guide.
- b. Insert the processor tool into the hole on the side of the heatsink.
- c. Rotate the processor tool counter-clockwise 180 degrees.



**CAUTION:** The processor zero insertion force (ZIF) socket is locked and unlocked by turning the processor tool *half* of a full turn. The counter-clockwise 180 degree rotation (half turn) unlocks the socket. A clockwise 180 degree rotation locks the socket. Attempting to turn the locking mechanism more than 180 degrees can severely damage the socket.

- d. Refasten the processor install tool (2.5 mm driver) to the tool holder on the airflow guide.
8. Remove the processor from the processor slot.
  - a. Carefully grasp the sheet metal that encases the processor.
  - b. Pull the processor straight up and out of the server.
9. Protect the processor from damage.
  - a. Install the protective pin cover on the processor connectors to shield the connector pins.
  - b. Place the processor in an anti-static container.

Figure 6-28 shows how to open the processor cage.

#### Figure 6-28 Opening and Closing the Processor Cage

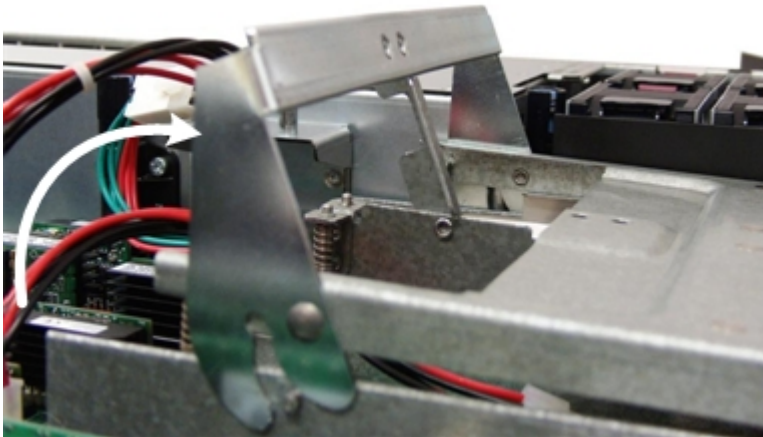

Figure 6-29 shows the processor cage open.

**Figure 6-29 Processor Cage Open**

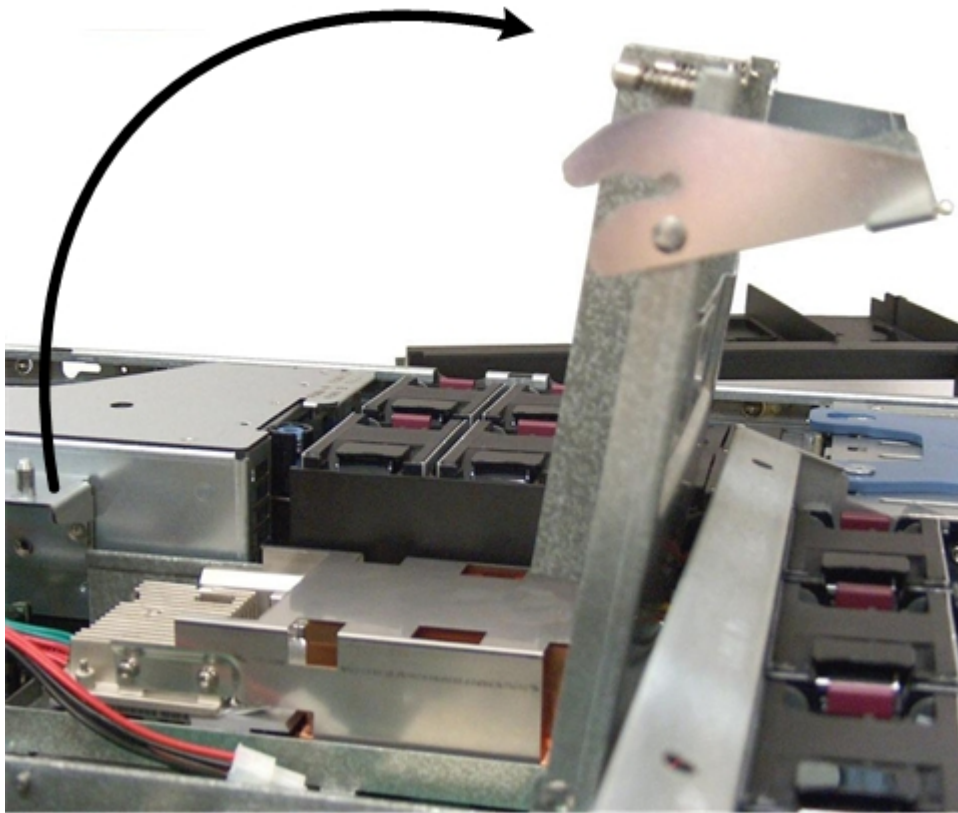

Figure 6-30 shows the power connector and cable for the processor.

**Figure 6-30 Processor Power Connectors and Cables**

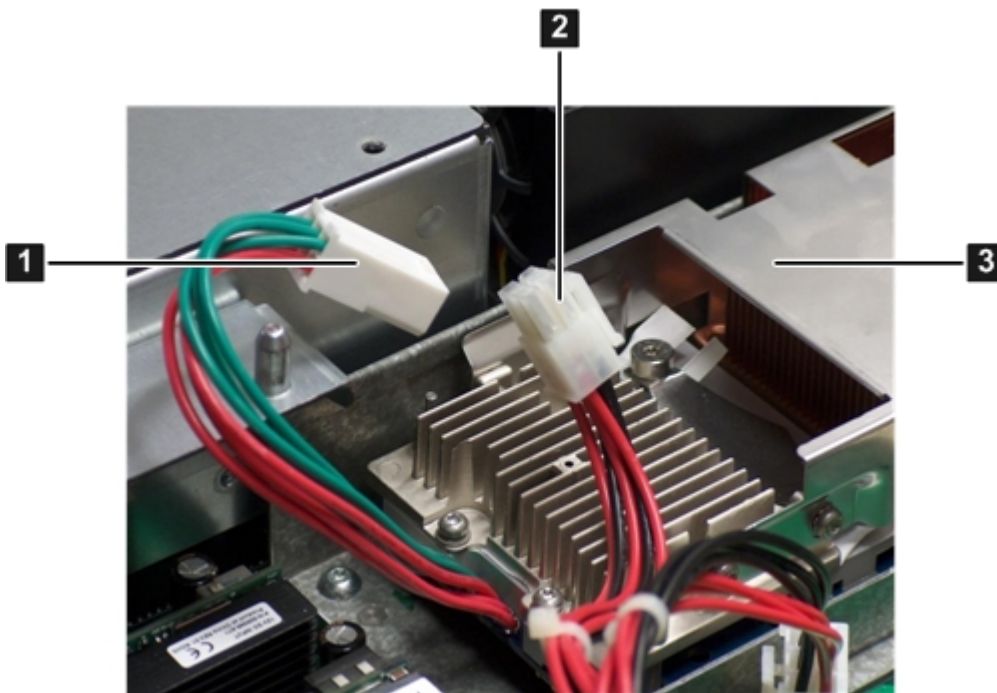
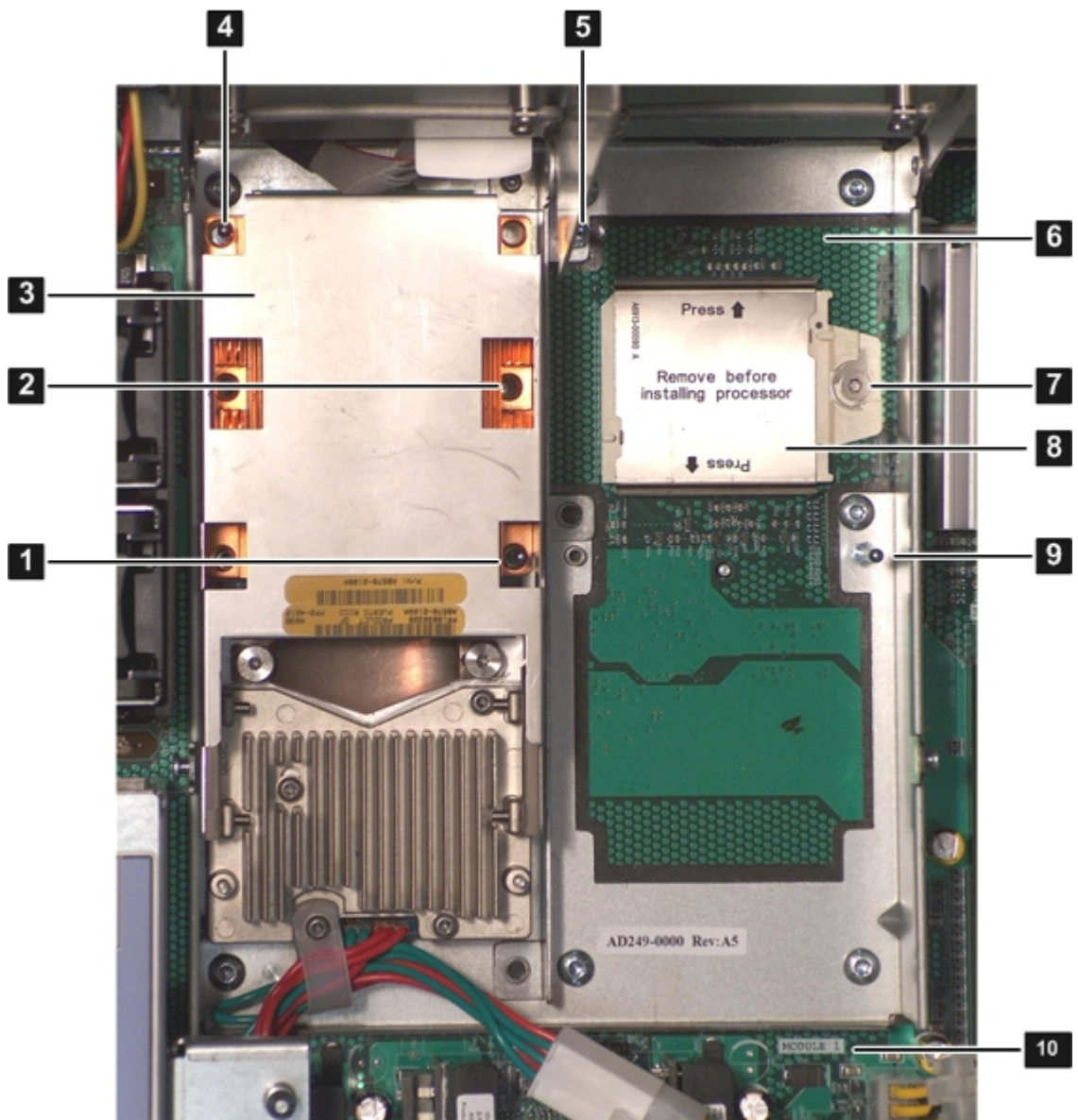

Figure 6-31 shows the processor ZIF socket location and the alignment holes of an installed processor.

- 1** Power connector on the processor
- 2** Power cable from the system board
- 3** Processor

Figure 6-31 Processor ZIF Socket, and Alignment Holes and Posts



- |          |                                  |           |                                   |
|----------|----------------------------------|-----------|-----------------------------------|
| <b>1</b> | Alignment hole on processor      | <b>6</b>  | Processor slot 1                  |
| <b>2</b> | ZIF socket for processor 0       | <b>7</b>  | ZIF socket for processor 1        |
| <b>3</b> | Processor 0 (in slot 0)          | <b>8</b>  | Processor slot 1 dust cover       |
| <b>4</b> | Alignment hole on processor      | <b>9</b>  | Alignment post on processor cage  |
| <b>5</b> | Alignment post on processor cage | <b>10</b> | Processor 1 slot label (module 1) |

Figure 6-32 shows the ZIF socket in the unlocked position.

**Figure 6-32 ZIF Socket**

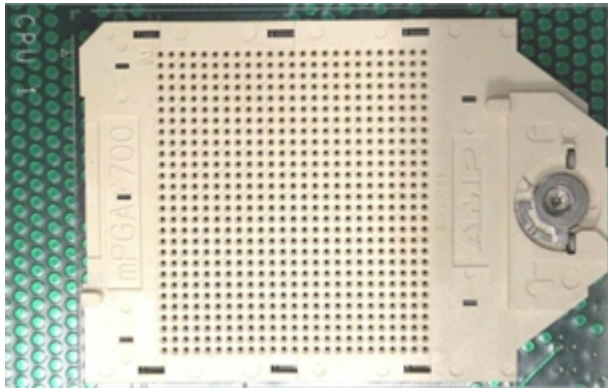

## Installing a Processor



**NOTE:** Prior to installing a processor into the server, read the following instructions carefully and refer to the figures in this chapter for a complete understanding of this process.

To install a processor, follow these steps:

1. Power off the server and disconnect the power cables. See “Powering On and Powering Off the Server” (page 78).
2. If rack mounted, slide the server out from the rack until it stops. See “Extending the Server from the Rack” (page 142).
3. Remove the top cover. See “Removing the Top Cover” (page 143).
4. Remove the airflow guide (if not already done). See “Removing the Airflow Guide” (page 145).
5. Open the processor cage (if not already done). See Figure 6-28.
  - a. Grasp the processor cage handle, and apply adequate force to rotate the handle upward.
  - b. Use the handle to rotate the cage closure approximately 90 degrees toward the front of the assembly until it stops. See Figure 6-29.



**IMPORTANT:** Ensure the processor slot is entirely exposed. The processor must clear the cage enclosure for proper installation.

6. Locate the appropriate processor slot (CPU 0 or CPU 1) for the processor installation. See Figure 6-31 for the slot locations on the system board.
7. Remove the plastic airflow blocker covering the processor slot (if necessary).
8. Remove the protective dust cover from the processor socket (if necessary).
9. Ensure the cam on the processor ZIF socket is in the unlocked, counterclockwise position. See Figure 6-32.



**CAUTION:** The processor zero insertion force (ZIF) socket is locked and unlocked by turning the processor tool *half* of a full turn. The counter-clockwise 180 degree rotation (half turn) unlocks the socket. A clockwise 180 degree rotation locks the socket. Attempting to turn the locking mechanism more than 180 degrees can severely damage the socket.

10. Remove any protective packaging from the processor.



**NOTE:** Protective covers are installed to protect connector pins. Save the covers for future use.

11. Inspect the processor pins, and verify the pins are not bent.

12. Align the alignment holes on the processor with the alignment posts on the processor cage, and carefully lower the processor onto the processor socket. See Figure 6-31.

---

 **CAUTION:** Do not press the processor into the socket. When properly aligned, the processor pins seat into the socket. No additional pressure is required. Damage to the pins can occur if pressure is applied.

---

13. Lock the processor into the socket on the processor board. See Figure 6-31.
  - a. Unfasten the processor install tool (2.5 mm driver) from the tool holder on the airflow guide.
  - b. Insert the processor tool into the hole on the side of the heatsink.
  - c. Rotate the processor tool clockwise 180 degrees.

---

 **CAUTION:** The processor zero insertion force (ZIF) socket is locked and unlocked by turning the processor tool *half* of a full turn. The counter-clockwise 180 degree rotation (half turn) unlocks the socket. A clockwise 180 degree rotation locks the socket. Attempting to turn the locking mechanism more than 180 degrees can severely damage the socket.

---

- d. Fasten the processor install tool (2.5 mm driver) to the tool holder on the airflow guide.
14. Connect the processor power cable into the connector cable that attaches directly to the processor board. See Figure 6-30.
15. Close the processor cage. See Figure 6-29.
  - a. Grasp the processor cage handle and rotate the cage closure inward toward the rear of the assembly until it is completely closed.
  - b. Apply adequate force to push the handle down until it is flush with the cage.
16. Replace the airflow guide. See “Replacing the Airflow Guide” (page 147).
17. Replace the top cover. “Replacing the Top Cover” (page 144).
18. If rack mounted, slide the server completely into the rack. See “Inserting the Server into the Rack” (page 143).
19. Reconnect the power cables and power on the server. See “Powering On and Powering Off the Server” (page 78).
20. Verify processor replacement and operation by using the system utilities.
  - Use the `iLO 2 MP SS` command to verify operation
  - Use the `EFI info cpu` command to verify operation

# Removing and Replacing the Power Supply Housing

The power supplies seat into a housing that attaches to the system board through the power supply riser board.

**WARNING!** Ensure that the system is powered off and all power sources are disconnected from the server prior to performing this procedure.

Voltages are present at various locations in the server whenever an ac power source is connected. This voltage is present even when the main power switch is in the off position.

Failure to observe this warning can result in personal injury or damage to equipment.

**CAUTION:** Observe all ESD safety precautions before attempting this procedure. Failure to follow ESD safety precautions can result in damage to the server.

## Removing the Power Supply Housing

To remove the power supply housing, follow these steps:

1. Power off the server and disconnect the power cables. See “Powering On and Powering Off the Server” (page 78).
2. If rack mounted, slide the server completely out from the rack. See “Extending the Server from the Rack” (page 142).
3. Remove the top cover. See “Removing the Top Cover” (page 143).
4. Loosen the three captive screws shown in Figure 6-33 (page 182).
  - a. Press the blue button to release the black knob.
  - b. Turn the black knob counterclockwise until the captive screw is free from the system board.
5. Lift the power supply housing straight up and out of the server.



**NOTE:** The power supply riser board comes out as part of the power supply housing.

**Figure 6-33 Removing the Power Supply Housing**

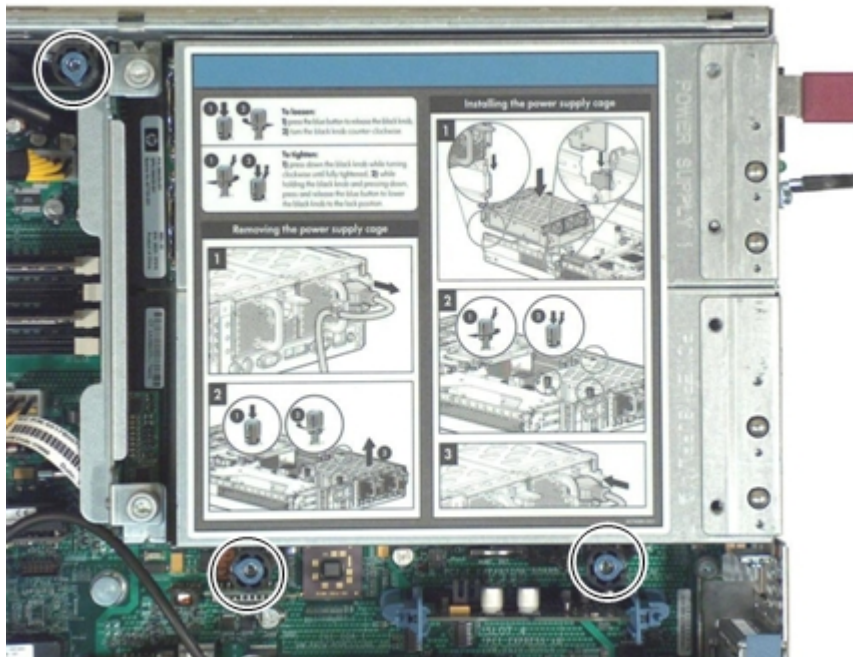

**Figure 6-34 Power Supply Housing Removed From the Server**

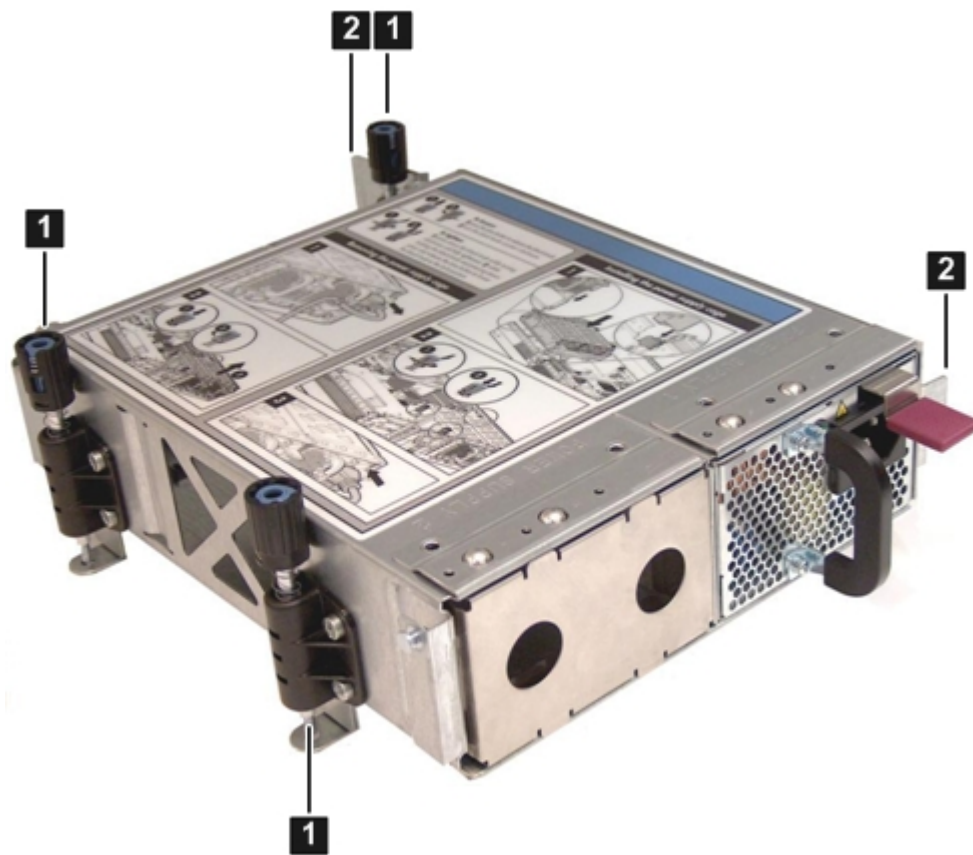

- 1** Captive screws                      **2** Guide tabs

## Replacing the Power Supply Housing

To replace the power supply housing, follow these steps:

1. Insert the tabs on the power supply housing into the server guide slots and align the BPS riser board with the connector on the system board. Set the power supply housing into place.
2. Tighten the three captive screws.
  - a. Press the black knob down while turning it clockwise until it is fully tightened.
  - b. While holding the black knob and pressing down, press and release the blue button to lower the black knob to the locked position.
3. Replace the top cover. See “Replacing the Top Cover” (page 144).
4. If rack mounted, slide the server completely into the rack. See “Inserting the Server into the Rack” (page 143).
5. Reconnect the power cables and power on the server. See “Powering On and Powering Off the Server” (page 78).

# Removing and Replacing the Power Supply Riser Board

The power supply riser board attaches the power supplies to the system board.



**WARNING!** Ensure that the system is powered off and all power sources are disconnected from the server prior to performing this procedure.

Voltages are present at various locations in the server whenever an ac power source is connected. This voltage is present even when the main power switch is in the off position.

Failure to observe this warning can result in personal injury or damage to equipment.



**CAUTION:** Observe all ESD safety precautions before attempting this procedure. Failure to follow ESD safety precautions can result in damage to the server.

## Removing the Power Supply Riser Board

To remove the power supply riser board, follow these steps:

1. Power off the server and disconnect the power cables. See “Powering On and Powering Off the Server” (page 78).
2. Remove the power supplies from the server. See “Removing a Power Supply” (page 153).
3. If rack mounted, slide the server completely out from the rack. See “Extending the Server from the Rack” (page 142).
4. Remove the top cover. See “Removing the Top Cover” (page 143).
5. Turn the two knurled thumb screws shown in Figure 6-35 (page 184) counter-clockwise until the screws are free from the system board.
6. Lift the power supply riser board straight up to disengage it from the slot on the system board and out of the server.

**Figure 6-35 Power Supply Riser Board**

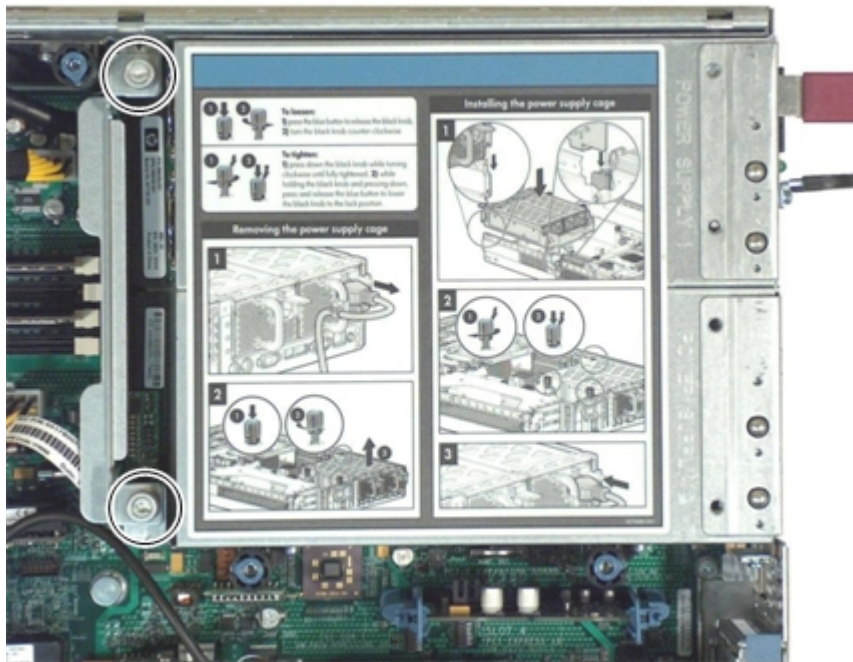

## Replacing the Power Supply Riser Board

To replace the power supply riser board, follow these steps:

1. Align the power supply riser board connector with the socket on the system board.



2. Insert the power supply riser board into the slot and use firm, even pressure to seat the board.
3. Turn the knurled thumb screws clockwise until the power supply riser board tightens to the power supply housing.
4. Replace the top cover. See “Replacing the Top Cover” (page 144).
5. If rack mounted, slide the server completely into the rack. See “Inserting the Server into the Rack” (page 143).
6. Replace the power supplies. See “Replacing a Power Supply” (page 154).
7. Reconnect the power cables and power on the server. See “Powering On and Powering Off the Server” (page 78).

## Removing and Replacing the System and iLO 2 MP Battery

The system and iLO 2 MP batteries are located on the system board. Replace the battery with only the identical or equivalent battery. Follow the manufacturer’s recommendations. Dispose of used batteries according to the manufacturer’s instructions.



**WARNING!** Lithium batteries can explode if mistreated. Do not recharge, disassemble, or dispose of the battery in a fire. Failure to observe this warning can result in personal injury or damage to equipment.

## Removing the System or iLO 2 MP Battery



**WARNING!** Ensure that the system is powered off and all power sources are disconnected from the server prior to performing this procedure.

Voltages are present at various locations in the server whenever an ac power source is connected. This voltage is present even when the main power switch is in the off position.

Failure to observe this warning can result in personal injury or damage to equipment.



**CAUTION:** Observe all ESD safety precautions before attempting this procedure. Failure to follow ESD safety precautions can result in damage to the server.



**IMPORTANT:** Before removing the system battery, record all boot and LAN configuration settings (find the settings using the `INFO ALL EFI` command). You **must** reset these values after replacing the battery. You can also use the non-volatile RAM configuration backup (NVRAM) backup utility to back up and store these values. The utility is located at:

<http://www.hp.com/go/bizsupport.com>

Before removing the iLO 2 MP battery, see the *HP Integrity Integrated Lights Out 2 Management Processor Operations Guide* for backing up iLO 2 MP configuration settings.

To remove and replace the system or iLO 2 MP battery, follow these steps:

1. Power off the server and disconnect the power cables. See “Powering On and Powering Off the Server” (page 78).
2. Locate the system or iLO 2 MP battery mounted vertically on the system board. See Figure 6-36.
3. Insert a flat tool under the battery retaining clip and carefully push it away from the battery. Lift the battery from the socket.

**Figure 6-36 System and iLO 2 MP Battery Locations**

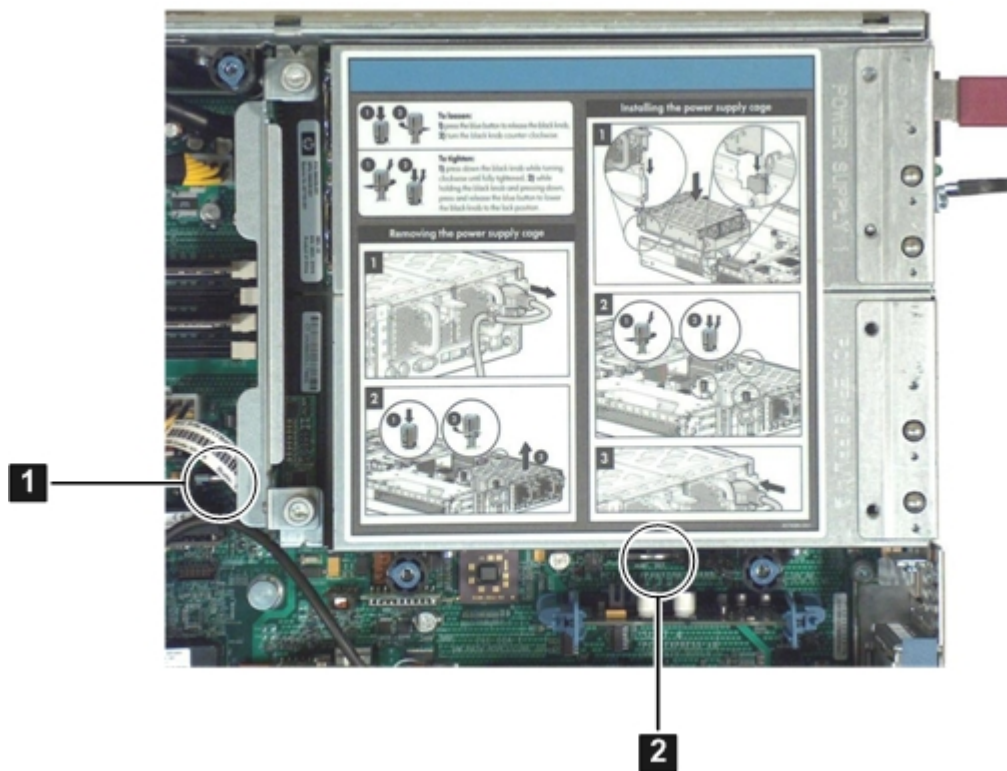

**1** System battery

**2** iLO 2 MP battery

## Replacing the System or iLO 2 MP Battery

To replace the system or iLO 2 MP battery, follow these steps:

1. Insert the replacement battery into the socket on the system board.



**NOTE:** The positive terminal of the battery is designated by the + sign.

2. Replace the top cover. “Replacing the Top Cover” (page 144).
3. Reconnect the power cables and power on the server. See “Powering On and Powering Off the Server” (page 78).
4. Restore the boot, LAN and iLO 2 MP settings using the method you used to back them up.
5. Reset the server date and time using the EFI `date` and `time` commands.

## Removing and Replacing the Trusted Platform Module

The Trusted Platform Module (TPM) is an optional security component which enhances security capabilities for the server if it is running the HP-UX operating system. The TPM is a security chip that is unique to the server. It performs key security processes independent of other hardware components. The TPM creates and stores additional encryption keys from the root key of the system. The encryption keys created by the TPM encapsulate system application encryption keys to provide an additional layer of security for sensitive system data.

The fundamental capabilities of the TPM include:

- Platform authentication
- Sensitive information protection
- Data integrity
- System privacy



---

**IMPORTANT:** You must run the supported version of the HP-UX operating system to utilize the TPM security component.

---



**WARNING!** Ensure that the system is powered off and all power sources are disconnected from the server prior to performing this procedure.

Voltages are present at various locations in the server whenever an ac power source is connected. This voltage is present even when the main power switch is in the off position.

Failure to observe this warning can result in personal injury or damage to equipment.

---



**CAUTION:** Observe all ESD safety precautions before attempting this procedure. Failure to follow ESD safety precautions can result in damage to the server.

---

## Removing the TPM

To remove the TPM, follow these steps:

1. Back up the current TPM settings. See the HP-UX operating system documentation for more information.
  2. Power off the server and disconnect the power cables. See “Powering On and Powering Off the Server” (page 78).
  3. If rack mounted, slide the server completely out from the rack. See “Extending the Server from the Rack” (page 142).
  4. Remove the top cover. See “Removing the Top Cover” (page 143).
  5. Grasp the TPM by the edges and lift it out of the socket on the system board. Figure 6-37 shows the location of the TPM on the system board.
- 



**CAUTION:** If the TPM has failed, destroy the TPM after removing it from the server. Follow local regulations to securely destroy the TPM.

If you use this procedure as part of a system board swap, transfer the TPM from the failed system board to the new system board

---

**Figure 6-37 TPM Location on System Board**

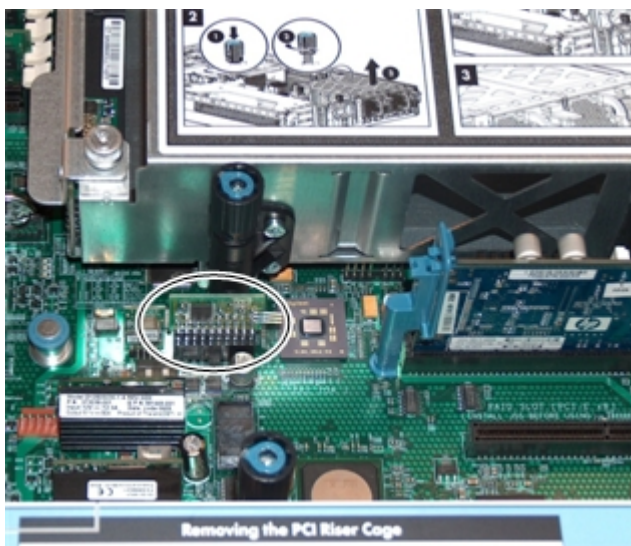

## Replacing the TPM

To replace the TPM, follow these steps:

1. To insert the TPM, follow these steps:
    - a. Align the TPM connector pinouts with the pins on the system board socket.
- 
-  **NOTE:** The female connector on the TPM has one pinout plugged, which aligns with a missing pin on the male connector on the system board.
- 
- b. Push the TPM straight down into the socket until it is fully seated. See Figure 6-37.
  2. Replace the top cover. See “Replacing the Top Cover” (page 144).
  3. If rack mounted, slide the server completely into the rack. See “Inserting the Server into the Rack” (page 143).
  4. Reconnect the power cables and power on the server. See “Powering On and Powering Off the Server” (page 78).
  5. To enable the TPM, follow these steps:
    - a. Access the EFI Shell.
    - b. Enter **info sec** to display the server security settings on the screen. The TPM is disabled by default.
    - c. Enter **secconfig** to display a list of configurable security settings.
    - d. Enter **secconfig tpm on** to enable the TPM.
  6. Reset the server.
  7. Boot the operating system. See Chapter 4 (page 87).
  8. Restore the former TPM settings to the new TPM. See the operating system documentation for more information.
  9. Back up the TPM security information. See the operating system documentation for more information.

## Removing and Replacing the Smart Array P400 Controller and PCIe Expansion Board

The rx2660 server has two slots on the system board for the optional Smart Array P400 controller, and the PCIe expansion board. The PCIe expansion board enables the Smart Array P400 controller slot.



**WARNING!** Ensure that the system is powered off and all power sources are disconnected from the server prior to performing this procedure.

Voltages are present at various locations in the server whenever an ac power source is connected. This voltage is present even when the main power switch is off.

Failure to observe this warning can result in personal injury or equipment damage.



**CAUTION:** Observe all ESD safety precautions before attempting this procedure. Failure to follow ESD safety precautions can result in damage to the server.

## Removing the Optional Smart Array P400 Controller and Battery

To remove the optional Smart Array P400 controller, follow these steps:

1. Power off the server and disconnect the power cables. See “Powering On and Powering Off the Server” (page 78).
2. If rack mounted, slide the server completely out from the rack. See “Extending the Server from the Rack” (page 142).
3. Remove the top cover. See “Removing the Top Cover” (page 143).
4. Disconnect the internal SAS cables attached to the board. See Figure 6-38.

**CAUTION:** When disconnecting the SAS cables, note the labeling on the cables. When reconnecting these cables, match each cable with the appropriate socket on the Smart Array P400 controller. If the cables are mismatched, the server might not reboot. Both cables and sockets are clearly marked with the correct channels.

**Figure 6-38 Smart Array P400 Controller Location on System Board**

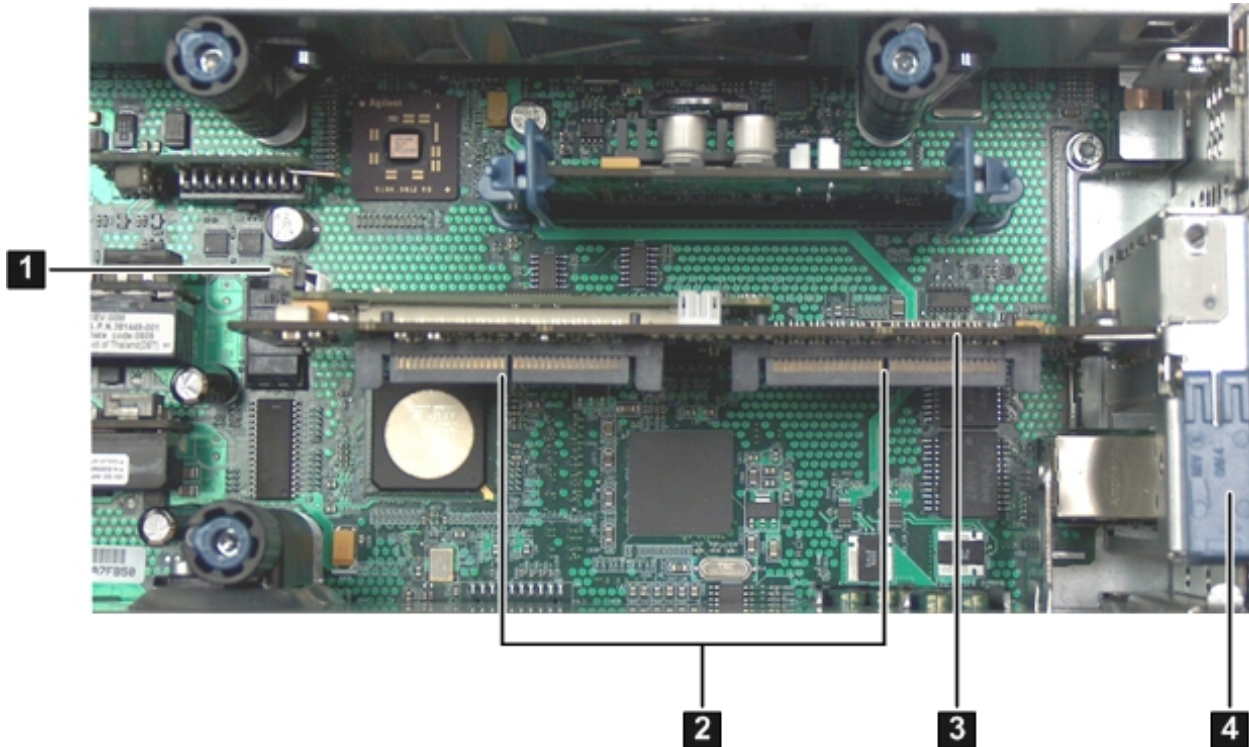

**1** RAID battery port on the SAS Smart Array P400 controller

**2** SAS cable ports on the SAS Smart Array P400 controller

**3** SAS Smart Array P400 controller

**4** SAS Smart Array P400 controller board lock

5. Disconnect the battery cable from the Smart Array P400 controller card.
6. Grasp the card by the edges and lift it out of the server.

7. To remove the battery from the top of the airflow guide, do the following.
  - a. Push the battery retaining clip away from the battery (1) as shown in Figure 6-39.
  - b. Slide the battery to disengage the battery posts from the slots on the airflow guide (2).
  - c. Lift the battery off of the airflow guide.

**Figure 6-39 Removing the Battery from the Airflow Guide**

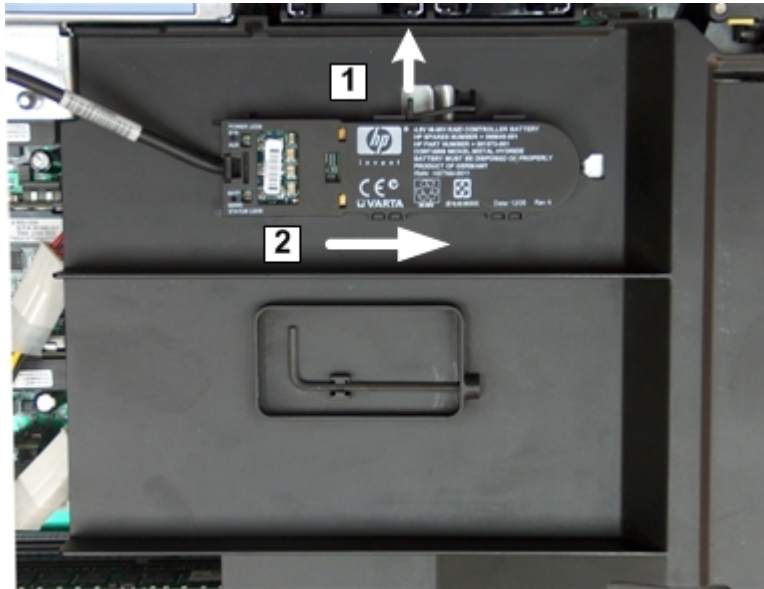

## Removing the PCIe Expansion Board

To remove the PCIe expansion board, follow these steps:

1. Power off the server and disconnect the power cables. See “Powering On and Powering Off the Server” (page 78).
2. If rack mounted, slide the server completely out from the rack. See “Extending the Server from the Rack” (page 142).
3. Remove the top cover. See “Removing the Top Cover” (page 143).
4. Pinch the board rail clips to the sides (1). See Figure 6-40 “Removing the PCIe Expansion Board”.

5. Pull the PCIe expansion board straight up and out of the server (2).

**Figure 6-40 Removing the PCIe Expansion Board**

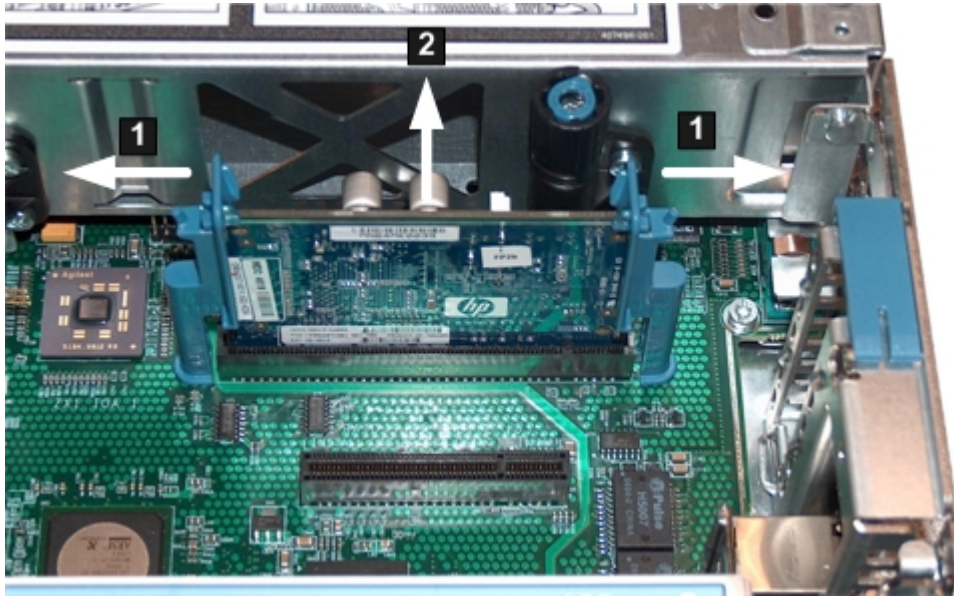

## Replacing the Smart Array P400 Controller Board

To replace the Smart Array P400 controller board, follow these steps:

1. Insert the SAS core I/O Smart Array P400 controller board into the dedicated slot:
  - a. Align the card connector with the slot on the system board.
  - b. Apply firm, even pressure to both sides of the card until it fully seats into the slot.
  - c. Close the SAS core I/O Smart Array P400 controller board lock. See Figure 6-38.

---

**CAUTION:** When reconnecting the SAS cables, note the labeling on the channel cables. Match each cable with the appropriate socket on the SAS core I/O board. If the cables are mismatched, the server will not reboot. Both cables and sockets are clearly marked with the correct channels.

---

2. Reconnect the internal SAS cables to the SAS core I/O Smart Array P400 controller board.
3. To install the battery onto the airflow guide, follow these steps:
  - a. Insert the posts on the battery into the slots on the airflow guide.
  - b. Slide the battery until it clicks into place (1). See Figure 6-41.

**Figure 6-41** Installing the Battery on the Airflow Guide

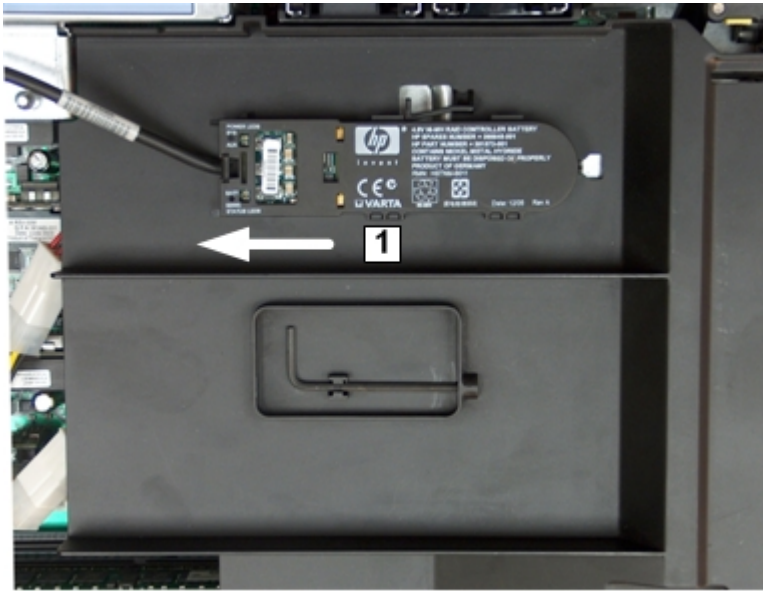

4. Plug the battery cable into the connector on the SAS core I/O RAID board.
5. Replace the top cover, unless you continue with replacing the PCIe expansion board. See “Replacing the Top Cover” (page 144), or proceed to “Replacing the PCIe Expansion Board” (page 192).
6. If rack mounted, slide the server completely into the rack, unless you continue with replacing the PCIe expansion board. See “Inserting the Server into the Rack” (page 143), or proceed to “Replacing the PCIe Expansion Board” (page 192).
7. Reconnect the power cables and power on the server, unless you continue with replacing the PCIe expansion board. See “Powering On and Powering Off the Server” (page 78), or “Replacing the PCIe Expansion Board” (page 192).

## Replacing the PCIe Expansion Board

To replace the PCIe expansion board, follow these steps:

1. Make sure the board rail clip are in the open position.
2. Guide the PCIe expansion board into the rails, and seat the board into the slot on the system board.



---

**NOTE:** The PCIe expansion board and slot are keyed to fit only one way.

---

3. Push the board rail clips toward the PCIe expansion board to lock the board in place.



**Figure 6-42 Installing the PCIe Expansion Board**

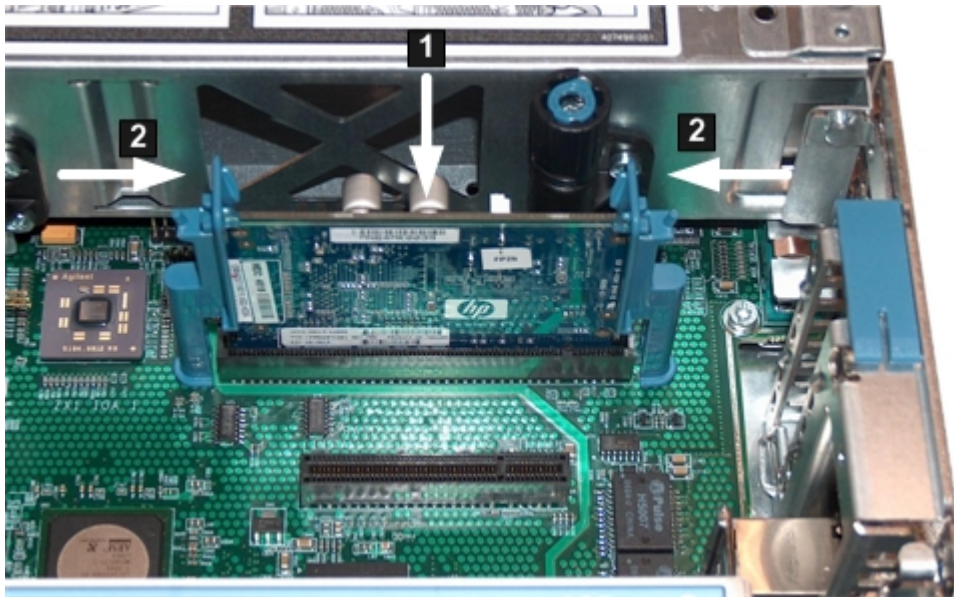

4. Replace the top cover. See “Replacing the Top Cover” (page 144).
5. If rack mounted, slide the server completely into the rack. See “Inserting the Server into the Rack” (page 143).
6. Reconnect the power cables, and power on the server. See “Powering On and Powering Off the Server” (page 78).

## Removing and Replacing the SAS Backplane Board

Serial-attached SCSI (SAS) is a new, faster version of the industry standard SCSI technology. Although SCSI is a proven technology, its parallel data communication model restricts it from providing the speed and scalability that is required for modern data transfer and storage. In a parallel data communication environment, multiple devices share one bus; all data travels over the same cable and through the same port.

SAS provides serial, or point-to-point, data transfer. A point-to-point architecture means that each device has its own private bus, cable, and port. This architecture improves the reliability and availability of data, and greatly enhances data transfer rates. Current data transfer rates are 3 Gb/s. Additional features of the SAS technology include:

- Full-duplex capability (all data reads and writes occur simultaneously).
- Automatic device discovery and configuration (each device is assigned a unique SAS address).
- Thin cables and small connectors (assist with cooling and ease cable management issues).
- Increased scalability (expanders enable support for thousands of SAS devices).

The SAS backplane attaches to an interconnect board that functions as a link between the midplane board and the SAS backplane.

---



**WARNING!** Ensure that the system is powered off and all power sources are disconnected from the server prior to performing this procedure.

Voltages are present at various locations in the server whenever an ac power source is connected. This voltage is present even when the main power switch is off.

Failure to observe this warning can result in personal injury or equipment damage.

---



**CAUTION:** Observe all ESD safety precautions before attempting this procedure. Failure to follow ESD safety precautions can result in damage to the server.

---

## Removing the SAS Backplane Board

To remove the SAS backplane, follow these steps:

1. Power off the server and disconnect the power cables. See “Powering On and Powering Off the Server” (page 78).
  2. If rack mounted, slide the server completely out from the rack. See “Extending the Server from the Rack” (page 142).
  3. Remove the top cover. See “Removing the Top Cover” (page 143).
  4. Slide the SAS drives and fillers approximately two inches out of the drive bays. See “Removing a SAS Hard Drive” (page 155).
- 



**CAUTION:** When disconnecting the SAS cables, note the labeling on the cables. When reconnecting these cables, match each cable with the appropriate socket on the SAS backplane. If the cables are mismatched, the server will not function correctly. Both cables and sockets are clearly marked with the correct channel.

---

5. Disconnect the SAS cables from the connectors on the SAS backplane (1).
6. Disconnect the SAS backplane power cable from the connector on the SAS backplane (2).
7. Pull the release mechanism toward the front of the server to disengage the SAS backplane from the server (3).
8. Lift the SAS backplane off the guide posts on the SAS drive cage (4). Angle the board toward the rear of the server and lift it out of the server.

**Figure 6-43 Removing and Replacing the SAS Backplane**

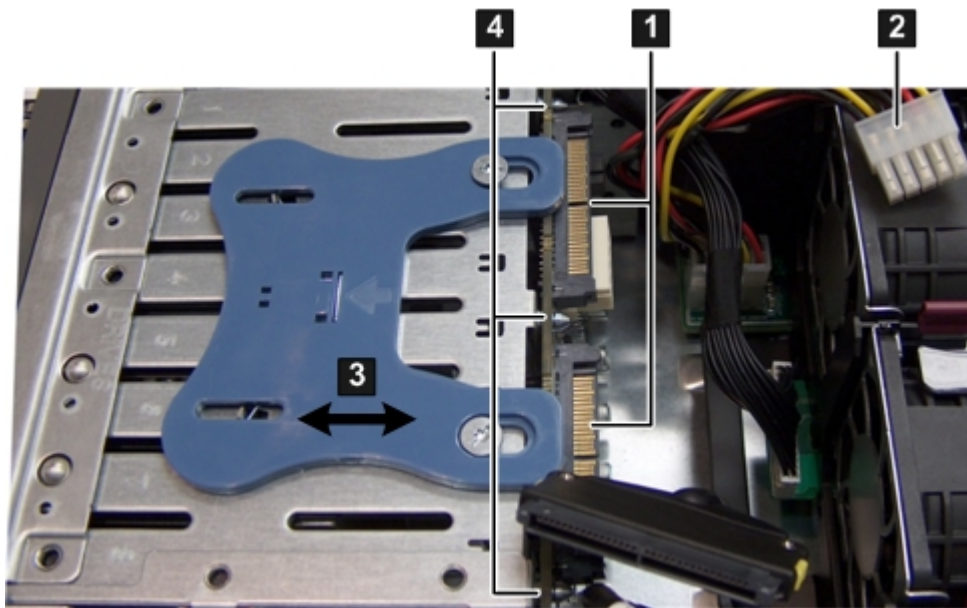

## Replacing the SAS Backplane

To replace the SAS backplane, follow these steps:

1. Pull the release mechanism toward the front of the server and hold it there to allow the SAS backplane to be installed.
2. Align the three keyway slots of the SAS backplane with the guide posts on the disk drive cage and guide the board down until it is flush with the SAS drive cage (4).
3. Let go of the release mechanism to lock the board in place.
4. Reconnect the SAS backplane power cable to the connector on the SAS backplane (2).
5. Reconnect the SAS cables into the connectors on the SAS backplane (1).

**CAUTION:** When reconnecting the SAS cables, note the labeling on the channel cables. Match each cable with the appropriate socket on the SAS backplane. If the cables are mismatched the server will not function correctly. Both cables and sockets are clearly marked with the correct channel.

6. Push the release mechanism toward the back of the server to secure the SAS backplane to the server (3).
7. Replace the SAS disk drives. See “Replacing a SAS Hard Drive” (page 156).
8. Replace the top cover. See “Replacing the Top Cover” (page 144).
9. If rack mounted, slide the server completely into the rack. See “Inserting the Server into the Rack” (page 143).
10. Reconnect the power cables and power on the server. See “Powering On and Powering Off the Server” (page 78).

## Removing and Replacing the System Board

The system board supports the functionality for the following server subsystems and components:

- System management
- Power
- Internal SAS mass storage
- Processors

- Memory
- Supplies power to the other server boards:
  - Fan/display board
  - I/O fan board
  - I/O backplane
  - SAS backplane



**WARNING!** Ensure that the system is powered off and all power sources are disconnected from the server prior to performing this procedure.

Voltages are present at various locations in the server whenever an ac power source is connected. This voltage is present even when the main power switch is in the off position.

Failure to observe this warning can result in personal injury or damage to equipment.



**CAUTION:** Observe all ESD safety precautions before attempting this procedure. Failure to follow ESD safety precautions can result in damage to the server.



**NOTE:** The system board is the primary location of the UUID. The fan/display board is the secondary location of the UUID. Do not remove these components at the same time, or the UUID is deleted.

When replacing the system board you are prompted to copy the secondary UUID to the primary location (**SEC to PRI**). Reply **y**.

## Removing the System Board

To remove the system board, follow these steps:

1. Save your system configuration and iLO 2 MP configuration settings.



**IMPORTANT:** Before removing the system board, record all boot configuration settings (find the settings using the `INFO ALL EFI` command). You **must** reset these values after replacing the battery. Use the `LS EFI` command to gather the LAN configuration information.

You can also use the non-volatile RAM configuration backup (NVRAM) backup utility to back up and store these values. The utility is located on the HP website at:

<http://www.hp.com/go/bizsupport.com>.

For iLO 2 MP configuration settings, see the *HP Integrity Integrated Lights Out 2 Management Processor Operations Guide*.

2. Power off the server and disconnect the power cables. See “Powering On and Powering Off the Server” (page 78).
3. Disconnect all external cables from the server rear panel.
4. If rack mounted, slide the server completely out from the rack. See “Extending the Server from the Rack” (page 142).
5. Remove the top cover. See “Removing and Replacing the Top Cover” (page 143).
6. Remove the fan carrier. See “Removing the Fan Carrier Assembly” (page 161).
7. Remove the airflow guide. See “Removing the Airflow Guide” (page 145).
8. Remove the memory. See “Removing System Memory” (page 173).
9. Remove the processors. See “Removing a Processor ” (page 176).
10. Remove the power supply housing. See “Removing the Power Supply Housing” (page 182).
11. Remove the I/O backplane assembly. See “Removing the I/O Backplane Assembly” (page 166).

12. Disconnect the internal SAS cables attached to the system board (if necessary). See Figure 6-44.

**CAUTION:** When disconnecting the SAS cables, note the labeling on the cables. When reconnecting these cables, match each cable with the appropriate socket on the SAS core I/O card. If the cables are mismatched, the server may not reboot. Both the cables and the sockets are clearly marked with the correct channel.

**NOTE:** The cables connect directly to the system board for a non-RAID configuration, and connect to the Smart Array P400 controller board for a RAID configuration.

13. Remove the Trusted Platform module (if necessary). See “Removing the TPM” (page 187).
14. Disconnect the power cable that attaches the Smart Array P400 controller board to the battery on the airflow guide (if necessary).
15. Remove the Smart Array P400 controller backplane and the PCIe expansion card (if necessary).
16. Remove the I/O fan carrier. See “Removing the I/O Fan Carrier Assembly” (page 164).
17. Disconnect the cables that attach to the system board (1). See Figure 6-44.
18. Pull up on the post in the center of the system board to unlock it from the server chassis. See Figure 6-44.
19. Shuttle the system board toward the front of the server until the board keyways clear the server guide pins. Tilt the system board toward the rear of the server and lift it out at an angle from the server to remove it.

**Figure 6-44 Removing and Replacing the System Board**

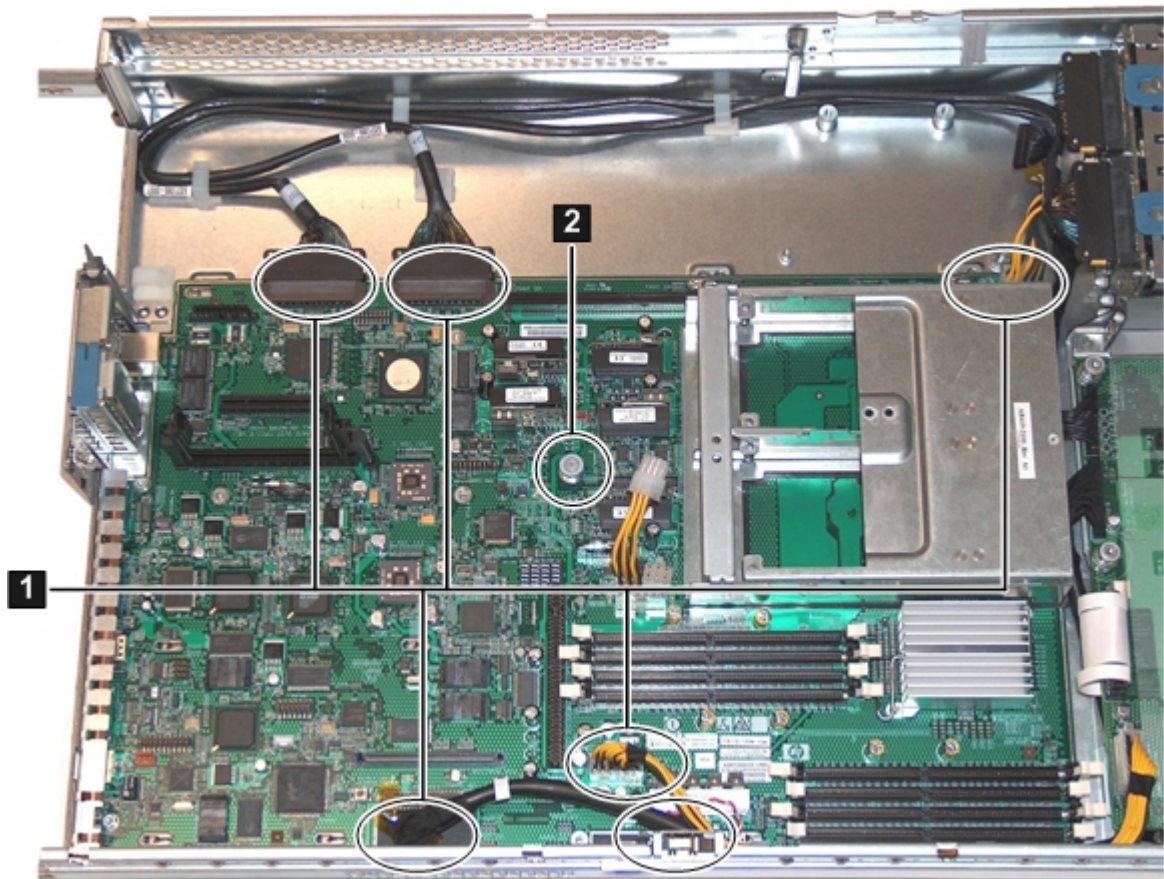

- 1** System board connections    **2** System board unlocking post



---

**NOTE:** If the optional Smart Array P400 controller and PCIe expansion boards are installed in your server, the SAS cables will not be plugged into the system board as shown in Figure 6-44 (page 197).

---

## Replacing the System Board

---



**CAUTION:** When replacing an Office Friendly system board, you must use system board part number AB419-69004 or the server will not power on. It shuts down with an overtemp condition due to multiple fan failures. The following error displays for all of the fans:

```
Log Entry 4: 14 Feb 2007 16:52:21
Alert Level 5: Critical
Keyword: COOLING_UNIT_FAILURE
Cooling unit failure
Logged by: Baseboard Management Controller;
Sensor: Cooling Device - Fan 1 (Mem)
Data1: transition to Critical from less severe 0x2045D33E45020050 FFFF0207210A0300
```

---

To replace the system board, follow these steps:

1. Insert the new system board with the back of the system board going into the server first. Guide the system board onto the guide pins, and slide the system board into the keyways.



---

**NOTE:** When replacing the system board you are prompted to copy the secondary UUID to the primary location (**SEC to PRI**). Reply **y**. (

---

2. Reconnect the cables that attach to the system board (1). See Figure 6-44.
3. Replace the I/O fan carrier. See “Replacing the I/O Fan Carrier Assembly” (page 166).
4. Reconnect the power cable that attaches to the SAS backplane.
5. Replace the Smart Array P400 controller backplane and PCIe expansion card (if necessary).
6. Reconnect the power cable that attaches to the Smart Array P400 controller backplane and the PCIe expansion card (if necessary).
7. Reconnect the internal SAS cables.



---

**CAUTION:** When reconnecting the SAS cables, match each cable with the appropriate socket on the SAS core I/O card. If the cables are mismatched, the server may not reboot. Both cables and sockets are clearly marked with the correct channel.

---



---

**NOTE:** The cables connect directly to the system board for a non-RAID configuration, and connect to the Smart Array P400 controller for a RAID configuration.

---

8. Replace the TPM. See “Replacing the TPM” (page 187).
9. Replace the I/O card cage. “Replacing the I/O Backplane Assembly” (page 168).
10. Replace the power supply cage. See “Replacing the Power Supply Housing” (page 183).
11. Replace the processors. See “Installing a Processor” (page 180).
12. Replace the memory. See “Installing Memory” (page 174).
13. Replace the airflow guide. See “Replacing the Airflow Guide” (page 147).
14. Replace the fan carrier assembly. “Replacing the Fan Carrier Assembly” (page 163).
15. Replace the top cover. See “Replacing the Top Cover” (page 144).
16. If rack mounted, slide the server completely into the rack. See “Inserting the Server into the Rack” (page 143).

17. Reconnect all cables and power on the server. See “Powering On and Powering Off the Server” (page 78).
18. Restore boot, LAN, and iLO 2 MP settings recorded in step Step 1 of the procedure, see “Removing the System Board” (page 196) when prompted by the server.

---

# A Customer Replaceable Units Information

This appendix provides the following information for each field replaceable unit:

- Manufacturing part number
- Description
- Replacement part number
- Exchange part number

This appendix addresses the following topics:

- “Parts Only Warranty Service” (page 200)
- “Customer Self Repair” (page 200)
- “Customer Replaceable Units List” (page 201)

## Parts Only Warranty Service

Your HP Limited Warranty may include a parts only warranty service. Under the terms of parts only warranty service, HP will provide replacement parts free of charge. For parts only warranty service, CSR part replacement is mandatory. If you request HP to replace these parts, you will be charged for the travel and labor costs of this service.

## Customer Self Repair

repair time and allow for greater flexibility in performing defective parts replacement. If during the diagnosis period HP (or HP service providers or service partners) identifies that the repair can be accomplished by the use of a CRU part, HP will ship that part directly to you for replacement. There are three categories of CRU parts:

- |          |   |
|----------|---|
| Yes      | Parts for which customer self repair is mandatory. If you request HP to replace these parts, you will be charged for the travel and labor costs of this service.  |
| Optional | Parts for which customer self repair is optional. These parts are also designed for customer self repair. If, however, you require that HP replace them for you, there may or may not be additional charges, depending on the type of warranty service designated for your product. |
| No       | Some HP parts are not designed for customer self repair. To satisfy the customer warranty, HP requires that an authorized service provider replace the part.  |

Based on availability and where geography permits, CRU parts are shipped for next business day delivery. Same-day or four-hour delivery may be offered at an additional charge where geography permits. If assistance is required, you can call the HP Technical Support Center and a technician will help you over the telephone.

HP specifies in the materials shipped with a replacement CRU part whether a defective part must be returned to HP. In cases where it is required to return the defective part to HP, you must ship the defective part back to HP within a defined period of time, normally five (5) business days. The defective part must be returned with the associated documentation in the provided shipping material. Failure to return the defective part may result in HP billing you for the replacement. With a CRU, HP pays for all the shipping and part return costs and determines the courier to be used.

For more information about HP's Customer Self Repair program, contact your local service provider. For the North American program, refer to the HP website at:

<http://www.hp.com/go/selfrepair>

Table A-1 provides customer self repair information.



**Table A-1 Customer Self Repair Information**

Code	Level	Description	Comments
AY	Yes	Level A with instructions available in the service guide	Requires you to replace these parts under warranty. No technical skills required.
BY	Optional	Level B with instructions available in the service guide	Low to moderate technical skills required.
CY	Optional	Level C with instructions available in the service guide	High technical skills required.
N	No	Not a customer replaceable part.	Some HP parts are not designed for customer self repair. In order to satisfy the customer warranty, HP requires that an authorized service provider install or replace the part.

## Customer Replaceable Units List

Table A-2 lists the customer replaceable units (CRUs) of the HP Integrity rx2660 server.

**Table A-2 HP Integrity rx2660 CRU List**

Manufacturing Part Number	Description	Replacement Part Number	Exchange Part Number	Customer Self Repair
<b>Processors</b>				
AD252-2100D AD252AX	CPU module, 1.4 GHz / 12 MB dual-core	AD252-2100D	AD252-6900A	BY
AH237-2100A AH237AX	CPU module, 1.4 GHz / 12 MB dual-core <sup>1</sup>	AH237-2100A	AH237-6900A	BY
AD249-2103D AD249AX	CPU module, 1.6 GHz / 6 MB single-core	AD249-2103D	AD249-6900A	BY
AH236-2100A AH236AX	CPU module, 1.6 GHz / 6 MB single-core <sup>1</sup>	AH236-2100A	AH236-6900A	BY
AH238-2100A AH238AX	CPU module, 1.6 GHz / 18 MB dual-core <sup>1</sup>	AH238-2100A	AH238-6900A	BY
AD392-2100B AD392AX	CPU, 1.6GHz/12MB, single core	AD392-2100B	AD392-6900A	BY
AD390-2100B AD390AX	CPU, 1.42GHz/12MB, dual core	AD390-2100B	AH240-6900A	BY
AD391-2100B AD391AX	CPU, 1.67GHz/18MB, dual core	AD391-2100B	AH241-6900A	BY
<b>Memory (DIMMs)</b>				
AB563-6001A	512 MB DIMM	AD326A	AB563-69001	BY
AB564-6001A	1 GB DIMM	AD327A	AB564-69001	BY
AB565-6001A	2 GB DIMM	AD328A	AB565-69001	BY
AB566-6001A	4 GB DIMM	AD329A	AB566-69001	BY
<b>Boards</b>				
AB419-60001	System board	AB419-67001	AB419-69001	CY
AB419-60001	System board <sup>1</sup>	AB419-67024	AB419-69004	CY

**Table A-2 HP Integrity rx2660 CRU List (continued)**

Manufacturing Part Number	Description	Replacement Part Number	Exchange Part Number	Customer Self Repair
AB419-60002	I/O backplane assembly, PCI-X	AB419-67002	AB419-69002	BY
AB419-60003	I/O backplane assembly, PCIe / PCI-X	AB419-67003	AB419-69003	BY
AB419-60010	SAS backplane	AB410-67010	n/a	BY
AB419-60005	System Insight Display (Diagnostic Panel)	AB419-67005	n/a	BY
380622-001	Bulk power supply	403781-001	n/a	AY
379123-001	Bulk power supply <sup>1</sup>	AB419-67023	n/a	AY
399428-001	Bulk power supply riser	407750-001	n/a	BY
314581-003	TPM module	406059-001	n/a	N / CY <sup>2</sup>
AB419-60004	Display/fan board	AB419-67004	n/a	BY
AB419-60011	Display/fan board, Office Friendly	AB419-67019	n/a	BY
AB419-60009	I/O fan board	AB419-67009	n/a	AY
AB419-60012	I/O fan board, Office Friendly	AB419-67020	n/a	AY
<b>Internal Disks/Removable Media</b>				
375863-001	36 GB SAS hard drive	376596-001		AY
375863-002	72 GB SAS hard drive	376597-001		AY
431959-B21	146 GB SAS hard drive	432320-001	432320-001	AY
168003-9D5	DVD drive	397928-001	n/a	AY
AD143-2100A	DVD+RW drive	AD143-2100A	n/a	AY
<b>Add-On I/O Cards</b>				
AB620-60503	Audio card	AB620-60503	n/a	BY
<b>RAID</b>				
AB419-60008	PCI expansion board	AB419-67008	n/a	BY
012760-001	Smart array P400 controller	405831-001	n/a	BY
012764-004	Smart array P400 controller cache module, 256 MB	405836-001	n/a	BY
381573-001	Smart array P400 controller battery module	398648-001	n/a	BY
408658-001	Smart array P400 controller battery cable assembly, 11.5 in.	409124-001	n/a	BY
<b>Fans</b>				
394035-001	Fan assembly	407747-001	n/a	AY
6070B0178401	Fan assembly, Office Friendly	AB419-67021	n/a	AY
<b>Cables</b>				
n/a	Cable kit Includes the following cables: <ul style="list-style-type: none"> <li>Fan/display signal cable</li> <li>Diagnostic panel to display/fan board signal cable</li> <li>I/O fan board to display/fan board signal cable</li> </ul>	AB419-67012	n/a	BY

**Table A-2 HP Integrity rx2660 CRU List (continued)**

Manufacturing Part Number	Description	Replacement Part Number	Exchange Part Number	Customer Self Repair
	<ul style="list-style-type: none"> <li>• DVD signal cable</li> <li>• SAS power cable</li> <li>• Display/fan board to system board power cable</li> <li>• CPU power cable</li> <li>• Intrusion switch and cable</li> </ul>			
n/a	SAS cable	AB419-67013	n/a	AY
<b>Miscellaneous</b>				
394028-003	Bezel	AB419-67014	n/a	AY
394037-001	Top cover	AB419-67015	n/a	AY
6070B0176101	Top cover, Office Friendly	AB419-67022	n/a	AY
376383-002	SAS disk filler panel	376383-002	n/a	AY
229567-001	DVD filler panel	229567-001	n/a	AY
n/a	Airflow guide (with hex tool)	AB419-67016	n/a	AY
AB463-3440A	CPU air blocker	AB463-3440A	n/a	AY
1420-0356	PDH battery (CR2032)	1420-0356	n/a	AY

1 Required for Office Friendly servers, and compatible with Data Center servers

2 N = new install; CY = with a system board replacement



**IMPORTANT:** The list of part numbers above is current and correct as of November 2007. Part numbers change often. Check the <http://partsurfer.hp.com/cgi-bin/spi/main> website to ensure you have the latest part numbers associated with this server.

Use the part nomenclature from this list to select the correct part from the HP Partsurfer.

---

# B Upgrades

This appendix address the following topics:

- “Upgrading the I/O Backplane” (page 204)
- “Processor Upgrades” (page 210)

## Upgrading the I/O Backplane

This section details how to upgrade the I/O backplane assembly from a PCI-X to a PCI-X/PCIe back plane assembly, and includes the following sections:

- “I/O Backplane Upgrade Overview” (page 204)
- “Upgrading the I/O Backplane” (page 205)
- “Upgrade Verification” (page 209)

## I/O Backplane Upgrade Overview

This section shows you how to upgrade the I/O backplane from a PCI-X I/O backplane to a PCI-X/PCIe I/O backplane. Table B-1 provides a comparison of the I/O slots and speeds for the two backplanes.

**Table B-1 Slot Speed Comparison**

Slot Number	PCI-X I/O Backplane	PCI-X / PCIe I/O Backplane
1	PCI-X 266 MHz	PCIe x8
2	PCI-X 133 MHz	PCIe x8
3	PCI-X 266 MHz	PCI-X 133 MHz



**IMPORTANT:** If you are planning to move the PCI-X card in slot 3 of the PCI-X backplane to slot 3 of the PCI-X/PCIe backplane, be aware of the following:

- Slot 3 of the PCI-X backplane runs at 266 MHz; slot 3 of the PCI-X/PCIe backplane runs at 133 MHz. The card runs at the slower speed if used in slot 3 of the PCI-X/PCIe backplane.
- The hardware path to slot 3 changes from the PCI-X backplane to the PCI-X/PCIe backplane. You are required to make configuration changes to enable this card in slot 3 of the PCI-X/PCIe backplane.

If disks are attached to a host bus adapter (HBA) in slot 3, use the HP-UX volume group command set (using the `thvgexport` command) to export data prior to installing the hardware upgrade. On the subsequent server boot, import the data (using the `vgimport` command) to the drives in their new locations.

SUSE Linux users should consider using `Persistent Device Names` before installing the upgrade. For more information, see the appropriate Operating System documentation.

---

## Required Service Tools

Service of this server requires one or more of the following tools:

- Electrically Conductive Field Service Grounding Kit
- ACX-15 Torx screwdriver

## Safety Information

Use care to prevent injury and equipment damage removing and replacing server components. Voltages can be present within the server. Many assemblies are sensitive to damage by electrostatic discharge (ESD).

Follow the safety conventions listed below to ensure safe handling of components, to prevent injury, and to prevent damage to the server:

---

 **CAUTION:** Observe all ESD safety precautions before attempting this procedure. Failure to follow ESD safety precautions can result in damage to the server.

---

- When removing or installing any server component, follow the instructions provided in this guide.
  - If installing an assembly that is neither hot-swappable nor hot-pluggable, disconnect the power cable from the external server power receptacle.
- 

 **WARNING!** Ensure that the server is powered off and all power sources are disconnected from the server prior to removing or installing server hardware.

Voltages are present at various locations within the server whenever an ac power source is connected. This voltage is present even when the main power switch is turned off.

Failure to observe this warning can result in personal injury or damage to equipment.

---

- Do not wear loose clothing that can snag or catch on the server or on other items.
  - Do not wear clothing subject to static charge buildup, such as wool or synthetic materials.
  - If installing an internal assembly, wear an antistatic wrist strap and use a grounding mat, such as those included in the Electrically Conductive Field Service Grounding Kit.
  - Handle accessory boards and components by the edges only. Do not touch any metal-edge connectors or any electrical components on accessory boards.
- 

 **WARNING!** To reduce the risk of personal injury from hot surfaces, allow the internal server components to cool before touching them.

---

## Upgrading the I/O Backplane

Use these procedures to upgrade the I/O backplane assembly from a PIC-X I/O backplane to a PCI-X/PCIe I/O backplane. The I/O backplane assembly consists of the I/O backplane board and a sheet metal enclosure. The PCI-X I/O backplane board contains three full-length public PCI-X I/O slots.

### Performing a Server Backup

Record the boot configuration settings. To find the settings, use the `INFO ALL` EFI Shell command.

---

 **TIP:** Running the `info io` command from the EFI Shell allows you to record the device codes, given in HEX, for your I/O devices. This may be helpful in verifying I/O cards after the upgrade.

---

### Powering Off the Server

1. Shut down the operating system. See [Chapter 4 \(page 87\)](#).
2. Power off the server. See [“Powering Off the Server” \(page 79\)](#)

### Accessing the Server

1. There are two mounting configurations for the server; pedestal mounted, and rack mounted. Use one of the following procedures, depending on the your mounting configuration:
  - [“Accessing a Rack Mounted Server” \(page 142\)](#)
  - [“Accessing a Pedestal Mounted Server” \(page 143\)](#)
2. Remove the top cover. See [“Removing the Top Cover” \(page 143\)](#)

## Removing the I/O Backplane Assembly From the Server

Observe the following warning and cautions before removing the I/O backplane assembly.



**CAUTION:** Observe all ESD safety precautions before attempting this procedure. Failure to follow ESD safety precautions may result in damage to the server.

Record the slot location of all PCI cards as they are removed. The only compatible slot across the two I/O backplanes is the PCI-X 133 MHz slot. If you have more than one PCI-X card in your rx2660 server, it needs to be upgraded to a PCIe card. If you use a 266 MHz card in a 133 MHz slot, the card runs at the lower speed.

To remove the I/O backplane assembly, follow these steps:

1. Disconnect any cables attached to the I/O cards in the I/O backplane assembly.
2. Loosen the two captive screws that hold the I/O backplane assembly to the system board. See Figure B-1 for the screw locations.
  - a. Press the blue button to release the black knob.
  - b. Turn the black knob counterclockwise until the captive screw is free from the system board.

**Figure B-1 I/O Backplane Assembly Screw Locations**

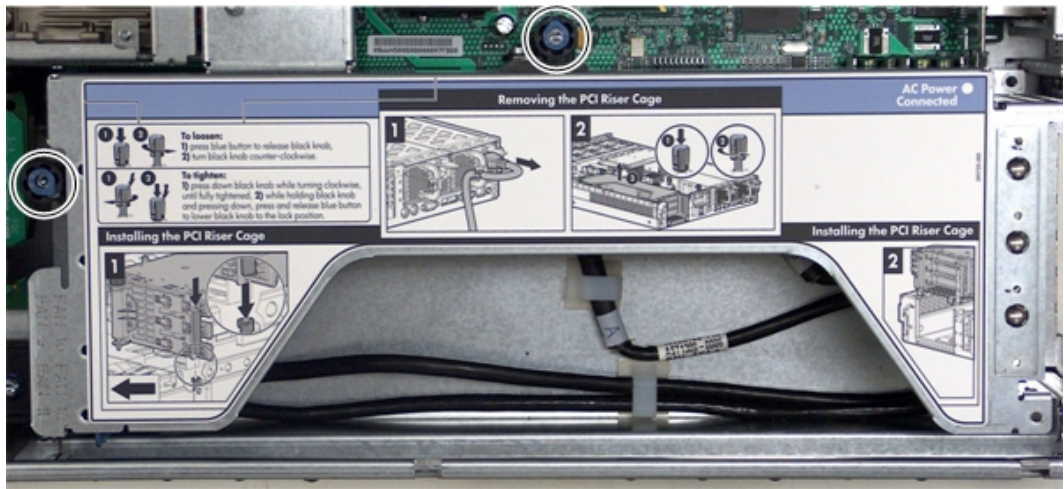

3. Lift the assembly straight up and out of the server. Figure B-2 (page 207) shows the PCI-X I/O backplane assembly.
4. Remove the PCI-X cards from the I/O backplane assembly by doing the following:
  - a. Remove the bulkhead T-15 thumbscrews from the I/O backplane assembly.
  - b. Pull the cards up and out of the I/O backplane assembly.

**Figure B-2 Removing the I/O Backplane Assembly**

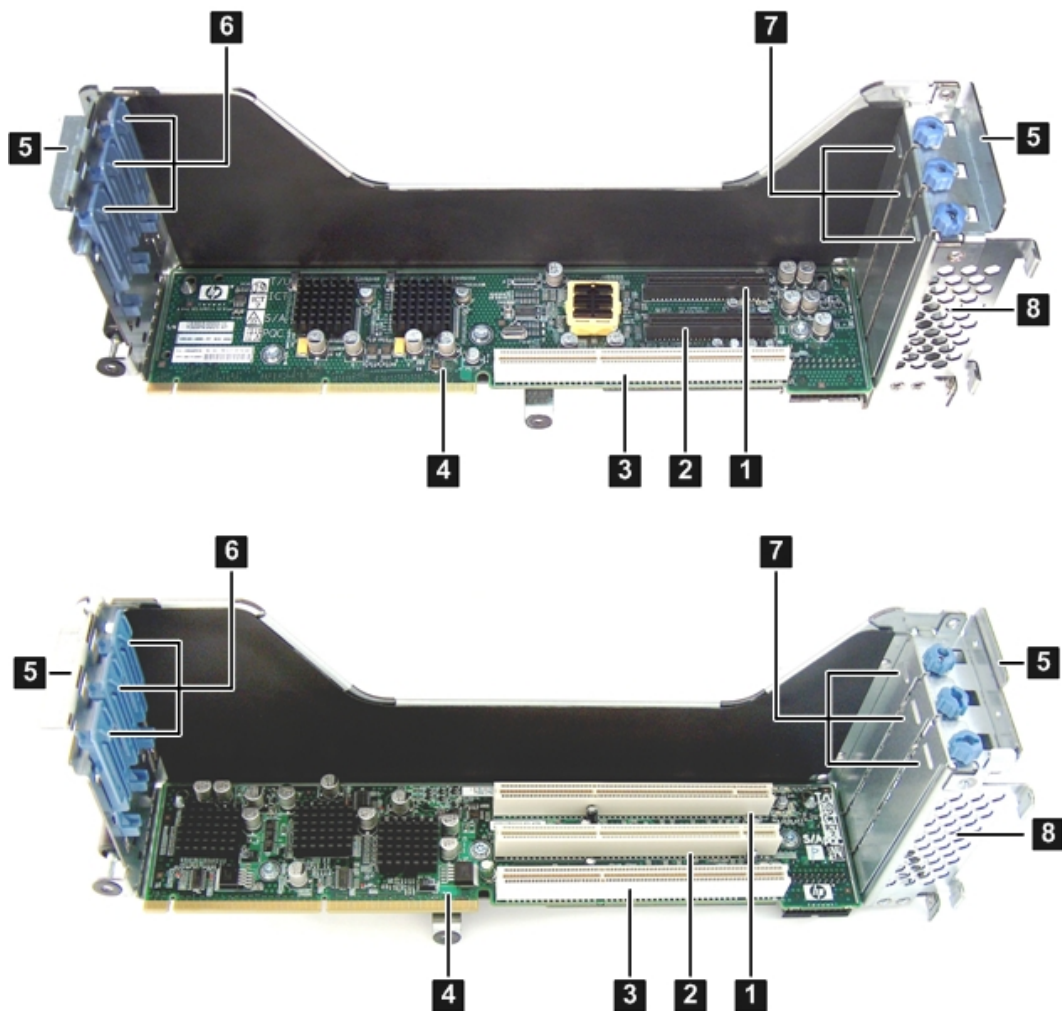

- |          |                                   |           |                                      |
|----------|-----------------------------------|-----------|--------------------------------------|
| <b>1</b> | Slot 1 (266 MHz)                  | <b>6</b>  | Gate latches (for full-length cards) |
| <b>2</b> | Slot 2 (133 MHz)                  | <b>7</b>  | Bulkhead fillers                     |
| <b>3</b> | Slot 3 (266 MHz)                  | <b>8</b>  | Sheet metal enclosure                |
| <b>4</b> | I/O backplane                     | <b>9</b>  | I/O backplane T-15 screws            |
| <b>5</b> | I/O backplane assembly guide tabs | <b>10</b> | Bulkhead T-15 thumbscrews            |

### Removing the PCI-X I/O Backplane Board from the I/O Backplane Assembly

Use this procedure to remove the I/O backplane from the I/O backplane assembly.

1. Remove the three T-15 screws that attach the PCI-X backplane to the I/O backplane assembly. [Figure B-2](#) (page 207) shows the locations of the T-15 screws.
2. Slide the PCI-X backplane down to release it from the posts on the I/O backplane assembly, and lift it from the I/O backplane assembly. [Figure B-3](#) (page 208) shows the locations of the posts on the I/O backplane assembly.

**Figure B-3 I/O Backplane Removed**

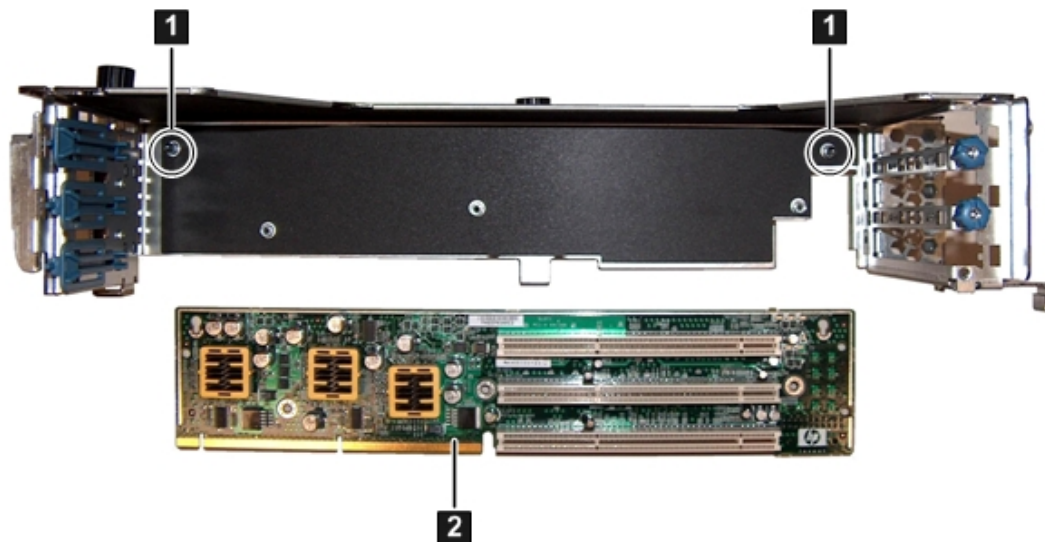

- 1** I/O backplane posts      **2** PCI-X I/O backplane

3. Place the PCI-X I/O backplane in a static-free bag.

### Installing the PCI-X/PCIe I/O Backplane Board Into the I/O Backplane Assembly

Use this procedure to install the I/O backplane into the I/O backplane assembly.

1. Align the PCI-X/PCIe I/O board keyways with the posts on the I/O backplane assembly. [Figure B-4 \(page 208\)](#) shows the locations of the posts on the I/O backplane assembly.
2. Slide the I/O backplane up to lock it onto the I/O backplane assembly posts.

**Figure B-4 Installing the PCI-X/PCIe I/O Backplane**

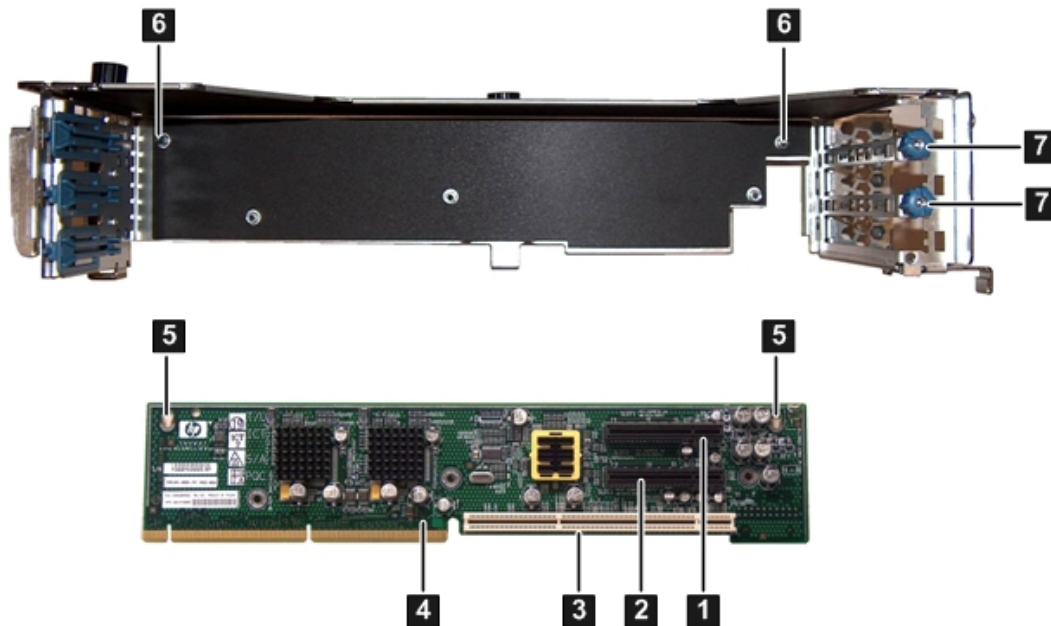

- 1** Slot 1 (PCIe x8)      **5** PCI-X/PCIe I/O backplane keyways  
**2** Slot 2 (PCIe x8)      **6** I/O backplane posts  
**3** Slot 3 (PCI-X 133 MHz)      **7** Bulkhead T-15 thumbscrews  
**4** PCI-X/PCIe I/O backplane

3. Install and tighten the three T-15 screws to attach the I/O board to the I/O backplane assembly



4. Insert the I/O cards into the I/O card slots on the I/O backplane by doing the following:
  - a. Insert the tab at the base of the card bulkhead into the slot on the I/O backplane.
  - b. Align the card connectors with the slots on the I/O backplane.
  - c. Apply firm, even pressure to both sides of the card until it fully seats into the slot.
  - d. Install and tighten the bulkhead T-15 thumbscrew to secure the I/O card to the I/O backplane assembly.



---

**CAUTION:** Ensure that you fully seat the card into the slot or the card may fail after power is applied to the slot.

---

## Replacing the I/O Backplane Assembly Into the Server

To replace the I/O backplane assembly into the server, follow these steps:

1. Align the tabs with the guide slots in the server and slide the I/O backplane assembly into place.
2. Press down evenly on the I/O backplane assembly to seat the I/O backplane into the connector on the system board.
3. Tighten the two captive screws. See [Figure B-1](#).
  - a. Press the black knob down while turning it clockwise until it is fully tightened.
  - b. While holding the black knob and pressing down, press and release the blue button to lower the black knob to the locked position.

## Replacing the Top Cover

For instructions on replacing the top cover, see “[Replacing the Top Cover](#)” (page 144).

## Installing the Server Into the Rack

For instructions on inserting the server back into the rack, see “[Inserting the Server into the Rack](#)” (page 143).

## Installing the Server Into a Pedestal

To install the server back into the pedestal, follow these steps:

1. Align the posts on the pedestal side piece with the slots in the pedestal, and slide the side piece flush with the rest of the pedestal.
2. Tighten the thumb screws on the rear of the server pedestal piece to attach it to the server.
3. Stand the server up on its side with the pedestal feet slots on the bottom.
4. Install the four pedestal kit feet by pushing them into the slots.

## Powering On the Server

For instructions on powering on the server, see “[Powering On the Server](#)” (page 78)

## Upgrade Verification

### Viewing Warnings

To view warnings, access the EFI Shell and run the `info warning` command.

### Verifying I/O cards

To verify the I/O cards, access the EFI Shell and run the `info io` command.

```
Shell> info io
I/O INFORMATION

BOOTABLE DEVICES
Order  Media Type  Path
-----  -
```

```

1   CDROM          Acpi (HWP0002, PNP0A03, 0) /Pci (2|1) /Usb (0, 0) /CDROM (Entry0) /HD (Part1, Sig00000000)
2   HARDDRIVE
Acpi (HWP0002, PNP0A03, 400) /Pci (2|0) /Sas (Addr5000C5000034749D, Lun0) /HD (Part1, Sig4EE76936-BE45-47FA-9AC7-B0ECF2D912F2)

3   HARDDRIVE
Acpi (HWP0002, PNP0A03, 400) /Pci (2|0) /Sas (Addr5000C50000347735, Lun0) /HD (Part1, Sig92C8CB4C-E0F2-11DA-8002-D6217B60E588)

4   HARDDRIVE
Acpi (HWP0002, PNP0A03, 400) /Pci (2|0) /Sas (Addr5000C50000347735, Lun0) /HD (Part3, Sig92C8CB7E-E0F2-11DA-8004-D6217B60E588)

```

```

Seg  Bus  Dev  Fnc  Vendor  Device  Slot
#    #    #    #    ID      ID      #    Path
---  ---  ---  ---  ---     ---     ---  ---
00   00   01   00   0x103C  0x1303  XX   Acpi (HWP0002, PNP0A03, 0) /Pci (1|0)
00   00   01   01   0x103C  0x1302  XX   Acpi (HWP0002, PNP0A03, 0) /Pci (1|1)
00   00   01   02   0x103C  0x1048  XX   Acpi (HWP0002, PNP0A03, 0) /Pci (1|2)

```

```

Fast initialization: Enabled
System Wake-On-LAN: Disabled

```

Shell>

Devices, such as USB ports, that do not occupy a slot are referenced as being in slot XX. Slots that do not contain an I/O card are not be listed in the output. Using the output, confirm that a device detected in each slot that is populated.

## Booting the Operating System

For instructions on booting to the operating system, see [Chapter 4 \(page 87\)](#).

## Processor Upgrades

The HP Integrity rx2660 server supports upgrades from Intel Itanium Montecito to Intel Itanium Montvale processors.



**CAUTION:** Intel Montvale processors cannot be intermixed with similar Montecito processors. Processor speed and cache size must be identical for all processors in a system. To ensure compatibility whether upgrading, replacing, or adding an additional processor, use processors with identical part numbers.

Failure to observe this caution results in performance degradation or system failure.

To ensure compatibility, use processors with identical part numbers.

Table B-2 lists the processor upgrades that are supported, and required system firmware levels for each server.

**Table B-2 Processor Upgrades**

Manufacturing Part Number	Processor	System Firmware Level
<b>HP Integrity rx2660 server</b>		
AD392-2100B AD392AX	1.6 GHz / 12 MB / Single Core	greater than 01.05
AD390-2100B AD390AX	1.42 GHz / 12 MB / Dual Core	
AD391-2100B AD391AX	1.67 GHz / 18 MB / Dual Core	
<b>HP Integrity rx3600 server</b>		
AD390-2100C AD390AX	1.42 GHz / 12 MB	greater than 02.03
AD391-2100C AD391AX	1.67 GHz / 18 MB	
<b>HP Integrity rx6600 server</b>		
AD388-2100C	1.6 GHz / 24 MB	greater than 02.03
AD389-2100C	1.6 GHz / 18 MB	
AD390-2100C AD390AX	1.42 GHz / 12 MB	
<b>HP Integrity BL860c server blade</b>		

**Table B-2 Processor Upgrades** (continued)

Manufacturing Part Number	Processor	System Firmware Level
AD394-2101C	1.42 GHz / 12 MB	greater than 01.01
AD395-2102C	1.6 GHz / 6 MB	
AD396-2101C	1.67 GHz / 18 MB	

## Upgrading Verses Adding On

If your HP Integrity server already contains one, or more, of the processors listed in Table B-2, then follow the processor removal and replacement procedures (see “Removing and Replacing a Processor” (page 175)) to add another processor. Updating the firmware and OS is unnecessary when adding another processor.

If your HP Integrity server does not currently contain one, or more, of the processors listed in Table B-2, then a server upgrade is being performed, and system firmware and OS updates may be necessary. After any necessary system firmware and OS updates are performed, follow the processor removal and replacement procedures (see “Removing and Replacing a Processor” (page 175)).

## Firmware

Before upgrading the processor, ensure the server is at the required system firmware level. Check the system firmware version by executing the `info fw` command at the EFI Shell prompt.



**NOTE:** HP recommends using the latest version of firmware.

System firmware updates are available on the HP website at:  
<http://www.hp.com/support/itaniumservers>.

## Operating Systems



**IMPORTANT:** Check the HP IT Resource Center (ITRC) website at <http://itrc.hp.com> for any required OS patches.

**HP-UX** HP-UX supports the processor upgrade at the following minimum release levels:

- HP-UX 11.23 0706
- HP-UX 11.31 0709

**OpenVMS** OpenVMS must be upgraded to OpenVMS V8.3-1H1 to support the processor upgrade.

**Windows** Windows supports the processor upgrade.

**Linux** Linux supports the processor upgrade. If you choose to move any I/O cards or storage during this upgrade, Linux must be reinstalled.

# C Utilities

This appendix describes the utilities that are part of the server. These include the EFI Boot Manager and EFI-POSSE.

This appendix addresses the following topics:

- “Extensible Firmware Interface Boot Manager” (page 212)
- “EFI Commands” (page 213)
- “EFI/POSSE Commands” (page 215)
- “Specifying SCSI Parameters” (page 233)
- “Using the Boot Option Maintenance Menu” (page 238)
- “Integrated Lights Out 2 Management Processor” (page 243)

## Extensible Firmware Interface Boot Manager

Extensible Firmware Interface (EFI) is an OS and platform-independent boot and pre-boot interface. EFI resides between the OS and platform firmware. This allows the OS to boot without having details about the underlying hardware and firmware. EFI supports boot devices; uses a flat memory model; and hides platform and firmware details from the OS.



**NOTE:** EFI and Pre-OS System Environment (POSSE) are similar. EFI is an Intel specification, whereas POSSE is the HP implementation that aids HP support.

EFI consolidates boot utilities similar to those found in PA-RISC based servers, such as the Boot Console Handler (BCH), and platform firmware into a single platform firmware. EFI enables the selection of any EFI OS loader from any boot medium that is supported by EFI boot services. An EFI OS loader supports multiple options on the user interface.

EFI supports booting from media that contain an EFI OS loader or an EFI-defined system partition. An EFI-defined system partition is required by EFI to boot from a block device.

**Figure C-1 EFI Boot Sequence**

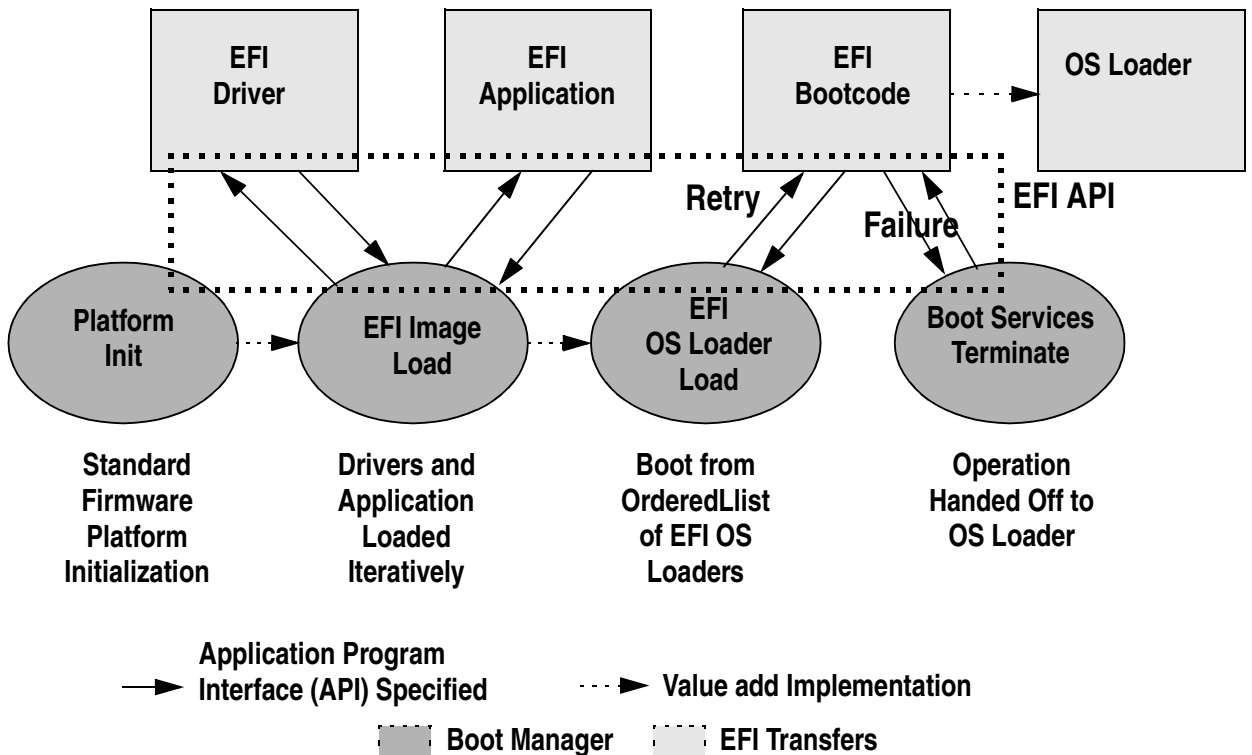

The EFI Boot Manager loads EFI applications (including operating system OS first stage loader) and EFI drivers from an EFI-defined file system or image loading service. Non-volatile RAM (NVRAM) variables point to the file to be loaded. These variables contain application-specific data that is passed directly to the EFI application. EFI variables provides system firmware with a boot menu that points to all the operating systems, even multiple versions of the same operating systems.

The EFI Boot Manager enables you to control the server booting environment. Depending on boot option configuration after the server is powered up, the Boot Manager presents you with different ways to bring up the system. For example, you can boot to the EFI Shell, to an operating system located on the network or residing on media in the server, or the **EFI Boot Maintenance** menu.

The following options are available in the **EFI Boot Manager** menu

- **Boot from File:** Allows you to launch a specific application without adding it as a boot option. When you select this option, a menu displays devices to choose your boot file from. Selecting a disk device then displays subdirectories and executable applications on that device. Search the subdirectories to find the correct file to boot from. If you choose a LAN device to boot from, you can boot the file from a remote server. The remote server must be set up ahead of time to recognize bootp requests from your server.

You can also launch a specific application without adding it as a boot option. In this case, the EFI Boot Manager searches the root directories and the \EFI\TOOLS directories of all of the EFI system partitions present in the system for the specified EFI application.

- **Add Boot Entry:** Adds a boot entry to the EFI Boot Manager. This works similarly to Boot from File, but adds the file to the boot menu as a new entry instead of just booting the file once. You must specify a name for the boot entry to be added, and you can add ASCII or UNICODE arguments to the application being launched.
- **Remove Boot Entry:** Deletes a specific boot option.
- **Change Boot Order:** Controls the relative order in which the EFI Boot Manager attempts to execute boot options. For help on the control key sequences you need for this option, see the help menu.
- **Manage BootNext Setting:** Selects a boot option to use only once (the next boot operation).
- **Set Automatic Boot Timeout:** Defines the value in seconds before the system automatically boots without user intervention. Set this value to zero to disable the timeout feature.
- **Exit:** Returns control to the **EFI Boot Manager** menu. This displays the active boot devices, including a possible integrated shell (if the implementation is so constructed).

For more information, see “Using the Boot Option Maintenance Menu” (page 238).

## EFI Commands

Table C-1 lists EFI commands for HP Integrity servers. The equivalent BCH commands found in PA-RISC based servers are also listed.

**Table C-1 EFI Commands**

EFI Shell Command	BCH Command Equivalent (PA-RISC)	BCH Command Parameters (PA-RISC)	Definition
These commands are found in all other menus			
info boot	Boot	[PRI HAA ALT <path>]	Boot from specified path
help <command>	HElp	[<menu> <command>]	Display help for specified command or menu
reset	RESET		Reset the server (to allow reconfiguration of complex
exit (at EFI Shell)	MAin		Return to the main menu
MAin			

**Table C-1 EFI Commands** (continued)

EFI Shell Command	BCH Command Equivalent (PA-RISC)	BCH Command Parameters (PA-RISC)	Definition
EFI Boot Manager "change boot order"	PAth	[PRI HAA ALT CON KEY <path>]	Display or modify a path
bcfg	SEArch	[ALL]	Search for boot devices
bcfg	SEArch	[DIsplay IPL] [<path>]	Search for boot devices
many commands offer a [-b] parameter to cause 25 line breaks	ScRoll	[ON OFF]	Display or change scrolling capability
COnfiguration			
autoboot	AUto	[Bboot SEarch StArt] [ON OFF]	Display or set the auto start flag
info boot	BootID	[<processor #>[<bootid #>]]	Display or set processor boot identifier
EFI Boot Manager	Boot info		Display boot-related information
autoboot	BootTimer	[0-200]	Seconds allowed for boot attempt
cpuconfig	CPUCONFIG	[<cpu>][ON OFF]	Configure or deconfigure processor
ioconfig	IOCONFIG	IOCONFIG [fast_init   mps_optimize   wol [on   off]]	Deconfigure or reconfigure I/O components or settings
boottest	FastBoot	[ON OFF] or [test] [RUN SKIP]	Display or set boot tests execution
date	Time	[cn:yr:mo:dy:hr:mn:ss]	Read or set the date
time	Time	[cn:yr:mo:dy:hr:mn:ss]	Read or set the real time clock
INformation			
info all	ALL		Display all server information
info boot	BootINfo		Display boot-related information
info cpu	CAche		Display cache information
info chiprev	ChipRevisions		Display revision number of major VLSI
MP command <df>	FRU		Display FRU information
info fw	FwrVersion		Display firmware version for PDC, ICM, and complex
info io	IO		Display firmware version for PDC, ICM, and complex
lanaddress	LanAddress		Display core LAN station address
info mem	Memory		Display memory information
info cpu	PRocessor		Display processor information
SERvice			

**Table C-1 EFI Commands** (continued)

EFI Shell Command	BCH Command Equivalent (PA-RISC)	BCH Command Parameters (PA-RISC)	Definition
errdump clear	CLEARPIM		Clear (zero) the contents of PIM
mm	MemRead	<addr> [<len>] [<type>]	Read memory locations scope of page deallocation
pdt	page deallocation table (pdt)		Display or clear the page deallocation table
errdump mca errdump cmc errdump init	processor internal memory (PIM)	[<proc>] [HPMC LPMC TOC ASIC]	Display PIM information

## EFI/POSSE Commands

This section provides information on the EFI/POSSE commands developed for the server.

EFI and Pre-OS System Environment (POSSE) are similar. EFI is an Intel specification, whereas POSSE is the HP implementation that aids HP support.



**NOTE:** Your output might not exactly match the output shown in this section due to the type of server you purchased.

## help

Provides information on the EFI Shell commands. It also has an additional feature to aid those familiar with the BCH menus of PA-RISC servers to adjust to their equivalent functions in EFI.

## Syntax

```
help [-b] <category>
help [-b] <cmd>
help [-b] bch <bchmenu> <bchcmd>
```

## Parameters

-b	Enable page breaking
category	Category of commands to view help on commands
cmd	Shell command name on which to provide verbose information
bch	Display the list of BCH commands and their corresponding EFI
bchmenu	BCH menu name taken from the top level of the BCH menu
bchcmd	BCH command on which to display information

## Operation

If help is initiated with no parameters, it displays a list of EFI Shell command categories. To list all of the commands within a category, enter **help <category>**. If help is issued with the **-b** option, any output longer than one page pauses after each page displays. If a shell command name is used as a parameter, verbose help displays for that command.

If you issue the help command with the **bch** option, it displays a list of BCH commands and their corresponding EFI/POSSE commands. It instructs you to repeat the command line followed by a menu name for more information on that menu. If you issue help within the **bch** option and a menu name, it displays a list of commands that appear under that BCH menu. You can then issue help followed by **bch**, the menu name, and a BCH command name to display information about that command. This points you to the EFI command that has taken the place of that BCH functionality, or informs the user that the functionality no longer exists. Alternately, enter help followed by bch and a BCH command name to go straight to that command.

The following examples show the available options and output:

## Example C-1 help command

---

```
Shell> help
List of classes of commands:

boot          -- Booting options and disk-related commands
configuration -- Changing and retrieving system information
devices       -- Getting device, driver and handle information
memory        -- Memory related commands
shell         -- Basic shell navigation and customization
scripts       -- EFI shell-script commands
Type "help" followed by a class name for a list of commands in that class
Type "help" followed by command name for full documentation
```

---

## Example C-2 help bch command

---

```
CONfiguration      help bch co
INformation        help bch in
PATH               help bch pa
ScRool             help bch sr
SEARch             help bch sea
SERvice            help bch ser
BOot               help bch bo
HELp               help bch he
RESET              help bch reset
MAIN               help bch ma
```

For more help on one of the commands above, at the prompt type:  
help bch <bchcmd>

---

## Example C-3 help configuration command

---

```
Shell> help configuration
Configuration commands:

cpuconfig -- Deconfigure or reconfigure cpus
date      -- Display or set date
err       -- Display or set error level
esiproc   -- Make an ESI call
errdump   -- View/Clear logs
info      -- Display hardware information
monarch   -- View or set the monarch processor
palproc   -- Make a PAL call
salproc   -- Make a SAL call
time      -- Display or set time
ver       -- Displays version info
```

Type "help" followed by command name for full documentation on that command.  
Type "help -a" to display a list of all commands.

---



## Example C-4 help cpuconfig command

---

```
Shell> help cpuconfig
Deconfigure or reconfigure cpus
```

```
CPUCONFIG [module] | [threads] [on|off]
```

```
module : Specifies which cpu module to configure
threads : Use to display info or configure threads
on|off : Specifies to configure or deconfigure a cpu module or threads
```

Note:

1. Cpu status will not change until next boot.
2. Specifying a cpu number without a state will display configuration status.

Examples:

```
* To deconfigure CPU 0
fs0:\> cpuconfig 0 off
Cpu will be deconfigured on the next boot.
```

```
* To display configuration status of cpus
fs0:\> cpuconfig
```

### PROCESSOR MODULE INFORMATION

CPU Module	# of Logical CPUs	Speed	L3 Cache Size	L4 Cache Size	Family/ Model (hex.)	Rev	Processor State
0	2	1.1 GHz	4MB	32MB	1F/01	B1	Active
1	2	1.1 GHz	4MB	32MB	1F/01	B1	Active

```
* To display cpu thread status
fs0:\> cpuconfig threads
```

```
cpuconfig: Threads are turned off.
```

```
* To enable cpu threads
fs0:\> cpuconfig threads on
```

```
cpuconfig: Threads will be on after a reset
```

```
* To disable cpu threads
fs0:\> cpuconfig threads off
```

```
cpuconfig: Threads will be off after a reset
```

---

## Example C-5 help ioconfig command

---

```
Shell> help ioconfig
Deconfigure or reconfigure IO components or settings

IOCONFIG [fast_init|wol [on|off]]

fast_init  Specifies device connection policy setting
wol        Specifies System Wake-On-LAN setting
on|off     Specifies to configure or deconfigure a feature or component

Note:
  1. If fast_init is enabled, firmware will connect only the minimum set of
     devices during boot. This feature might cause boot failure; disable this
     feature if failure occurs.

  2. Any pending Wake-On-LAN request will not be cleared until reboot if
     the setting is changed to disabled.

     System will clear pending Wake-On-LAN requests each time the system
     reboots if the setting is disabled.

Examples:
  * To display the current settings
    fs0:\> ioconfig
    Fast initialization: Enabled
    System Wake-On-LAN: Disabled

  * To display the current device connection policy setting
    fs0:\> ioconfig fast_init
    Fast initialization: Enabled

  * To disable fast initialization
    fs0:\> ioconfig fast_init off
    Fast initialization: Disabled

  * To enable the System Wake-On-LAN setting
    fs0:\> ioconfig wol on
    System Wake-On-LAN: Enabled
```

---

## baud

Sets the baud rate and communication settings for a universal asynchronous receiver-transmitter (UART).

## Syntax

```
baud <index> <baudrate>
```

## Parameters

<index> 0 through the total number of UARTS minus one  
<baudrate> baud rate.

## Operation

Use this command to change the speed for a UART in the system. This command works for all UARTs visible to EFI/POSSE. If the UART is part of processor dependent hardware (PDH) space and is initialized by the core firmware, this command communicates the settings to core firmware so the UART can be initialized with the new settings on the next boot. System default is 9600 baud.

Table C-2 lists other communication parameters.

**Table C-2 Communications Parameters**

Parameter	Value
RECEIVE_FIFO_DEPTH	1
TIMEOUT	1000000
PARITY	No parity
DATA_BITS	8
STOP_BITS	1
CONTROL_MASK	0

## boottest

Interacts with the speedy boot variable allowing it to be set appropriately.

### Syntax

```
boottest                Displays status of all speedy boot bits
boottest on             Run all tests (for a normal boot time)
boottest off           Skip all tests (for a faster boot time)
boottest [test]        Displays status of specific Speedy Boot bit
boottest [test] [on|off] Sets or clears a specific Speedy Boot bit
```

### Parameters

```
[test]  Each test can be set or cleared:
booting_valid  Enable/disable system firmware response to BOOTING
               bit. If OS Speedy Boot aware set to on.
early_cpu     Enable/disable early CPU selftests.
late_cpu      Enable/disable late CPU selftests.
platform      Enable/disable system board hardware tests.
chipset       Enable/disable CEC tests.
io_hw         Enable/disable EFI driver Core I/O tests.
mem_init      Enable/disable memory initialization.
mem_test      Enable/disable full destructive memory tests.
```

## Example C-6 boottest command

---

```
Shell> boottest
BOOTTEST Settings Default Variable
Selftest          Setting
-----
booting_valid     On (OS speedy boot aware)
early_cpu         Run this test
late_cpu          Run this test
platform          Run this test
chipset           Run this test
io_hw             Run this test
mem_init          Run this test
mem_test          Run this test
```

---

## Example C-7 boottest early\_cpu off command

---

```
Shell> boottest early_cpu off
BOOTTEST Settings Default Variable
Selftest          Setting
-----
booting_valid     On (OS speedy boot aware)
early_cpu         Skip this test
late_cpu          Run this test
platform          Run this test
chipset           Run this test
io_hw             Run this test
mem_init          Run this test
mem_test          Run this test
```

---

## cpuconfig

Displays the configured or deconfigured state of processors in the system and enables you to configure or reconfigure processors.

### Syntax

```
cpuconfig <cpu> <on|off>
```

### Parameters

<cpu>	specify a processor
<on off>	state to set the processor to

### Operation

Issuing `cpuconfig` with no parameters displays the config/deconfig status of all processors. To reconfigure CPUs, specify a CPU number and a state `on` or `off`. If a valid state is entered and is different from the current state of a CPU, its status changes on the next boot.



---

**NOTE:** The last remaining configured CPU in a server cannot be deconfigured.

---

### Example C-8 `cpuconfig` command

---

```
Shell> cpuconfig  
PROCESSOR INFORMATION
```

CPU	Speed	Proc Rev	Model	Family	Arch Rev	Processor State
0	1.6Ghz	B1	0	31	0	Sched Deconf
1	1.6Ghz	B1	0	31	0	Active

---

## ioconfig

Use this command to deconfigure or reconfigure I/O components or settings.

### Syntax

```
ioconfig <fast_init | mps_optimize | wol> <on | off>
```

### Parameters

```
<fast_init>    specify device connection policy setting  
<mps_optimize> specify PCIe MPS optimization setting  
<wol>         specify system wake-on-lan setting  
<on|off>      specify to configure or deconfigure a feature or component
```

### Operation

The `ioconfig` file is used to retain information on the server I/O configuration across reboots. The `ioconfig` file is created by `insf` at install time; and is modified by `insf`, `rmsf`, and `ioscan` when devices are added or removed. The only purpose of the `ioconfig` file to maintain configuration information when the system is not running.

## Example C-9 ioconfig command

---

```
Shell> ioconfig
Deconfigure or reconfigure IO components or settings

IOCONFIG [fast_init|wol [on|off]]

fast_init Specifies device connection policy setting
mps_optimie Specifies PCIe optimization setting
wol Specifies System Wake-On-LAN setting
on|off Specifies to configure or deconfigure a feature or component

Note:
1. If fast_init is enabled, firmware will connect only the minimum set of
   devices during boot. This feature might cause boot failure; disable this
   feature if failure occurs.

2. A reboot is required for PCIe MPS sptimiation changes to take effect

3. Any pending Wake-On-LAN request will not be cleared until reboot if
   the setting is changed to disabled.

   System will clear pending Wake-On-LAN requests each time the system
   reboots if the setting is disabled.
```

### Examples:

- \* To display the current settings

```
fs0:\> ioconfig
Fast initialization: Enabled
MPS optimization: Disabled
System Wake-On-LAN: Disabled
```
  - \* To display the current device connection policy setting

```
fs0:\> ioconfig fast_init
Fast initialization: Enabled
```
  - \* To disable fast initialization

```
fs0:\> ioconfig fast_init off
Fast initialization: Disabled
```
  - \* To enable the System Wake-On-LAN setting

```
fs0:\> ioconfig wol on
System Wake-On-LAN: Enabled
```
- 

## conconfig

Configures the primary console and turns on other consoles for mirroring from the firmware.

### Syntax

```
conconfig [index] [on|off|primary]
```

### Parameters

Index	Specifies index of console to set as primary
on	Enables the specified console as a secondary console
off	Puts console into "Not Configured" (NC) state
primary	Sets the specified console as primary

### Notes

- Primary console setting takes effect after reboot.
- **P** in the status column indicates that the console is the primary.
- **S** in the status column indicates that the console is the secondary.
- **NC** in the status column indicates that the console is not configured.
- If a disabled console is set to primary, it is enabled.

### Example C-10 conconfig command

To display current primary operating system console:

```
Shell> conconfig
CONSOLE CONFIGURATION
Index Status Type      Device Path
-----
1      NC   Serial  Acpi (PNP0501,0)
2      S   Serial  Acpi (HWP0002,0) /Pci (1|1)
3      P   VGA     Acpi (HWP0002,0) /Pci (4|0)
```

### Example C-11 conconfig 2 primary command

To change primary operating system console:

```
Shell> conconfig 2 primary
CONSOLE CONFIGURATION
Index Status Type      Device Path
-----
1      NC   Serial  Acpi (PNP0501,0)
2      P   Serial  Acpi (HWP0002,0) /Pci (1|1)
3      S   VGA     Acpi (HWP0002,0) /Pci (4|0)
```

### Example C-12 conconfig 3 off command

To disable a console:

```
Shell> conconfig 3 off
CONSOLE CONFIGURATION
Index Status Type      Device Path
-----
1      NC   Serial  Acpi (PNP0501,0)
2      P   Serial  Acpi (HWP0002,0) /Pci (1|1)
3      NC   VGA     Acpi (HWP0002,0) /Pci (4|0)
```

### Example C-13 conconfig 3 on command

To enable a console:

```
Shell> conconfig 3 on
CONSOLE CONFIGURATION
Index Status Type      Device Path
-----
1      NC   Serial  Acpi (PNP0501,0)
2      P   Serial  Acpi (HWP0002,0) /Pci (1|1)
3      S   VGA     Acpi (HWP0002,0) /Pci (4|0)
```

## default

Enables you to restore non-volatile memory (NVM) to default values and clear NVM storage values.

## Syntax

```
default      [efi|sal]
default      clear [bmc|efi|sal]
```

## Parameters

```
clear        clears NVM storage values
```

## Operation

Sets NVM and stable store values to predefined default values. Normally only a subset of values are available for default. To reset the system, execute the `default clear` command.

## errdump

Displays the contents of processor internal memory logged on the first machine check abort (MCA) for all processors present in the system.

## Syntax

```
errdump [mca | cpe | cmc | init | la | clear]
```

## Parameters

mca	dumps the Machine Check Abort error log
cpe	dumps the Corrected Platform Error log
cmc	dumps the Corrected Machine Check log
init	dumps the Initialization log
la	dumps the Logic Analyzer log
clear	erases all of the logs (mca, cpe, cmc, init, la)

## Operation

Enter `errdump` with no parameters to display usage. Otherwise, the specified error log displays. Add `-n` to the `clear` parameter to disable the confirmation prompt. Access the `errdump` command from the System Configuration menu.

## info

Displays most server information.

## Syntax

```
info [ -b ] [target]
```

## Parameters

target:	valid targets are:
all	display everything
cpu	display information on cpus
cache	display information on cache
mem	display information on memory
io	display information on io
boot	display boot-related information
chiprev	display information on chip revisions
fw	display firmware version information
sys	display system information
warning	display warning and stop boot information



## Example C-14 info all command

```
Shell> info all
```

### SYSTEM INFORMATION

```
Date/Time: Jan 1, 1998 00:09:35 (19:98:01:01:00:09:35)
Manufacturer: hp
Product Name: server rx2660
Product Number: AB419-2101A
Serial Number: TWT46241EF
UUID: 30303030-3030-3030-3030-303030303030
System Bus Frequency: 200 MHz
```

### PROCESSOR MODULE INFORMATION

CPU Module	# of Logical CPUs	Speed	L3 Cache Size	L4 Cache Size	Family/Model (hex.)	Rev	Processor State
0	2	1.4 GHz	6 MB	None	20/00	C0	Active

CPU threads are turned off.

### MEMORY INFORMATION

	DIMM A		DIMM B	
	DIMM	Current	DIMM	Current
0	512MB	Active	512MB	Active
1	512MB	Active	512MB	Active
2	----		----	
3	----		----	

```
Active Memory : 2048 MB
Installed Memory : 2048 MB
```

### I/O INFORMATION

#### BOOTABLE DEVICES

Order	Media Type	Path
1	HARDDRIVE	Acpi (HWP0002, PNP0A03, 200) / Pci (1   0) / Sas (Addr500000E0119F9C12, Lun0) / HD (Part1, Sig4258E658-7952-11DB-8002-D6217B60E588)
2	HARDDRIVE	Acpi (HWP0002, PNP0A03, 200) / Pci (1   0) / Sas (Addr500000E0119F9C12, Lun0) / HD (Part3, Sig4258E6B2-7952-11DB-8004-D6217B60E588)

Seg #	Bus #	Dev #	Fnc #	Vendor ID	Device ID	Slot #	Path
00	00	01	00	0x103C	0x1303	XX	Acpi (HWP0002, PNP0A03, 0) / Pci (1   0)
00	00	01	01	0x103C	0x1302	XX	Acpi (HWP0002, PNP0A03, 0) / Pci (1   1)
00	00	01	02	0x103C	0x1048	XX	Acpi (HWP0002, PNP0A03, 0) / Pci (1   2)
00	00	02	00	0x1033	0x0035	XX	Acpi (HWP0002, PNP0A03, 0) / Pci (2   0)
00	00	02	01	0x1033	0x0035	XX	Acpi (HWP0002, PNP0A03, 0) / Pci (2   1)
00	00	02	02	0x1033	0x00E0	XX	Acpi (HWP0002, PNP0A03, 0) / Pci (2   2)
00	00	03	00	0x1002	0x515E	XX	Acpi (HWP0002, PNP0A03, 0) / Pci (3   0)
00	01	01	00	0x1000	0x0054	XX	Acpi (HWP0002, PNP0A03, 200) / Pci (1   0)
00	01	02	00	0x14E4	0x1648	XX	Acpi (HWP0002, PNP0A03, 200) / Pci (2   0)
00	01	02	01	0x14E4	0x1648	XX	Acpi (HWP0002, PNP0A03, 200) / Pci (2   1)

```
Fast initialization: Enabled
System Wake-On-LAN: Enabled
```

### BOOT INFORMATION

Monarch CPU:

Current	Preferred
Monarch	Monarch

CPU Module/ Logical	CPU Module/ Logical	Warnings
-----	-----	-----
0/0	0/0	

AutoBoot: OFF - Timeout is disabled

Boottest:

BOOTTEST Settings Default Variable

OS is not speedy boot aware.

Selftest	Setting
-----	-----
early_cpu	Run this test
late_cpu	Run this test
platform	Run this test
chipset	Run this test
io_hw	Run this test
mem_init	Run this test
mem_test	Run this test

LAN Address Information:

LAN Address	Path
-----	-----
*Mac(001635C6214E)	Acpi(HWP0002,PNP0A03,200)/Pci(2 0)/Mac(001635C6214E)
Mac(001635C6214D)	Acpi(HWP0002,PNP0A03,200)/Pci(2 1)/Mac(001635C6214D)

#### FIRMWARE INFORMATION

\*System Firmware A Revision: 62.01 [4623]  
 PAL\_A: 7.31/7.46  
 PAL\_B: 7.46  
 EFI Spec: 1.10  
 EFI Intel Drop: 14.62  
 EFI Build: 5.56  
 SAL Spec: 3.20  
 SAL\_A: 2.00  
 SAL\_B: 62.01  
 POSSE: 0.20  
 ACPI: 7.00  
 SMBIOS: 2.3.2a

System Firmware B Revision: 62.05 [4628]  
 BMC Revision: 75.07  
 IPMI: 1.00

Management Processor Revision: F.01.40

Updatable EFI Drivers:

Floating-Point Software Assistance Handler:	00000118
Broadcom Gigabit Ethernet Driver:	0007000A
SCSI Bus Driver:	00000021
SCSI Tape Driver:	00000020
Usb Ohci Driver:	00000034
USB Bus Driver:	00000014
USB Bot Mass Storage Driver:	00000014
Generic USB Mass Storage Driver:	00000015

\* Indicates active system firmware image

#### WARNING AND STOP BOOT INFORMATION

Warning[55]: Invalid or inaccessible system ID(s)

#### CHIP REVISION INFORMATION

Chip Type	Logical ID	Device ID	Chip Revision
-----	-----	-----	-----
Memory Controller	0	4032	0020
Root Bridge	0	4030	0020

```

Host Bridge      0000      122e      0032
Host Bridge      0002      122e      0032
Host Bridge      0003      12ee      0011
Host Bridge      0006      12ee      0011
Host Bridge      0007      12ee      0011
Other Bridge      0         0         0030
  Other Bridge    0         0         000d
  Baseboard MC    0         0         7507

```

SYSTEM SECURITY CONFIGURATION

```

Trusted Boot:      No Supported
TPM:               Not Present

```

Shell>

**Example C-15** info cpu command

This example has processor hyperthreading turned on:

Shell> info cpu

PROCESSOR MODULE INFORMATION

CPU Module	# of Logical CPUs	Speed	L3 Cache Size	L4 Cache Size	Family/Model (hex.)	Rev	Processor State
0	4	1.4 GHz	6 MB	None	20/00	B0	Active
1	4	1.4 GHz	6 MB	None	20/00	B0	Active

CPU threads are turned on.

This example has processor hyperthreading turned off:

Shell> info cpu

PROCESSOR MODULE INFORMATION

CPU Module	# of Logical CPUs	Speed	L3 Cache Size	L4 Cache Size	Family/Model (hex.)	Rev	Processor State
0	2	1.4 GHz	6 MB	None	20/00	B0	Active
1	2	1.4 GHz	6 MB	None	20/00	B0	Active

CPU threads are turned off.

## Example C-16 info mem command

---

```
Shell> info mem
```

### MEMORY INFORMATION

```
      ---- DIMM A -----      ---- DIMM B -----
      DIMM   Current         DIMM   Current
----
0    256MB   Active         256MB   Active
1    256MB   Active         256MB   Active
2    ----
3    ----
4    ----
5    ----

Active Memory      : 1024 MB
Installed Memory   : 1024 MB
```

---

## Example C-17 info io command

---

```
Shell> info io
```

### I/O INFORMATION

#### BOOTABLE DEVICES

```
Order  Media Type  Path
-----
1      CDROM       Acpi(HWP0002,0)/Pci(2|0)/Ata(Primary,Master)/CDROM(Entry0)
```

```
Seg  Bus  Dev  Fnc  Vendor  Device  Slot  Path
#    #   #   #   ID      ID      #   -----
---  ---  ---  ---  ---     ---     ---  -----
00   00   01   00  0x1033  0x0035  XX  Acpi(HWP0002,0)/Pci(1|0)
00   00   01   01  0x1033  0x0035  XX  Acpi(HWP0002,0)/Pci(1|1)
00   00   01   02  0x1033  0x00E0  XX  Acpi(HWP0002,0)/Pci(1|2)
00   00   02   00  0x1095  0x0649  XX  Acpi(HWP0002,0)/Pci(2|0)
00   20   01   00  0x1000  0x0030  XX  Acpi(HWP0002,100)/Pci(1|0)
00   20   01   01  0x1000  0x0030  XX  Acpi(HWP0002,100)/Pci(1|1)
00   20   02   00  0x8086  0x1079  XX  Acpi(HWP0002,100)/Pci(2|0)
00   20   02   01  0x8086  0x1079  XX  Acpi(HWP0002,100)/Pci(2|1)
00   40   01   00  0x1000  0x0021  03  Acpi(HWP0002,200)/Pci(1|0)
00   60   01   00  0x1077  0x2312  02  Acpi(HWP0002,300)/Pci(1|0)
00   60   01   01  0x1077  0x2312  02  Acpi(HWP0002,300)/Pci(1|1)
00   80   01   00  0x1000  0x000F  01  Acpi(HWP0002,400)/Pci(1|0)
00   80   01   01  0x1000  0x000F  01  Acpi(HWP0002,400)/Pci(1|1)
00   C0   01   00  0x1000  0x0021  04  Acpi(HWP0002,600)/Pci(1|0)
00   E0   01   00  0x103C  0x1290  XX  Acpi(HWP0002,700)/Pci(1|0)
00   E0   01   01  0x103C  0x1048  XX  Acpi(HWP0002,700)/Pci(1|1)
00   E0   02   00  0x1002  0x5159  XX  Acpi(HWP0002,700)/Pci(2|0)

System Wake-On-LAN: Enabled
```

---

## Example C-18 info boot command

---

```
Shell> info boot
```

```
BOOT INFORMATION
```

```
Monarch CPU:
```

Current	Preferred	
Monarch	Monarch	
CPU	CPU	
Module/	Module/	
Logical	Logical	Warnings
-----	-----	-----
0/0	0/0	

```
AutoBoot: ON - Timeout is : 10 sec
```

```
Boottest:
```

```
BOOTTEST Settings Default Variable
```

```
OS is not speedy boot aware.
```

Selftest	Setting
-----	-----
early_cpu	Run this test
late_cpu	Run this test
platform	Run this test
chipset	Run this test
io_hw	Run this test
mem_init	Run this test
mem_test	Run this test

```
LAN Address Information:
```

LAN Address	Path
-----	-----
*Mac (000E7F7E07FA)	Acpi (HWP0002,100)/Pci (2 0)/Mac (000E7F7E07FA)
Mac (000E7F7E07FB)	Acpi (HWP0002,100)/Pci (2 1)/Mac (000E7F7E07FB)

---

## lanaddress

Displays the core I/O MAC address.

Syntax:

```
lanaddress
```

Parameters

```
none
```

## Example C-19 lanaddress command

---

```
LAN Address Information:
```

LAN Address	Path
-----	-----
Mac (00306E4C4F1A)	Acpi (HWP0002,0)/Pci (3 0)/Mac (00306E4C4F1A)
*Mac (00306E4C0FF2)	Acpi (HWP0002,100)/Pci (2 0)/Mac (00306E4C0FF2)

---

## monarch

Displays or modifies the ID of the bootstrap processor. The preferred monarch number is stored in NVM.

## Syntax

```
monarch <cpu>
```

## Parameters

```
<cpu>          specifies a cpu
```

## Operation

If specified with no parameters, `monarch` displays the Monarch processor for the server. Specifying a processor number alters the preferred Monarch processor. None of these changes takes affect until after a reboot.

### Example C-20 monarch command

---

```
Shell> monarch
Current      Preferred
Monarch      Monarch      Possible Warnings
-----
           0           0
           0           0
```

To view monarch: fs0 :\ monarch

```

                | Processor
-----+-----
current status  |      0
next boot status |      0
```

To set the monarch processor to 1: fs0 :\ monarch 1

```

                | Processor
-----+-----
current status  |      0
next boot status |      1
```

---

## pdt

Displays or clears the contents of the Page Deallocation Table (PDT).

## Syntax

```
pdt (clear)
```

## Parameters

```
<clear>       clears the pdt
```

## Operation

With no options specified, the command displays the PDT information for the server. The PDT is cleared and a reboot is required for memory reallocation and safe booting.

## Example C-21 pdt command

---

```
Shell> pdt
PDT Information for PD

Last Clear time for PD: PDT has not been cleared
Number of total entries in PD PDT:                100
Number of used entries in PD PDT:                  0
Number of free entries in PD PDT:                   50
Number of permanent correctable (SBE) entries in PD PDT: 0
Number of permanent uncorrectable (MBE) entries in PD PDT: 0
Address of first uncorrectable error in PD: 0x0000000000000000
```

---

## Example C-22 pdt clear command

---

```
Shell> pdt clear
Are you sure you want to clear the PDT? [y/N] y
Shell>
```

```
Shell> pdt
PDT Information

                Last Clear time: 10/21/01  5:00p
Number of total entries in PDT:                50
Number of used entries in PDT:                  0
Number of free entries in PDT:                   50
Number of single-bit entries in PDT:             0
Number of multi-bit entries in PDT:              0
Address of first multi-bit error: 0x0000000000000000
```

---

## sysmode

Displays or modifies the system mode.

### Syntax

```
sysmode <normal | admin| service>
```

### Parameters

```
<normal>      sets system mode to normal
<admin>       sets system mode to admin
<service>    sets system mode to service
```

### Operation

If specified alone, `sysmode` displays the system mode. If a mode is specified as a parameter, the system mode changes immediately. The system mode is retained on successive boots.

## Example C-23 sysmode command

```
Shell> sysmode
System Mode: NORMAL

Shell> sysmode admin
You are now in admin mode.

Shell> sysmode service
You are now in service mode.

Shell> sysmode normal
You are now in normal mode
```

## Option ROM Configuration for Arrays Utility

The Option ROM Configuration for Arrays (ORCA) utility is a ROM-based utility for manually configuring an array on a Smart Array controller.



**NOTE:** Due to the type of server you purchased, your output may not exactly match the output shown in this section.

To use **ORCA**, follow these steps:

1. Power on the server. POST runs, and any array controllers that are in the server are initialized one at a time. During each controller initialization process, POST halts for several seconds while an **ORCA** prompt message appears.
2. At the **ORCA** prompt:
  - If you are connected using a headless console, press the **Esc+8** combination.
  - Otherwise, press **F8**. The **ORCA Main Menu** appears, allowing you to create, view, or delete a logical drive.

Figure C-2 ORCA Main Menu

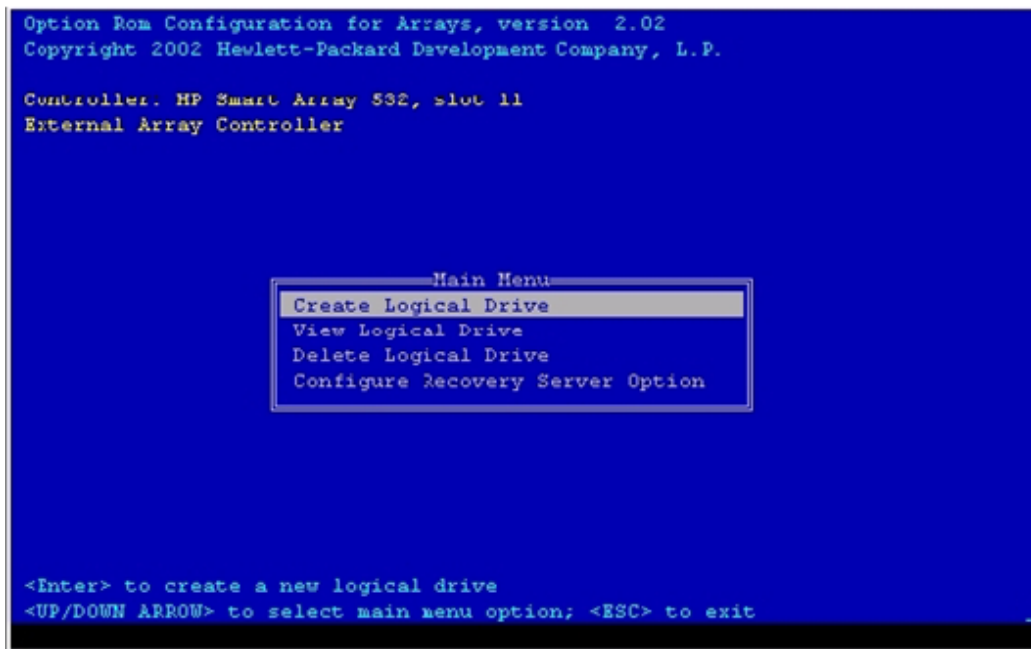

## Creating a Logical Drive Using ORCA

To create a logical drive using **ORCA**, follow these steps:

1. Select **Create Logical Drive**. The screen displays a list of all available (unconfigured) physical drives and the valid RAID options for the system.



2. Use the **Arrow** keys, **Spacebar**, and **Tab** to navigate around the screen and set up the logical drive, including an online spare drive if one is required.



---

**NOTE:** You cannot use **ORCA** to configure one spare drive to be shared among several arrays.

---

3. Press **Enter** to accept the settings.
4. Press **F8** to confirm the settings and save the new configuration. After several seconds, the Configuration Saved screen appears.
5. Press **Enter** to continue. You can now create another logical drive by repeating the previous steps.



---

**NOTE:** Newly created logical drives are invisible to the operating system. To make the new logical drives available for data storage, format them using the instructions given in the operating system documentation.

---

## Specifying SCSI Parameters

The following SCSI parameters may be configured for the SCSI board:

- SCSI ID (SCSI initiator ID)
- Maximum data transfer rate (SCSI rate)
- Bus width
- Whether the HBA is bootable (driver support)
- Avoid bus resets (secondary cluster server)



---

**NOTE:** Your output might differ from the output in the following examples depending on your server and its configuration.

---

## Using the SCSI Setup Utility

To use the SCSI Setup Utility to specify SCSI parameters, follow these steps:

- At the EFI Shell prompt, enter the `info io` command to map the parameters for all PCI cards installed in the server:

A list of all the devices that are installed in the server and managed by EFI drivers displays. For example:

```
I/O INFORMATION
```

```
BOOTABLE DEVICES
```

Order	Media	Type	Path				
1	CDROM		Acpi (HWP0002, 0) /Pci (2   0) /Ata (Primary, Master) /CDROM (Entry0)				

Seg #	Bus #	Dev #	Fnc #	Vendor ID	Device ID	Slot #	Path
00	00	01	00	0x1033	0x0035	XX	Acpi (HWP0002, 0) /Pci (1   0)
00	00	01	01	0x1033	0x0035	XX	Acpi (HWP0002, 0) /Pci (1   1)
00	00	01	02	0x1033	0x00E0	XX	Acpi (HWP0002, 0) /Pci (1   2)
00	00	02	00	0x1095	0x0649	XX	Acpi (HWP0002, 0) /Pci (2   0)
00	20	01	00	0x1000	0x0030	XX	Acpi (HWP0002, 100) /Pci (1   0)
00	20	01	01	0x1000	0x0030	XX	Acpi (HWP0002, 100) /Pci (1   1)
00	20	02	00	0x8086	0x1079	XX	Acpi (HWP0002, 100) /Pci (2   0)
00	20	02	01	0x8086	0x1079	XX	Acpi (HWP0002, 100) /Pci (2   1)
00	40	01	00	0x1000	0x0021	03	Acpi (HWP0002, 200) /Pci (1   0)
00	60	01	00	0x1077	0x2312	02	Acpi (HWP0002, 300) /Pci (1   0)
00	60	01	01	0x1077	0x2312	02	Acpi (HWP0002, 300) /Pci (1   1)
00	80	01	00	0x1000	0x000F	01	Acpi (HWP0002, 400) /Pci (1   0)
00	80	01	01	0x1000	0x000F	01	Acpi (HWP0002, 400) /Pci (1   1)
00	C0	01	00	0x1000	0x0021	04	Acpi (HWP0002, 600) /Pci (1   0)
00	E0	01	00	0x103C	0x1290	XX	Acpi (HWP0002, 700) /Pci (1   0)
00	E0	01	01	0x103C	0x1048	XX	Acpi (HWP0002, 700) /Pci (1   1)
00	E0	02	00	0x1002	0x5159	XX	Acpi (HWP0002, 700) /Pci (2   0)

```
System Wake-On-LAN: Enabled
```

In this example, a single SCSI interface is listed.

For each channel of the SCSI board, note certain information. For example, look at the information for the SCSI interface. For each channel of *this* SCSI interface, note the following information:

- **Bus #:** Identifies the bus the device is on. This is the same for both channels. In this example, the bus number is 20.
- **Dev #:** The ID the device is assigned on the bus. This is the same for both channels. In this example, the SCSI interface is device 01.
- **Fnc #:** Identifies the channel of the device (00 for channel A, 01 for channel B, and so on). In this example, because the SCSI interface has two channels, one channel is 00 and the other is 01.
- **Vendor ID:** Shows the device vendor ID. This is the same for both channels. For all SCSI interfaces, the ID is 0x1000.
- **Device ID:** Shows the device ID. This is the same for both channels. In this example, the SCSI interface the ID is 0x0030.
- **Slot #:** Identifies the physical card slot in the system where the SCSI interface is installed. This is the same for both channels. In this example, the SCSI interface is on the system board, therefore the slot number is xx.
- **Path:** Identifies the device path. In this example, the SCSI interface path is `Acpi (HWP0002, 200) /Pci (1 | 0)` for channel A and `Acpi (HWP0002, 200) /Pci (1 | 1)` for channel B.

Using the SCSI interface information from this example, the combined information that tells you this is a SCSI interface is as follows:

00	20	01	00	0x1000	0x0030	xx	Acpi (HWP0002, 200) /Pci (1   0)
00	20	01	01	0x1000	0x0030	xx	Acpi (HWP0002, 200) /Pci (1   1)

The vendor (0x1000) and device (0x0030) are the IDs for a SCSI interface. Of the devices with those IDs, this device has two channels (Fnc # of 00 immediately followed by Fnc # of 01).

Also, this SCSI interface has a non-numeric (XX) slot # indicating that it is on the system board.

2. From the EFI Shell prompt, enter the `devtree` command to obtain the controller handle for the SCSI interface. A tree of all EFI-capable devices installed in the system displays.

For example:

```
Shell> devtree
Device Tree
  Ctrl[04]
  Ctrl[06] VenHw(SysROM)
  Ctrl[0B] Acpi(HWP0002,0)
    Ctrl[15] Usb Open Host Controller
    Ctrl[16] Usb Open Host Controller
    Ctrl[17] Acpi(HWP0002,0)/Pci(1|2)
    Ctrl[18] PCI IDE/ATAPI Controller
    Ctrl[56] DV-28E-C
      Ctrl[91] FAT File System [FAT32] 118 MB
  Ctrl[0C] Acpi(HWP0002,100)
    Ctrl[1C] LSI Logic Ultra320 SCSI Controller
    Ctrl[1D] LSI Logic Ultra320 SCSI Controller
    Ctrl[1E] Acpi(HWP0002,100)/Pci(2|0)
      Ctrl[57] Acpi(HWP0002,100)/Pci(2|0)/Mac(000E7F7E07FA)
    Ctrl[1F] Acpi(HWP0002,100)/Pci(2|1)
      Ctrl[58] Acpi(HWP0002,100)/Pci(2|1)/Mac(000E7F7E07FB)
  Ctrl[0D] Acpi(HWP0002,200)
    Ctrl[20] Acpi(HWP0002,200)/Pci(1|0)
  Ctrl[0E] Acpi(HWP0002,300)
    Ctrl[22] HP 2 Gb Dual Port PCI/PCI-X Fibre Channel Adapter ( Port 1)
    Ctrl[23] HP 2 Gb Dual Port PCI/PCI-X Fibre Channel Adapter ( Port 2)
  Ctrl[0F] Acpi(HWP0002,400)
    Ctrl[24] Acpi(HWP0002,400)/Pci(1|0)
    Ctrl[25] Acpi(HWP0002,400)/Pci(1|1)
  Ctrl[10] Acpi(HWP0002,600)
    Ctrl[26] Acpi(HWP0002,600)/Pci(1|0)
  Ctrl[11] Acpi(HWP0002,700)
    Ctrl[27] Acpi(HWP0002,700)/Pci(1|0)
    Ctrl[28] Acpi(HWP0002,700)/Pci(1|1)
      Ctrl[43] 16550 Serial UART Driver
      Ctrl[44] VT-100+ Serial Console
        Ctrl[3E] Primary Console Input Device
        Ctrl[3F] Primary Console Output Device
        Ctrl[3D] Primary Standard Error Device
    Ctrl[29] Acpi(HWP0002,700)/Pci(2|0)
  Ctrl[40] Acpi(PNP0501,0)
    Ctrl[41] 16550 Serial UART Driver
      Ctrl[42] VT-100+ Serial Console
  Ctrl[54] VenHw(D65A6B8C-71E5-4DF0-A909-F0D2992B5AA9)
```

This information describes the SCSI interface because the path on the first line, `Acpi(HWP0002,100)`, is the path from the information displayed by the `info io` command. The next two lines describe the SCSI interface two channels, one line for each channel. The lines contain the SCSI interface description [LSI Logic Ultra160 SCSI Controller]. The value shown for `Ctrl`—17 and 18 at the beginning of each line is the controller handle for each channel. You need this value for the next step.



---

**NOTE:** The controller handle values change on every boot.

---

3. From the EFI Shell prompt, enter the `Shell> drvcfg` command to obtain the EFI driver handle for the SCSI interface. A list of all EFI-capable configurable components in the system is displayed.

For example:

```
Shell> drvcfg
Configurable Components
Drv[3D] Ctrl[15] Lang[eng]
Drv[3F] Ctrl[19] Lang[eng]
```

```
Drv[45] Ctrl[1C] Lang[eng]
Drv[45] Ctrl[1D] Lang[eng]
```

This listing shows which driver controls which device (controller). This information describes a SCSI interface because the values shown for `Ctrl`—17 and 18 are the controller handles for the SCSI interface two channels (from the information displayed by the `devtree` command).



**NOTE:** The EFI driver handle values change on every boot.

---



**TIP:** From the `drvcfg` command, record these two pieces of information for each channel of each SCSI interface for parameters to be changed:

- `Drv`(the EFI driver handle)
  - `Ctrl`(the controller handle)
- 

4. Using the driver handle [`Drv`] and the controller handle [`Ctrl`] from the `drvcfg` command, start the EFI SCSI Setup Utility for one channel of this SCSI interface.

At the EFI Shell prompt, enter:

```
Shell> drvcfg -s drv_handle cntrl_handle
```

where

- *drv\_handle* The handle of the driver that controls the channel with the SCSI ID you want to display or change
- *cntrl\_handle* The handle of the controller for the channel with the SCSI ID you want to display or change

For channel A of this SCSI interface, enter:

```
Shell> drvcfg -s 45 18
```

The EFI SCSI Setup Utility starts and its main menu appears, showing a list of all the EFI capable SCSI interfaces in the system.

5. Move the cursor to highlight the channel of the SCSI interface.
  6. Press **Enter** to determine which channel of the interface to highlight, match the `PCI Bus`, `PCI Dev`, and `PCI Func` values on this screen to the `Bus #`, `Dev #`, and `Func #` values from the `info io` command.
- 



**CAUTION:** Do not select the **<Global Properties>** option on the main menu.

---



**TIP:** To move the cursor in the EFI SCSI Setup Utility, use the following keys:

- Arrow keys: `↑` `↓` `←` `→`
  - Alternate keys:
    - H** = left
    - J** = down
    - K** = up
    - L** = right
    - I** = home
    - O** = end
- 

The Adapter Properties screen for this channel of the SCSI interface appears.

7. Be sure the utility is running for the channel of the SCSI interface by comparing the values shown for PCI Bus, PCI Device, and PCI Function to the Bus #, Dev #, and Fnc # values from the `info io` command.



**CAUTION:** Do not change the value for any of these fields on the Adapter Properties screen:

- Auto Termination
- SCSI Parity
- SCSI Bus Scan Order
- Spinup Delay (Secs)

Changing any of these fields can cause unpredictable results.

**CAUTION:** Do not change the value for *any* of these fields on the Device Properties screen:

- Scan Id
- Scan LUNs > 0
- Disconnect
- SCSI Timeout
- Queue Tags
- Format
- Verify

Changing any of these fields can cause unpredictable results.

8. Display the SCSI parameters listed below for the channel of the SCSI interface and change the parameters if necessary, or restore its SCSI parameters to their default values.
  - SCSI ID
  - Maximum data transfer rate
  - Bus width
  - Whether the SCSI interface is bootable (driver support)
  - Avoid bus resets (secondary cluster server)
  - Restore Defaults
9. Use the arrow keys to navigate to the appropriate SCSI parameter.
10. Use the plus (+) and minus (-) keys to scroll through the values until the value you want appears.
11. Press **Esc** to exit the **Adapter Properties** screen.
12. Move the cursor to the action (cancel, save, or discard) you want to take, and press **Enter**. Select one of the following options:
  - Cancel the exit to stay on the Adapter Properties screen for the channel of the SCSI interface.
  - Save the changes you made, then exit the screen.
  - Discard the changes you made, then exit the screen.

If you select `cancel`, you remain in the Adapter Properties screen for the channel of the SCSI interface. You can still change the channel's parameters.

If you select `save` or `discard`, you go to the EFI SCSI Setup Utility main menu.



**CAUTION:** Do not select the `<Global Properties>` option on the main menu.

13. Press **Esc** to exit the main menu and the EFI SCSI Setup Utility.
14. Select the option for exiting the utility.
15. When you are prompted, press **Enter** to stop the SCSI interface; you are now at the EFI Shell prompt.
16. At the EFI Shell prompt, enter the `reset` command. The system starts to reboot. This is required to cause the new SCSI setting.

# Using the Boot Option Maintenance Menu

This menu allows you to select console output and input devices as well as various boot options. It contains the following items:

- Boot From File
- Add Boot Entry
- Edit Boot Entry
- Remove Boot Entry
- Edit OS Boot Order
- AutoBoot Configuration
- BootNext Configuration
- Driver Configuration
- Console Configuration
- System Reset



**NOTE:** Your server may have different options available based on the server configuration and installed hardware components.

These items are described in the following sections. The following selections are available on all menus:

- **Help:** Displays the help available for the command.
- **Exit:** Returns to the main Boot Options Maintenance menu.
- **Enter:** Selects an item after using the arrow keys to highlight the item.
- **Save Settings to NVRAM:** Saves your changes.

## Paths

All devices in servers are represented by paths in the EFI Shell. To identify the correct slot or disk drive, use the following tables.



**NOTE:** The device path might be different depending on which I/O riser is installed in your server.

**Table C-3 PCI Slots and Device Path**

Slots	Device Path
1 PCI	Acpi(HWP0002,400)/pci(1 0)
2 PCI	Acpi(HWP0002,300)/pci(1 0)
3 PCI	Acpi(HWP0002,200)/pci(1 0)
4 PCI	Acpi(HWP0002,600)/pci(1 0)

**Table C-4 Disk Drives and Device Path**

Disk Drive	Device Path
SCSI Disk (HDD1)	Acpi(HWP0002,100)/Pci(1 1)/Scsi(Pun2,Lun0)
SCSI Disk (HDD2)	Acpi(HWP0002,100)/Pci(1 0)/Scsi(Pun1,Lun0)
SCSI Disk (HDD3)	Acpi(HWP0002,100)/Pci(1 0)/Scsi(Pun0,Lun0)
Removable Media Boot	Acpi(HWP0002,0)/Pci(2 0)/ATA

## Boot From File

Use this option to manually run a specific application or driver.



---

**NOTE:** This option boots the selected application or driver one time only. When you exit the application, you return to this menu.

---

This option displays the file systems that are on your server or workstation and lets you browse these file systems for applications or drivers that are executable. Executable files end with the .efi extension. You can also select remote boot (LAN) options that have been configured on your network.

For example:

```
Boot From a File. Select a Volume
NO VOLUME LABEL [Acpi(HWP0002,0)/Pci(2|0)/Ata(Primary,Master)/CDROM
CD_FORMAT [Acpi(HWP0002,0)/Pci(2|0)/Ata(Secondary,Master)/CDROM
Removable Media Boot [Acpi(HWP0002,500)/Pci(2|0)/Ata(Secondary,Master)
Load File [EFI Shell [Built-in]]
Load File [Acpi(HWP0002,0)/Pci(3|0)/Mac(00306E4C4F1A)]
Exit
```

Where:

- **NO VOLUME LABEL:** A hard drive. When you format a hard drive, the EFI tools provide an option to LABEL the disk. In this example, the volume is not labelled.
- **CD\_FORMAT:** The label created for the disk currently inside the DVD drive.
- **Removable Media Boot:** Allows you to boot from a removable media drive (CD/DVD drive). This option does not support booting from a specific file on a specific CD.
- **Load Files:** The EFI Shell and the LAN.

## Add a Boot Option

Use this option to add items to the EFI boot menu.

This option displays the file systems that are on your system and lets you browse these file systems for applications or drivers that are executable. Executable files end with the .efi extension. You can also select remote boot (LAN) options that have been configured on your network. The option you have selected is added to the EFI boot menu.

If you add a new drive to your system, you must manually add its boot options list if you want to make it a bootable device.

When adding a boot option that already exists in the Boot Manager list of boot options, you can choose whether to create a new option or modify the existing one. If you:

- To modify an existing option, change the boot option name or add boot option arguments to the existing option.



---

**NOTE:** If you create a new boot option for an already existing option, multiple instances of the same boot option exist.

---

For example:

```
Add a Boot Option. Select a Volume
NO VOLUME LABEL [Acpi(HWP0002,0)/Pci(2|0)/Ata(Primary,Master)/CDROM
Removable Media Boot [Acpi(HWP0002,0)/Pci(2|0)/Ata(Secondary,Master)
Load File [EFI Shell [Built-in]]
Load File [Acpi(HWP0002,0)/Pci(3|0)/Mac(00306E4C4F1A)]
Exit
```

Where:

- **NO VOLUME LABEL:** A hard drive. You can search through the disk for bootable applications to add to the Boot Manager list of Boot options.
- **Removable Media Boot:** Treats the removable media as a bootable device.
- **Load File EFI Shell:** Adds a new instance to the EFI Shell. Load File with the MAC address adds a network boot option.
- **Load File with the MAC address:** Adds a network boot option.

## Edit Boot Entry

Use this option to edit the boot options on the EFI boot menu.



---

**NOTE:** This does not delete any files, applications or drivers from your server.

---

This option displays a list of boot options that are configured on your server. The names match the options on the main Boot Manager menu.

If you remove a drive from your server, you must manually delete it from the boot options list.

- To delete an item from the list, use the arrow keys to highlight the item and press **Enter**.
- To remove all of the entries from the EFI boot menu, select **Delete All Boot Options**. This setting may be used as a security device on servers that are accessed remotely.

## Delete Boot Option(s)

Use this option to remove boot options from the EFI boot menu.



---

**NOTE:** This does not delete any files, applications, or drivers from your system.

---

This option displays a list of boot options that are configured on the system. The names match the options on the main Boot Manager menu.

If you remove a drive from the system, you must manually delete it from the boot options list.

- To delete an item from the list, use the arrow keys to highlight the item and press **Enter**.
- To remove all of the entries from the EFI Boot menu, select **Delete All Boot Options**. This setting can be used as a security device on systems that are accessed remotely.

## Change Boot Order

Use this option to remove boot options entry. The order in which options are listed in the EFI boot menu also reflects the order in which the server attempts to boot. If the first boot option fails, the server tries booting the second, then the third, and so forth, until a boot option succeeds or until all options have failed.

For example, if you normally boot using a configuration on your LAN but would like to boot from a local hard drive if the LAN is unavailable, move the LAN boot option to the top of the list, followed by the hard drive boot option.

The menu lists boot options that currently exist in the main Boot Manager menu. You can change the priority of the items by moving them up or down in the list:

- Press **U** to move an option up.
- Press **D** to move an option down.
- Select **Save Settings to NVRAM** to modify the order in the Boot Manager menu, which modifies the order that the Boot Manager attempts to boot the options.
- The items at the bottom of the screen are descriptions of the selected option.

```
Change boot order. Select an Operation
EFI Shell [Built-in]
Current OS
Save Settings to NVRAM
Help
Exit

VenHw (D65A6B8C-71E5-4DF0-A909-F0D2992B5AA9)
Boot0000
```

For example:

## Manage BootNext Setting

Use this option to run the selected boot option immediately upon entering the main Boot Manager menu. This option is useful for booting an option that only needs to be booted once, without



changing any other setting in the main Boot Manager menu. This is a one-time operation and does not change the permanent system boot settings.

This option displays the file systems that are on your system and lets you browse these file systems for applications or drivers that are executable. Executable files end with the `.efi` extension. You can also select remote boot (LAN) options that have been configured on your network.

To restore the default BootNext setting, select **Reset BootNext Setting**.

For example:

```
Manage BootNext setting. Select an Operation
EFI Shell [Built-in]
Current OS
Reset BootNext Setting
Save Settings to NVRAM
Help
Exit

VenHw (D65A6B8C-71E5-4DF0-A909-F0D2992B5AA9)
Boot0000
```

## Set AutoBoot TimeOut

Use this option to set the amount of time the system pauses before attempting to launch the first item in the Boot Options list.

For example:

```
Set Auto Boot Timeout. Select an Option
Set Timeout Value
Delete/Disable Timeout
Help
Exit
```

Interrupting the timeout during the countdown stops the Boot Manager from loading any boot options automatically. If there is no countdown set, you must select boot options manually.

- To set the auto boot timeout value, in seconds, select **Set Timeout Value** and enter the desired value.
- To disable the timeout function, select **Delete/Disable Timeout**.



**NOTE:** When this option is selected, the server does not automatically boot. The server stops at the EFI boot menu and waits for user input.

---

## Select Console Configuration

Use this option to define the devices that are used to provide input and output to the system console. This list includes the VGA monitor and a serial port for directing input and output to a terminal emulation package.



**NOTE:** If you install a modem in your server, make sure you disable the modem serial port in both the Active Console Input and Active Console Output device lists.

**NOTE:** Some operating systems support multiple consoles, such as a simultaneous serial and VGA output. See your OS documentation to determine how many consoles are supported with your server. Multiple consoles are not supported for HP-UX or Windows (use the Smart Setup CD to switch between COM A and the iLO 2 MP on Windows systems).

---

Figure C-3 shows an example of the console configuration screen.

**Figure C-3 Console Configuration**

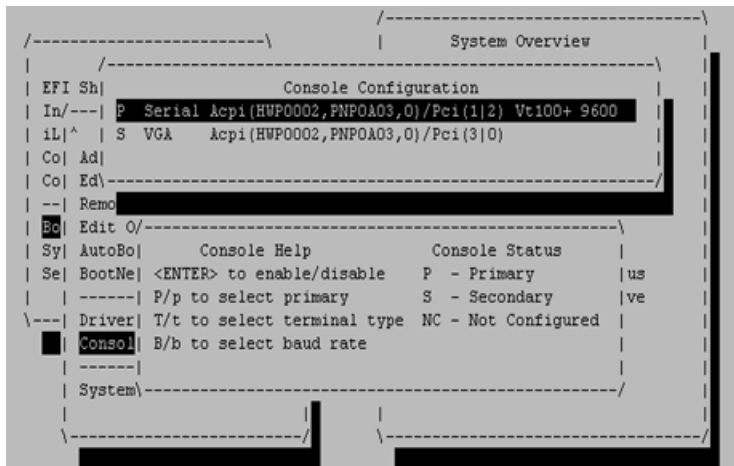

This menu is identical to Console Error Devices. HP Integrity servers do not support different configurations for Input, Output, and Error console. For correct operation, you must do the following:

- When changes are made to Input, Output, or Error console menus, you must make the identical change in all menus.
- When changing serial devices, you must also make changes to Input, Output, and Error menus.

To define the devices that are used to provide input and output to the system console, follow these steps:

1. Select the console (P Serial or S VGA).

Each option is identified with an EFI device path. Not all options are available, depending on the configuration of the server and the options purchased.



**NOTE:** Device paths might differ slightly on different servers.

2. Select the console configuration option.

On both serial device examples, UART 9600 indicates the current baud rate of the serial device (can be changed with the EFI Shell baud command), VenMsg Vt100+ is the current emulation type (several different terminal emulation protocols are supported).

Only one terminal emulation type can be selected for each serial console, but multiple serial consoles can be selected at a time.

## Select Active Standard Error Devices

Use this option to define the devices that display error messages from the system console.

This menu is identical to the Console Output Devices menu. The server does not support different configurations for Output and Error console. When you make changes to either Output or Error console menus, you must make the identical change in the other menu. When you change serial devices, you must make changes to Output, Input, and Error menus for proper operation.

## Using the System Configuration Menu

The **System Configuration** menu on servers with the latest version of the EFI firmware supported includes the following options:



**NOTE:** To determine the current firmware version, execute the following EFI `info fw` command at the EFI Shell prompt.

- Security/Password Menu: Enables you to change the administrator and user passwords.
- Advanced System Information Menu: Displays information about system and component configuration.

- Set System Date: Enables you to modify the system date.
- Set System Time: Enables you to modify the system time.
- Reset Configuration to Default: Enables you restore system settings to their original configuration.
- Help: Displays additional information about the available options.
- Exit: Returns to the EFI startup menu.

## Security/Password Menu

You can set administrator and user passwords to provide different levels of access to the system firmware.

## Resetting Passwords

If you forget your passwords, reset them by running using the iLO 2 MP `<Ctrl+N>rscommand`. This command resets the iLO 2 MP and resets the password.



---

**NOTE:** You can only run this command when directly connected to the server.

---

## Advanced System Information

The **Advanced System Information** menu displays information about server and component configuration.

## Set System Time

Set System Time lets you modify the server time.

## Set System Date

Set System Date lets you modify the server date.

## Set User Interface

Set User Interface lets the user change the legacy boot manager user interface.

## Set System Wake-On LAN

Set System Wake-On LAN lets the user enable/disable the server Wake-On\_LAN settings.

## Set System Defaults

Set System Defaults lets you select server default settings.

# Integrated Lights Out 2 Management Processor

The integrated Lights Out 2 Management Processor (iLO MP) for entry-level Integrity servers is an autonomous management subsystem embedded directly on the server. It is the foundation of the server High Availability (HA), embedded server, and fault management. It also provides system administrators secure remote management capabilities regardless of server status or location. The iLO 2 MP is available whenever the system is connected to a power source, even if the server main power switch is in the off position.

HP has used several different names over the years to describe the management functionality embedded in their servers, including “the management processor.” In addition, HP uses the term “management processor” to refer to any embedded microprocessor that manages a system. Management processor is a descriptive term (such as “server”), and iLO, is a brand name, or label (such as “Integrity”).

Remote access is the key to maximizing efficiency of administration and troubleshooting for enterprise servers. Integrity servers have been designed so all administrative functions that can be performed locally on the machine, can also be performed remotely. iLO enables remote access to the operating system console, control over the server power and hardware reset functionality, and works with the server to enable remote network booting through a variety of methods.

iLO 2 refers to an Integrated Lights Out 2 Management Processor (iLO 2 MP) with the latest advanced digital video redirection technology. This new feature gives you a higher performance graphics console redirection experience than with the previous iLO.

For information on the iLO 2 MP, see the *HP Integrity Integrated Lights-Out 2 Management Processor Operations Guide*.

---

# Index

## A

- ac power
  - Data Center server, 65
  - input, 65
  - Office Friendly server, 65
- ac power inputs
  - A0, 65
  - A1, 65
  - B0, 65
  - B1, 65
- ACPI
  - defined, 26
- activity LED, 134
- adapter
  - path, 234
  - slot number, 234
- Advanced Configuration and Power Interface (*see* ACPI)
- autoboot, 88

## B

- backup (*see* server backup)
- block diagrams
  - I/O subsystem, 21
  - system, 20
- boot
  - EFI boot manager, 212
- boot configuration menu, 238
- boot option
  - delete, 240
- boot options list, 87
  - adding HP-UX, 89
  - adding Linux, 101
  - adding Windows, 97
- booting
  - HP-UX, 88
    - LVM maintenance mode, 92
    - single-user mode, 91
  - Linux, 101
  - OpenVMS, 93
  - Red Hat Linux, 102
  - SuSE Linux, 103
    - from EFI Shell, 103
  - Windows, 97

## C

- checklist, server installation, 43
- CM command, 79
- cold-swappable
  - components, listed, 142
  - defined, 142
- command mode (*see* CM)
- commands
  - devtree
    - EFI-capable devices and controller handles, displaying, 235

- drvcfg
  - EFI configurable components, displaying, 235
  - EFI driver handle, determining, 236
  - EFI SCSI setup utility, starting, 236
- info
  - adapter path, 234
  - adapter slot number, 234
- component classification, 141
- components
  - cold-swappable, defined, 142
  - hot-pluggable, defined, 141
- configurable components, EFI capable, displaying, 235
- console problems occur, 86
- console session
  - determining connection method, 70
  - using VGA, 78
- controller handle, 235
- controls
  - front panel, functions, 28
- cooling, 24
  - (*see also* fans)
- cooling zones, 148, 149
- cover, top
  - remove, 48, 143
  - removing and replacing, 48, 143–144
  - replace, 63, 144, 209
  - thermal considerations, 143
- CPU (*see* processor)
- CRU list (*see* customer replaceable units list)
- customer replaceable units list, 201

## D

- Data Center server
  - introduction, 20
- data paths
  - ACPI, 238
- devtreecommand
  - EFI-capable devices and controller handles, displaying, 235
- DHCP
  - and DNS, 71
  - defined, 71
- DHCP-enabled security risk, 76
- dimensions
  - server, 37
- DIMM (*see* memory)
- disk drive
  - activity LED, 30
  - activity LED, location, 30
  - activity LED, states, 30
  - LEDs, 30–31
  - load order, 156
  - status LED, 30
  - status LED, location, 30
  - status LED, states, 30
- DNS

- defined, 71
- Domain Name Server (*see* DNS)
- drvcfgcommand
  - EFI configurable components, displaying, 235
  - EFI driver handle, determining, 236
  - EFI SCSI setup utility, starting, 236
- dual-core processing
  - defined, 52, 175
- dual-core processor (*see* processor)
- DVD drive
  - introduction, 29
  - removing, 157
  - replacing, 157
- DVD problems occur, 85
- DVD+RW drive (*see* DVD drive)
- Dynamic Host Configuration Protocol (*see* DHCP)

## E

- EFI
  - capable devices
    - and controller handles, displaying, 235
  - commands, 213–215
  - configurable components, displaying, 235
  - defined, 26
  - driver handle, determining, 236
  - info all command, 185, 196
- EFI boot manager, 212
- EFI commands
  - info io, 209
  - info warning, 209
  - (*see also* viewing warnings)
- EFI SCSI setup utility
  - starting, 236
- EFI/POSSE, 215–231
- EFI/POSSE commands, 215
- electrical specifications, 37
- emulation device
  - configuring, 73
- Extensible Firmware Interface (*see* EFI)
- extensible firmware interface, (*see* EFI)
- external health
  - LED, 29
- external health LED
  - definition, 113
  - location, 28

## F

- fan cooling zones, 148, 149
- fan/display board
  - functionality, 170
  - removing, 171
  - replacing, 172
- fans
  - introduction, 24
  - introduction, office friendly, 25
  - N+1 defined, 24
  - removing, 150
  - replacing, 152
- firmware

- defined, 26
- introduction, 26
- operating system requirements, 26
- front control panel
  - LEDs, 28–29
- front display panel (*see* System Insight Display)
  - introduction, 29
- front panel
  - controls, 28
  - functional overview, 27
- FRU list (*see* customer replaceable units list)

## H

- handle
  - controller, 235
- hard disk drive (*see* disk drive)
- hard disk drive modules, 134
- hard drive
  - removing, 155
  - replacing, 46, 156
- hard drive filler
  - removing, 154
  - replacing, 155
- hard drive problems occur, 86
- Hard Drive, Hot-Plug, 45
  - Replace, 46
- HDD (*see* disk drive)
- hot-plug disk drive (*see* disk drive)
- hot-plug hard drive (*see* hard drive)
- hot-plug hard drive filler (*see* hard drive filler)
- hot-pluggable
  - components, listed, 142
  - defined, 141
- Hot-swap disk drive module, 134
- hot-swap fan (*see* fans)
- hot-swap power supply (*see* power supply)
- hot-swappable
  - components, listed, 141
  - defined, 141

## I

- I/O backplane (*see* I/O board assembly)
- I/O backplane upgrade
  - overview, 204
  - tools required, 204
- I/O board (*see* I/O board assembly)
- I/O board assembly
  - removing, 159, 182, 184
  - replacing, 160, 183, 184
- I/O card (*see* PCI-X/PCIe card)
- I/O cards
  - verifying, 209
- I/O subsystem, 21, 22
  - (*see also* core I/O board)
  - (*see also* I/O board assembly)
  - (*see also* I/O board assembly)
  - block diagram, 21
  - introduction, 21, 22
- iLO 2 MP

- LAN LEDs, 33
- LAN link speed LEDs, 33
- LAN link status LEDs, 33
- logging in, 74
- Main Menu, 74
- PC command, 78, 79
- status LEDs, 33
- info command
  - adapter path, 234
  - adapter slot number, 234
- initial observations
  - interval one, 66
  - interval three, 66
  - interval two, 66
- integrated lights-out 2 management processor (*see* iLO 2 MP)
- intermittent server problems, 85
- internal health
  - LED, 29
- internal health LED
  - definition, 113
  - location, 28
- IP address
  - iLO
    - how iLO acquires, 70
- L
- LEDs, 134
  - disk drive, 30–31
  - DVD, activity, 31
  - external health, 29
  - front control panel, 28–29
  - internal health, 29
  - MP LAN link speed, 33
  - MP LAN link status, 33
  - MP status, 33
  - power button, 29
  - power supply, 34
  - rear panel UID, 35
  - system health, 28
  - System Insight Display, 29
  - UID button, 28
- load order
  - memory, 51, 174
  - processor, 53, 176
- logging in to the iLO 2 MP, 74
- M
- management processor (*see* iLO 2 MP) (*see* iLO 2 MP)
- mass storage, 26
  - (*see also* SAS)
  - introduction, 26
- mass storage subsystem (*see* mass storage)
- memory
  - installation conventions, 51, 174
  - installing, 52, 174
  - introduction, 23
  - load order, 51, 174
  - removing, 173
  - supported DIMM sizes, 51, 174
- midplane board
  - removing, 196
  - replacing, 198
- MP, 74, 129, 243 (*see* iLO 2 MP) (*see* iLO 2 MP)
  - (*see also* iLO 2 MP)
  - controls, ports, and LEDs, 32–33
  - functional overview, 32
  - reset button, 33
- MPS optimization (*see* PCIe MPS optimization)
- N
- N+1
  - defined, 24
- N+1 capability, 65
- O
- Office Friendly Server
  - fan remove and replace, 149
- Office Friendly server
  - introduction, 20
- operating system
  - will boot or will not boot, 85
- operating systems supported, 87
- Option ROM Configuration for Arrays (*see* ORCA)
- ORCA, 232
- OS (*see* operating system)
- P
- PAL
  - defined, 26
- paths
  - ACPI, 238
- PC command, 78, 79
- PCI card (*see* PCI-X/PCIe card)
- PCI-X card (*see* PCI-X/PCIe card)
- PCI-X slots, 35
- PCI-X/PCIe card
  - offline installation, 168, 169, 209
  - offline removal, 166, 169, 206
- PCIe MPS optimization, 22–23
  - enabling, 23
  - support, 22
- PCIe MPS optimize
  - ioconfig command, 221
- PCIe slots, 35
- PCIe/PCI-X card
  - installation, 60
- Pedestal
  - Converting from Rack Mount, 64
- POSSE
  - defined, 26
- power, 25
  - (*see also* power supply)
  - full state, defined, 78
  - introduction, 25
  - off state, defined, 78
  - PR command, 78
  - sources, 65

- standby state, defined, 78
- states, 65, 78
- power button, 84
  - function, 28
  - LED, 29
- power problems, 84
- power reset command (*see* PR)
- power subsystem (*see* power)
- power supply
  - LEDs, 34
  - load order, 47, 153
  - removing, 153
  - replacing, 154
- Power Supply, Hot-Swap, 47
  - Replace, 48
- powering off the server, 79
  - manually, 79
  - using the iLO 2 MP PC command, 79
- powering on the server, 78–79
  - manually, 79
  - using the iLO 2 MP PC command, 79
- PR command, 78
- Pre-OS System Environment (*see* EFI/POSSE)
- Pre-OS System Startup Environment (*see* POSSE)
- processor
  - configuration options, 52, 175
  - installing, 52, 180
  - introduction, 23
  - load order, 53, 176
  - removing, 176
  - required service tools, 53, 176
  - restrictions, 53, 176
- Processor Abstraction Layer (*see* PAL)

## R

- Rack
  - Installing Into, 64
- rack
  - anti-tip features, 142
  - extending the server from, 142
  - extension clearance, 142
  - inserting the server into, 143, 209
- rack-mount server
  - accessing, 142
- rackless (*see* tower-mount)
- rear panel
  - functional overview, 31
- Remove and Replace
  - Hard Drive, Hot-Plug, 45
  - PCI-X/PCIe Cards, 35
  - PCI/PCI-X Cards, 58
  - Power Supply, Hot-Swap, 47
- reset button
  - MP, 33

## S

- safety information, 204
- safety information, general, 42, 140
- SAL

- defined, 26
- SAS
  - features and capabilities, 193
  - technology overview, 193
- SAS backplane
  - removing, 194
  - replacing, 195
- SAS I/O card
  - removing, 188
  - replacing, 191
- SCSI
  - setup utility, 233
  - specifying parameters, 233
- SCSI adapter
  - path, 234
- security risk with DHCP enabled, 76
- serial-attached SCSI (*see* SAS)
- server
  - installation checklist, 43
- server backup, 205
- service tools, 140
- shut down
  - HP-UX, 93
  - Linux, 104
  - Windows, 100
    - from command line, 100
- static IP address
  - assigning with ARP Ping, 72
  - assigning with LC command, 73
- storage (*see* mass storage)
- supported operating systems, 87
- System Abstraction Layer (*see* SAL)
- system battery
  - recording configuration settings before removing, 185, 196
  - removing, 185
  - replacing, 186
  - reset system settings after replacing, 186
- system block diagram, 20
- system board
  - ports, described, 33
- system configuration menu, 242
- system fans (*see* fans)
- system health
  - LED, 28
- System Insight Display
  - introduction, 29
  - LEDs, 29
- system LAN
  - link speed LEDs, 34
  - link status LEDs, 34
  - ports, 34

## T

- top cover (*see* cover, top)
- tower-mount server
  - accessing, 143
- troubleshooting
  - console problems occur, 86



- DVD problems occur, 85
- hard drive problems occur, 86
- methodology, 83
- operating system, 85

## U

- UID button
  - function, 28
  - LED, 28
- Unpacking, Inspecting for Damage, 44
- UUID
  - on fan/display board, 171

## V

- VGA console session, 78
- viewing warnings, 209

## W

- wake-on-LAN, 35
- web interface
  - interacting with, 76
- weight
  - server, 37