

Installation Guide

HP 9000 rp7420 Server

Fourth Edition



Manufacturing Part Number : A7025-96014

October 2006

Printed in the U.S.A.

© Copyright 1979-2006 Hewlett-Packard Development Company, L.P.

Legal Notices

© Copyright 2006 Hewlett-Packard Development Company, L.P.

The information contained herein is subject to change without notice.

The only warranties for HP products and services are set forth in the express warranty statements accompanying such products and services. Nothing herein should be construed as constituting an additional warranty. HP shall not be liable for technical or editorial errors or omissions contained herein.

Revision History

- | | |
|----------------|-----------------------------------------------------------------------------------------------------|
| First Edition | Initial release. December 2003. P/N was A7025-96005 |
| Second Edition | Added/Modified PCI-X/PCI tables in Chapter 3. Updated graphics. Minor edits. June 2004. |
| Third Edition | Extensive edits to Chapters 1, 2, 3, & 4 to more closely align with a higher quality TCE. May 2005. |
| Fourth Edition | Updated supported PCI/PCI-X I/O card list. October 2006. |

1. Introduction

Overview	2
Front Panel	7
Cell Board	7
System Backplane	7
I/O Subsystem	8
MP/SCSI Core I/O Board	9
Procurium LAN/SCSI Board	9
Internal Disk Devices for the HP 9000 rp7420 Server	10
Mass Storage (Disk) Backplane	10

2. Unpacking the Server

Inspecting the Server Cabinet	12
Receiving the Server Cabinet	13
Securing the Cabinet	16
Stand Alone and To Be Racked Systems	17
Manual Lifting	18
Using the RonI Model 17000 SP 400 Lifting Device	22
Wheel Kit Installation	26

3. Installing Accessories

Installing Add-On Products	34
Embedded Mass Storage	34
PCI/PCI-X Card Cage Assembly I/O Cards	36

4. Cabling and Power Up

Voltage Check	42
Voltage Check (Additional Procedure)	46
Connecting AC Input Power	48
MP/SCSI Core I/O Connections	50
MP/SCSI Core I/O Board Connections	50
LAN/SCSI Connections	50
Management Processor Access	50
Setting Up the Customer Engineer Tool (PC)	51
Setting CE Tool Parameters	51
Connecting the CE Tool to the Local RS232 Port on the MP	52
Turning on Housekeeping Power and Logging in to the MP	53
Configuring LAN Information for the MP	55
Accessing the Management Processor via a Web Browser	57
Verifying Presence of the Cell Boards	59
Booting the HP 9000 rp7420 Server	60
Selecting a Boot Partition using the Management Processor	61
Verifying the System Configuration using Boot Console Handler	61
Booting HP-UX using Boot Console Handler	61
Adding Processors with Instant Capacity On Demand	62
Using the Checklist	63

Contents

Index67

Table 1-1. PCI-X Slot Types	9
Table 2-1. Wheel Kit Packing List	26
Table 2-2. Caster Part Numbers	29
Table 3-1. HP 9000 rp7420 Server PCI-X I/O Cards	36
Table 3-2. HP 9000 rp7420 Server PCI I/O Cards	36
Table 4-1. Single Phase Voltage Examples	43
Table 4-2. Factory-Integrated Installation Checklist	63

Figure 1-1. HP 9000 rp7420 Server with mounted bezel (Front View)	3
Figure 1-2. Right-Front View of HP 9000 rp7420 Server	5
Figure 1-3. Left-Rear View of HP 9000 rp7420 Server	6
Figure 1-4. Front Panel Display	7
Figure 1-5. Internal Disks	10
Figure 2-1. Removing the Polystraps and Cardboard	13
Figure 2-2. Removing the Shipping Bolts and Plastic Cover	14
Figure 2-3. Preparing to Roll Off the Pallet.	15
Figure 2-4. Securing the Cabinet	16
Figure 2-5. Positioning the Lift handles	19
Figure 2-6. Inserting the Shoulder Washer Pins Into the Server Chassis.	20
Figure 2-7. Lift Handles Mounted	21
Figure 2-8. RONI Lifter	22
Figure 2-9. Server with Shipping Box Removed	23
Figure 2-10. Remove Cushions for Lift Access	24
Figure 2-11. Raising a Server Off the Pallet	25
Figure 2-12. Component Locations	27
Figure 2-13. Left Foam Block Position	28
Figure 2-14. Right Foam Block Position	28
Figure 2-15. Foam Block Removal.	29
Figure 2-16. Attaching a Caster to the Server	30
Figure 2-17. Securing Each Caster Cover to the Server	31
Figure 2-18. Completed Server	32
Figure 3-1. Internal Disks	34
Figure 3-2. PCI I/O Slot Details	39
Figure 4-1. Voltage Reference Points for IEC 320 C19 Plug.	43
Figure 4-2. Safety Ground Reference Check—Single Power Source	44
Figure 4-3. Safety Ground Reference Check—Dual Power Source	45
Figure 4-4. Wall Receptacle Pinouts.	46
Figure 4-5. Power Cord Configuration	48
Figure 4-6. Power Source versus. Power Distribution	49
Figure 4-7. MP Main Menu	54
Figure 4-8. The lc Command Screen	55
Figure 4-9. The ls Command Screen	56
Figure 4-10. Example sa Command	57
Figure 4-11. Browser Window	58
Figure 4-12. The du Command Screen	59

1 Introduction

The HP 9000 rp7420 Server is a member of the HP business-critical computing platform family: a mid-range, mid-volume server, positioned as a performance upgrade to the HP 9000 rp7410 product. The HP 9000 rp7420 Server shares the same hardware as the HP 9000 rp7410 with changes to the cell board, CPU modules, core I/O, and the PCI-X backplane.

Overview

The HP 9000 rp7420 Server is a 10U, 8-socket Symmetric Multi-Processing, rack-mount server that accommodates up to 64 GB of memory; PCI-X I/O, and internal peripherals, including disks and DVD/tape. Its high availability features include N+1 hot-pluggable fans and power, redundant power cords, and hot-pluggable PCI-X cards and internal disks. It currently uses dual core, PA-RISC processors. Features of the server include:

- Up to 64GB of physical memory using HP supported 2GB dual in-line memory modules (DIMMs).
- Up to 16 processors with a maximum of eight processor modules per cell board with a maximum of two cell boards. There are four processor module sockets per cell board and each socket will accept a dual-core processor so each cell will support up to eight processors.
- One cell controller (CC) per cell board.
- All CPUs and cell controllers on the cell boards are cooled with turbo cooler fans.
- Four embedded hard disk drives. Available sizes are 36GB, 73GB, and 146GB drives.
- One internal DVD drive or one 40GB DDS-4 DAT drive.
- Two front chassis mounted N+1 fans.
- Two rear chassis mounted N+1 fans.
- Six N+1 PCI-X card cage fans.
- Two N+1 bulk power supplies.
- Sixteen PCI-X slots divided into two partitions. Each partition can accommodate up to eight PCI cards.
- Two MP (Management Processor-MP)/SCSI Core I/O cards.
- One failover service processor per core I/O card.
- Four 220 VAC power receptacles. Two are required and the other two provide power source redundancy.

Figure 1-1 **HP 9000 rp7420 Server with mounted bezel (Front View)**

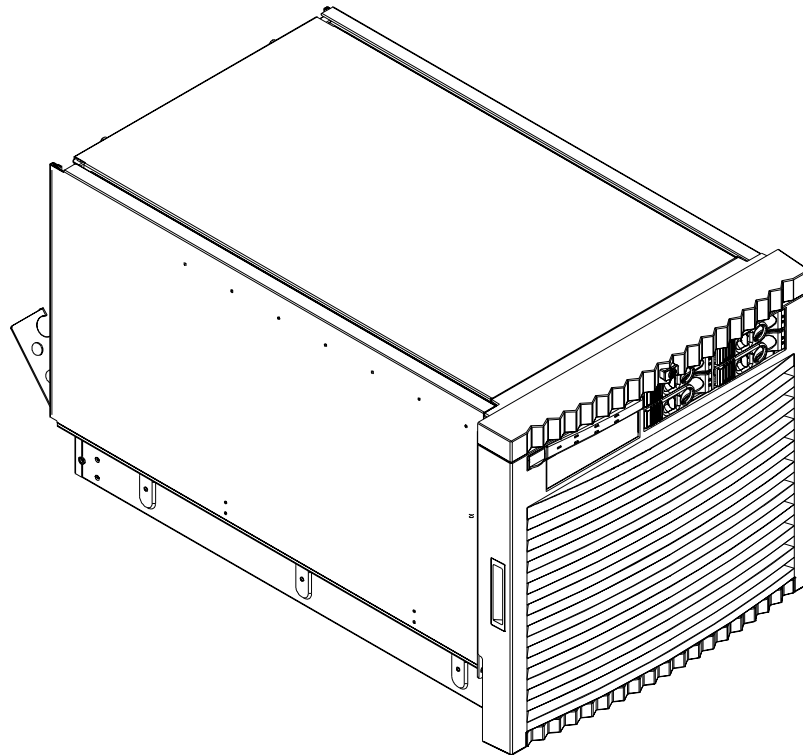

- *Depth:* Defined by cable management constraints to fit into standard 36-inch deep racks:
 - 25.5 inches from front rack column to PCI connector surface
 - 26.7 inches from front rack column to MP Core I/O connector surface
 - 30 inches overall package dimension, including 2.7 inches protruding in front of the front rack columns
- *Width:* 44.45 cm (17.5 inches), constrained by EIA standard 19 inch racks
- *Height:* 10U – 0.54 cm = 43.91 cm (17.287 inches). Fitting four server units per 2 m rack and upgrade of current 10U height products in the future are the main height constraints.

See Figure 1-2 on page 5 for component location.

The mass storage section located in the front allows access to the hard disk drives without removal of the bezel (bezel removed in figure). Removing the bezel allows access to the removable media drive, the front fans and the bulk power supplies. The mass storage bay accommodates one 5.25-inch removable media drive and up to four 3.5-inch hard disk drives. The front panel display, containing LEDs and the system power switch, is located directly above the removable media drive bay.

Below the mass storage section and behind the removable bezel are two PCI DC-to-DC power supplies. Each PCI power supply will provide power requirements for only one PCI-X I/O partition.

The PCI-X card section, located in upper rear of server, is accessed by removing top cover (cover shown removed).

Six PCI-X OLR fan modules are located opposite the PCI-X card bulkheads. They are housed in blue plastic carriers.

Four OLR N+1 system fan modules are externally attached to the chassis. Two are mounted on the front surface of the chassis and two are mounted on the rear surface of the chassis.

When facing the front of the server, the cell boards are located on the right side of the product behind a removable side cover (cover removed in figure). Rack cabinet front doors are often times hinged on the left, which restricts the cell board to be extracted or inserted from the right.

The bulk power supply is partitioned through the use of a sealed metallic enclosure located in the bottom of the server. This enclosure houses the N+1 fully redundant bulk power supplies. These power supplies are installed from the front of the server after removing the front bezel.

Figure 1-2 Right-Front View of HP 9000 rp7420 Server

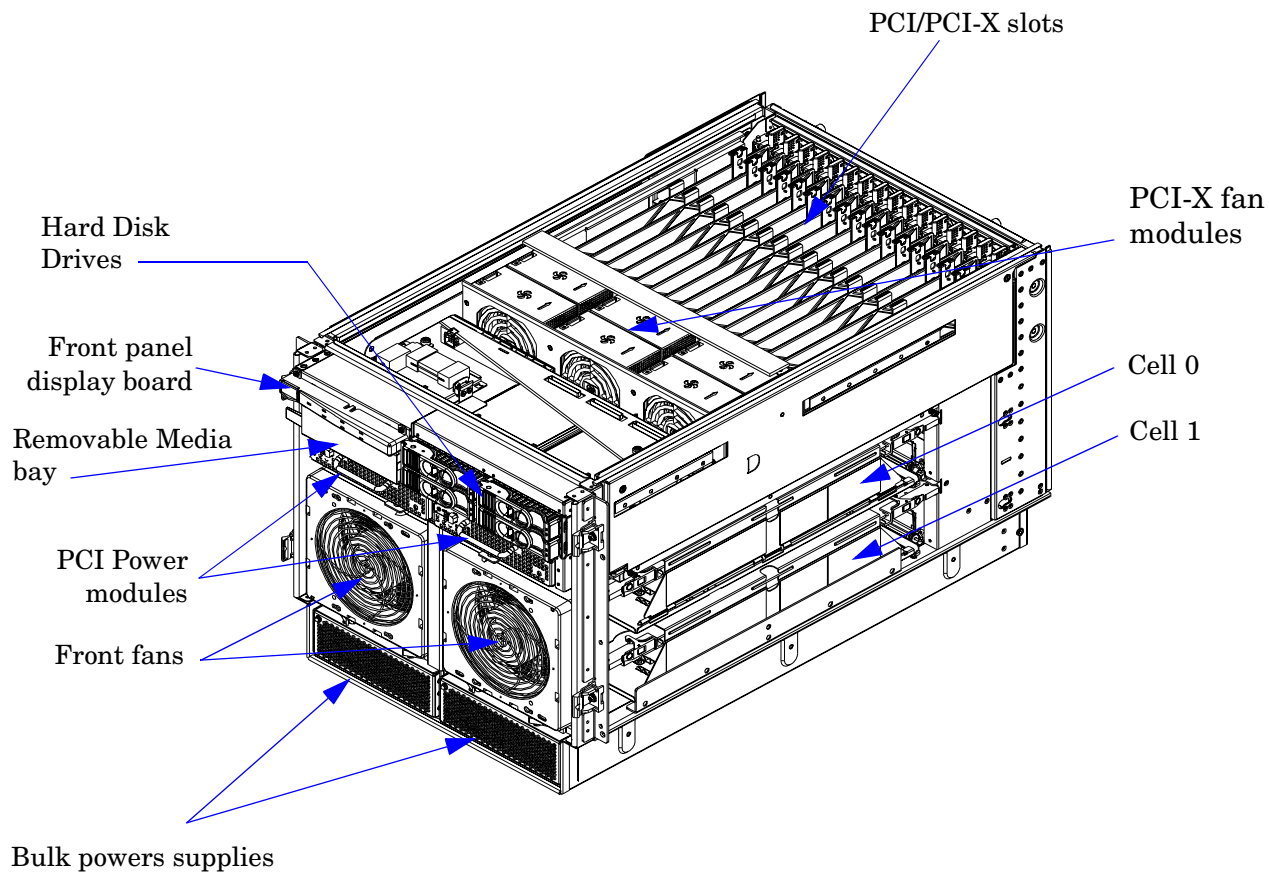
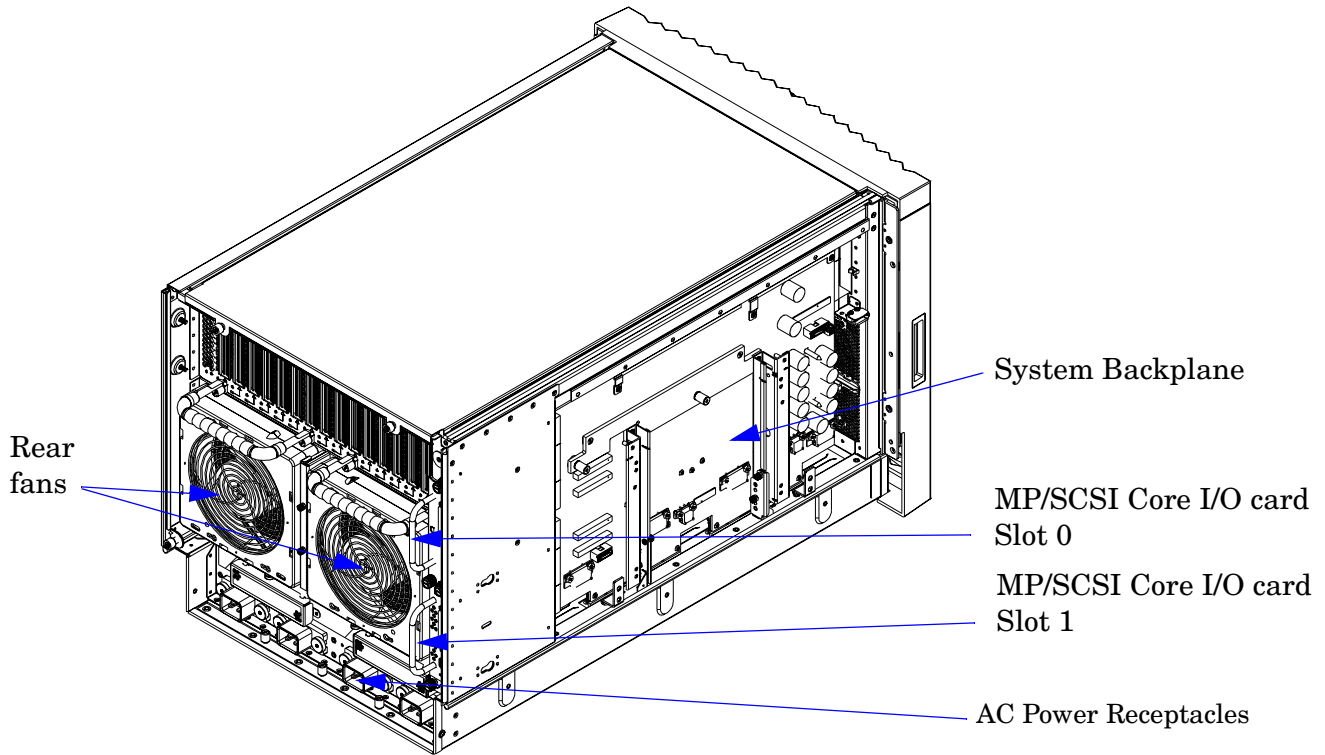

Figure 1-3 Left-Rear View of HP 9000 rp7420 Server



See Figure 1-3 for component locations described below.

When facing the front of the server, access the system backplane by removing the left side cover (cover removed in figure and shown here from the rear). The system backplane hinges from the lower edge and is anchored at the top with a large blue, single jackscrew assembly.

The SCSI ribbon cable assembly (not shown in figure) is connected on the opposite side of the cell board connectors of the system backplane, towards the rear of the server near the core I/O boards.

The two redundant MP/SCSI Core I/O cards are positioned vertically, one above the other, at the rear of the chassis.

Redundant power line cords attach to the AC power receptacles at the bottom rear. Two 20-amp cords are required to power the HP 9000 rp7420 server. Two additional 20-amp cords provide redundancy.

Front Panel

Front Panel Indicators and Controls

The front panel, located on the front of the server, includes the power switch and status LEDs. See Figure 1-4.

Status LEDs

The following status LEDs are on the front panel:

- Standby Power LED (green)
- MP (Management Processor) Present LED (green)
- Status LEDs: Run (green), Fault (red), Attention (yellow), and Power (green) LEDs
- Remote port status LED (green)

Figure 1-4 Front Panel Display

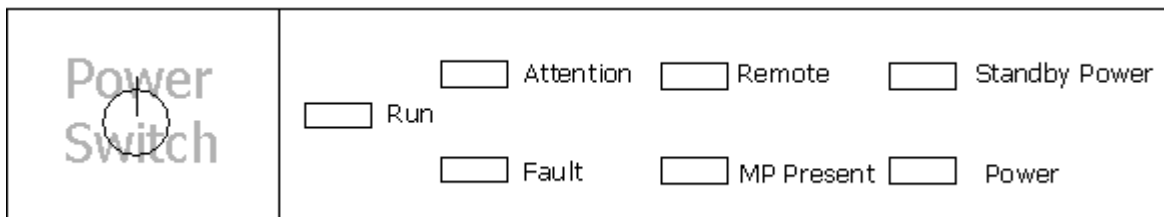

Cell Board

The cell board contains the processors, main memory, and the cell controller (CC) application-specific integrated circuit (ASIC) that interfaces the processors and memory to the I/O. The CC provides a connection that allows communication with the other cell board in the system. It connects to the processor dependent hardware (PDH) and micro controller hardware. Each cell board holds up to 16 DIMMs. There can be one or two cell boards installed in an HP 9000 rp7420 server. A cell board can be selectively powered down for cell replacement without affecting the other cell in another configured partition.

System Backplane

The system backplane is comprised of the clock generation logic, the reset generation logic, DC-to-DC converters, power monitor logic, and two Local Bus Adapter (LBA) ASICs that create internal PCI buses for communicating with the MP (Management Processor)/SCSI Core I/O cards. It also includes connectors for attaching the cell boards, the PCI-X backplane, MP/SCSI Core I/O cards, SCSI cables, bulk power, chassis fans, the front panel display, intrusion switches, and the system scan card. Unlike Superdome or the HP 9000 rp8400, there are no Crossbar Chips (XBC) on the system backplane.

Only half of the core I/O board set connects to the system backplane. The MP/SCSI Core I/O boards plug into the backplane, while the LAN/SCSI boards plug into the PCI-X backplane.

I/O Subsystem

All of the I/O is integrated into the system by way of the PCI-X buses. The CC on each cell board communicates with one system bus adapter (SBA). The SBA converts the SBA link protocol into “ropes”. A rope is defined as a high-speed, point-to-point data bus. The SBA can support up to 16 of these high-speed bi-directional links for a total aggregate bandwidth of approximately 4GB/s. The server supports a maximum of two SBAs.

There are LBA chips on the PCI-X backplane that act as a bus bridge, supporting either one or two ropes and capable of driving 33MHz or 66MHz for PCI cards. The LBAs can also drive at 66MHz or 133MHz for PCI-X cards.

The PCI-X backplane is physically one board but behaves as two independent partitions. SBA 0, its associated LBAs and eight PCI-X slots form I/O Partition 0. SBA 1, its associated LBAs and eight PCI-X slots form I/O Partition 1. One I/O partition may be powered down separate from the other I/O partition.

Table 1-1 PCI-X Slot Types

I/O Partition	Slot	Device ^a
0	8	PCI (33 or 66 MHz) / PCI-X (66 or 133 MHz) 64-bit, 3.3V connector, Hot Plug Slot
0	7	PCI (33 or 66 MHz) / PCI-X (66 or 133 MHz) 64-bit, 3.3V connector, Hot Plug Slot
0	6	PCI (33 or 66 MHz) / PCI-X (66 or 133 MHz) 64-bit, 3.3V connector, Hot Plug Slot
0	5	PCI (33 or 66 MHz) / PCI-X (66 or 133 MHz) 64-bit, 3.3V connector, Hot Plug Slot
0	4	PCI (33 or 66 MHz) / PCI-X (66 or 133 MHz) 64-bit, 3.3V connector, Hot Plug Slot
0	3	PCI (33 or 66 MHz) / PCI-X (66 or 133 MHz) 64-bit, 3.3V connector, Hot Plug Slot
0	2	PCI (33 or 66 MHz) / PCI-X (66 or 133 MHz) 64-bit, 3.3V connector, Hot Plug Slot
0	1 ^b	PCI (33 or 66 MHz) / PCI-X (66 or 133 MHz) 64-bit, 3.3V connector, Hot Plug Slot
1	8 ^c	PCI (33 or 66 MHz) / PCI-X (66 or 133 MHz) 64-bit, 3.3V connector, Hot Plug Slot
1	7	PCI (33 or 66 MHz) / PCI-X (66 or 133 MHz) 64-bit, 3.3V connector, Hot Plug Slot
1	6	PCI (33 or 66 MHz) / PCI-X (66 or 133 MHz) 64-bit, 3.3V connector, Hot Plug Slot
1	5	PCI (33 or 66 MHz) / PCI-X (66 or 133 MHz) 64-bit, 3.3V connector, Hot Plug Slot
1	4	PCI (33 or 66 MHz) / PCI-X (66 or 133 MHz) 64-bit, 3.3V connector, Hot Plug Slot
1	3	PCI (33 or 66 MHz) / PCI-X (66 or 133 MHz) 64-bit, 3.3V connector, Hot Plug Slot
1	2	PCI (33 or 66 MHz) / PCI-X (66 or 133 MHz) 64-bit, 3.3V connector, Hot Plug Slot
1	1	PCI (33 or 66 MHz) / PCI-X (66 or 133 MHz) 64-bit, 3.3V connector, Hot Plug Slot

- a. If the slot is used as a PCI slot then either the 33 MHz or 66 MHz PCI frequency is supported. If the slot is used as a PCI-X slot then either the 66 MHz or 133 MHz PCI-X frequency is supported.
- b. Slot 1 in Partition 0 supports secondary LAN/SCSI card of core I/O set.
- c. Slot 8 in Partition 1 supports primary LAN/SCSI card of core I/O set.

MP/SCSI Core I/O Board

The HP 9000 rp7420 Server accommodates two sets of core I/O functionality. Each core I/O board set consists of a MP/SCSI Core I/O board and a Procurium LAN/SCSI board. At least one MP/SCSI Core I/O board inserted in slot 1 is required (independent of partitions). An additional MP/SCSI Core I/O board can be added in slot 0 as well (and is required in a dual partition system). Both MP/SCSI Core I/O boards are oriented vertically and plug into the system backplane from the rear of the server. See Figure 1-3 on page 6. The MP/SCSI Core I/O board incorporates a dual channel Ultra160 SCSI controller.

Procurium LAN/SCSI Board

At least one Procurium LAN/SCSI board is required for the minimum system configuration; two are required in a dual partition system. The Procurium board is a standard PCI form factor card with PCI card edge connectors. The PCI-X backplane has slot 8 in partition 1 reserved for the required, primary Procurium board and slot 1 in partition 0 supports either a 2nd Procurium board or any other supported add-in PCI-X card. The Procurium board is hot-pluggable.

Internal Disk Devices for the HP 9000 rp7420 Server

In an HP 9000 rp7420 Server, the top internal disk drives connect to cell 1 through the core I/O for cell 1. Both of the bottom disk drives connect to cell 0 through the core I/O for cell 0.

The CD/DVD/DAT drive connects to cell 1 through the core I/O card for cell 1.

NOTE If only one cell board is installed in the server, it must be installed into cell board slot 1 (bottom slot) of the server chassis. See Figure 1-2 on page 5.

Figure 1-5 Internal Disks

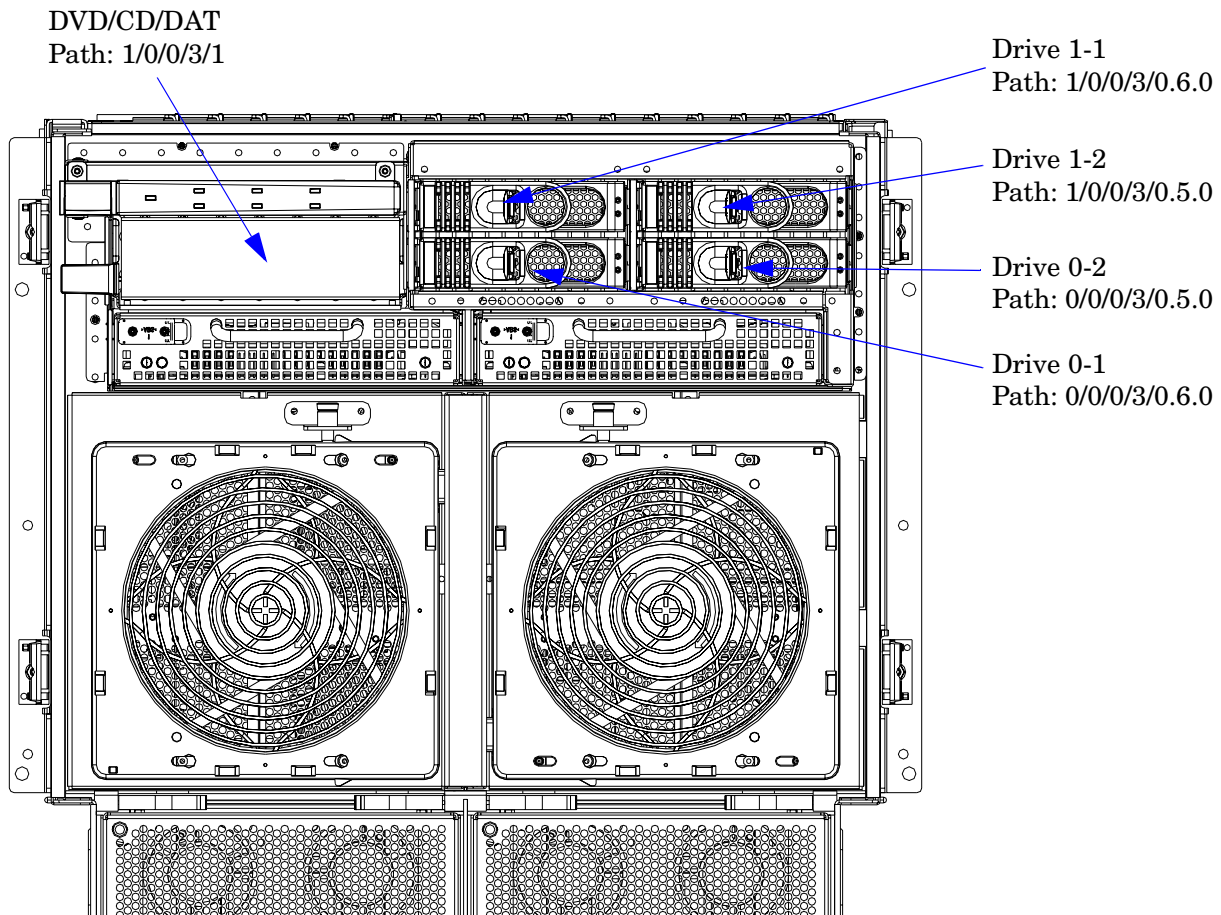

Mass Storage (Disk) Backplane

Internal mass storage connections (to disks) are routed on the mass storage backplane, having connectors and termination circuitry. All disks are hot-pluggable. The HP 9000 rp7420 Server accommodates one internal, removable media device. Therefore, only one power connector for a removable media device is required on the mass storage backplane. The mass storage backplane incorporates a circuit that allows power to the internal removable media device to be programmatically cycled.

2 Unpacking the Server

Inspect shipping containers when the equipment arrives at the site. Check equipment after the packing has been removed. This chapter discusses how to inspect and receive the HP 9000 rp7420 server.

Inspecting the Server Cabinet

- NOTE** The server will ship in one of three different configurations. The configurations are:
- on a pallet installed in a server cabinet
 - on a pallet for rack mount into an existing cabinet on the customer site
 - on a pallet with a wheel kit for installation as a stand-alone server
-

HP shipping containers are designed to protect their contents under normal shipping conditions. After the equipment arrives at the customer site, carefully inspect each carton for signs of shipping damage. A tilt indicator is installed on each carton shipped. The beads in the indicator will roll to the upper position if the container has been tilted to an angle that could cause equipment damage. The tilt indicator itself will have two windows, and each window, under normal conditions, shows four beads present. If a carton has been mishandled, accidentally dropped or knocked against something, the tilt indicator will indicate missing beads. If damage is found, document the damage with photographs and contact the transport carrier immediately.

Examine the server cabinet for visible shipping damage. After unpacking the cabinet, check for damage that might have been obscured by the shipping container. If damage is found after visual inspection, document the damage with photographs and contact the transport carrier immediately.

If the equipment has any damage, a damage claim form must be obtained by the customer from the shipping representative. The customer should complete the form and return it to the shipping representative.

-
- NOTE** The factory provides an installation warranty that is effective from the time the customer receives the shipment until Field Services turns the system over to the customer.
- Upon inspection of a received system and during installation of the system, if any parts or accessories are missing or defective, they will be replaced directly from the factory by a priority process. To request replacement parts, the HP Installation Specialist must contact the local Order Fulfillment group which will coordinate the replacement with the factory.
-

Receiving the Server Cabinet

This section contains information about unpacking the cabinet.

WARNING **Wear protective glasses while cutting the plastic bands around the shipping container. These bands are under tension. When cut, they can spring back and cause serious eye injury.**

NOTE **Position the pallet to allow for enough space to roll the cabinet off the pallet before unpacking.**

Remove the cabinet using the following procedure:

- Step 1.** Cut the polystrap bands around the shipping container.
- Step 2.** Lift the cardboard top cap from the shipping box. See Figure 2-1.

Figure 2-1 Removing the Polystraps and Cardboard

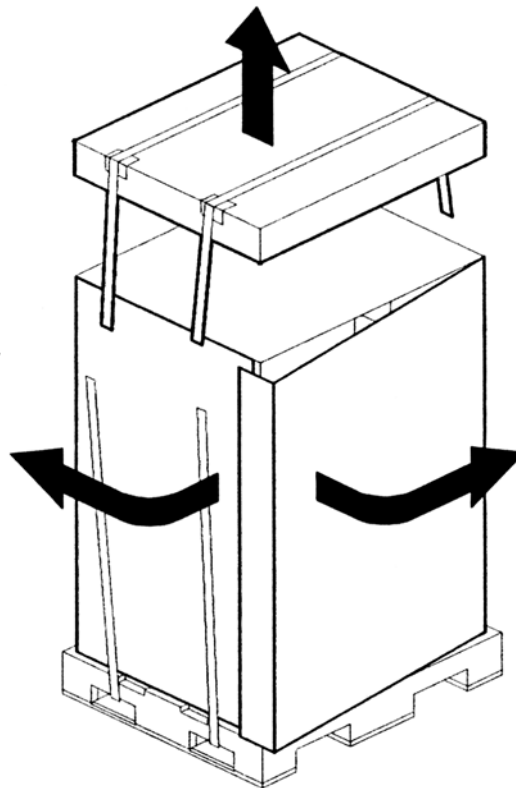

- Step 3.** Remove the cardboard wrap from the pallet.

Step 4. Remove the packing materials.

CAUTION To reduce any ESD exposure, cut off the plastic wrapping around the cabinet. DO NOT pull it off the cabinet.

Step 5. Remove the bolts that hold the ramps to the pallet, and remove the ramps. See Figure 2-2.

NOTE Figure 2-2 shows one ramp attached to the pallet on either side of the cabinet with each ramp secured to the pallet using two bolts. There is another configuration where the ramps are secured together on one side of the cabinet with one bolt.

Figure 2-2 Removing the Shipping Bolts and Plastic Cover

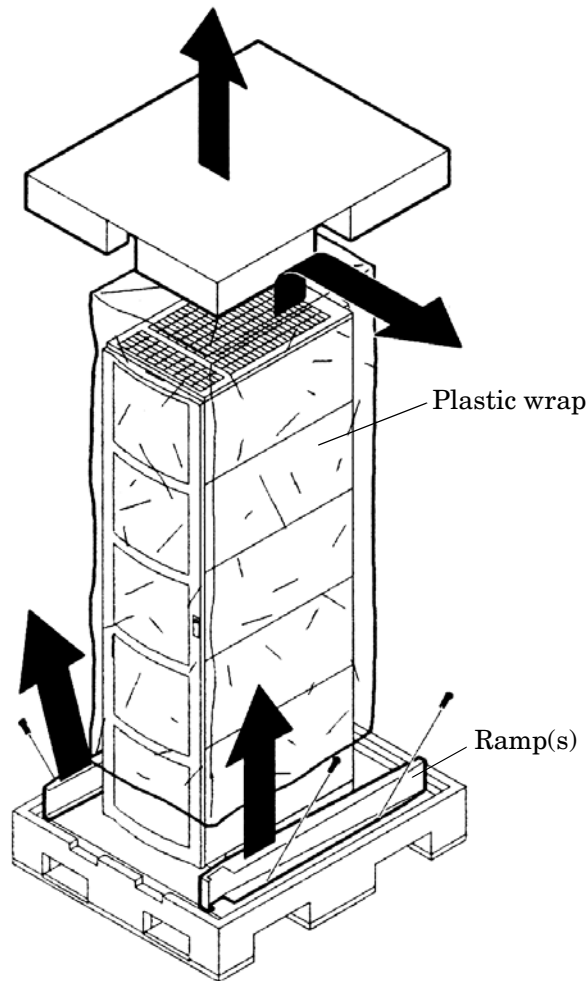

Step 6. Remove the six bolts from the base attaching the rack to the pallet. See Figure 2-3

Figure 2-3 Preparing to Roll Off the Pallet

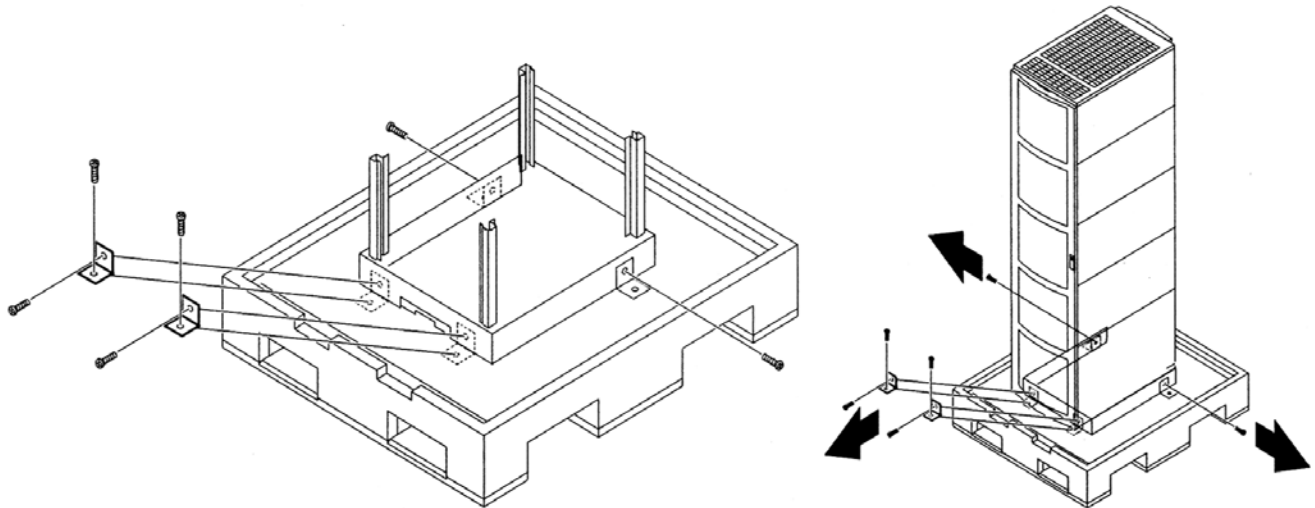

WARNING Use caution when rolling the cabinet off the ramp. A single 2-cell server in the cabinet weighs approximately 220 lb. To avoid a safety hazard, be sure the leveling feet on the cabinet are raised before you roll the cabinet down the ramp, and any time you roll the cabinet on the casters. It is strongly recommended that two people control rolling the cabinet off the pallet.

Step 7. Attach the ramps to the pallet.

Step 8. Carefully roll the cabinet down the ramps.

Step 9. Position cabinet in final location.

Step 10. Remove pallet, ramps and any other packing material from work area.

Securing the Cabinet

When in position, secure and stabilize the cabinet, using the leveling feet at the corners of the base. Follow the instructions in rack documentation to install the anti-tip mechanisms on the bottom front and rear of the rack.

Figure 2-4 **Securing the Cabinet**

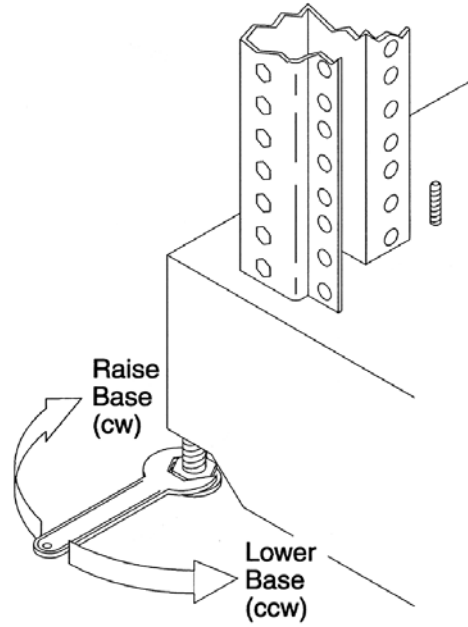

Stand Alone and To Be Racked Systems

The following instructions explain how to configure *stand-alone* or *to be racked* systems.

Rack Mount System Installation

There are several documents written to help with rack mounting the server. This list is intended to guide the HP Installation Specialist to the documentation that has been written by the Rack Solutions team. The external website is <http://h18004.www1.hp.com/products/servers/proliantstorage/bcs-rackandpower/index.html>.

Rack System/E

Detailed rack information for the rack system/E covers the following topics:

- Safety and Regulatory Information
- Description of the Standard Racks and Physical Specifications
- Installation Guidelines
- Procedures

Rack System/E Stabilizer Feet

The stabilizer installation guide for the rack system/E covers the following topics:

- How to Install the Stabilizers
- Moving the Rack

HP J1530B Rack Integration Kit

The rack integration kit information covers installing the following products:

- Ballast Kit (J1479A)
- Anti-Tip Stabilizer Kit (A5540A)
- Slide Rails
- Cable Management Arm (CMA)
- Interlock Device Assembly

This installation guide provides a complete parts list of the hardware and tools required to perform the installation of the products mentioned. Installation of the products is illustrated in this guide. The part number for this installation guide is J1530-90001.

Manual Lifting

Use this procedure only if a HP approved lift is not available.

This procedure should only be performed by two qualified HP Service Personnel utilizing proper lifting techniques and procedures.

System damage can occur through improper removal and re-installation of devices. This task must be performed by trained personnel only. Instructions for removing and re-installing components can be found in the Removal and Replacement chapter of the *HP Service Guide: rp7405/rp7410*.

CAUTION Observe all ESD safety precautions before attempting this procedure. Failure to follow ESD safety precautions could result in damage to the server.

- Step 1.** Follow the instructions on the outside of the server packaging to remove the banding and cardboard top from the server pallet.
- Step 2.** Remove both server side covers and if present, the front bezel.
- Step 3.** Reduce the weight by removing all bulk power supplies and cell boards. Place each on an ESD approved surface.
- Step 4.** Locate server lift handle panels.
- Assembly, Lift Handle, Left Panel - PN: A6752-04045
 - Assembly, Lift Handle, Right Panel - PN: A6752-04048
- Step 5.** Orient lift handle panels as shown in Figure 2-5 on page 19 and Figure 2-6 on page 20 so lift handles hang down flush against panel while installing. Handles lock into a horizontal lift position for lifting.

Step 6. Insert the pins of the panel into the rear of the front rack mount flange of the chassis. See Figure 2-5. (Cell boards are shown installed in figure.)

Figure 2-5 Positioning the Lift handles

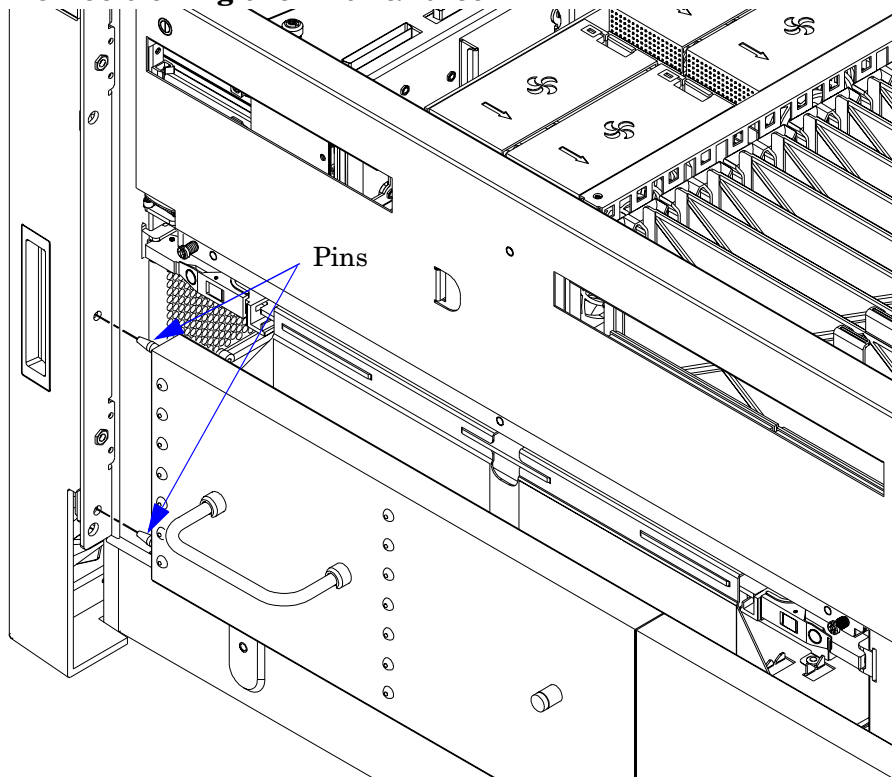

- Step 7.** Pull the spring plunger out and move the handles apart. Install the shoulder washer end of the panel into the keyways at the rear of the server chassis. See Figure 2-6. (Cell boards shown installed in figure.)

Figure 2-6 Inserting the Shoulder Washer Pins Into the Server Chassis

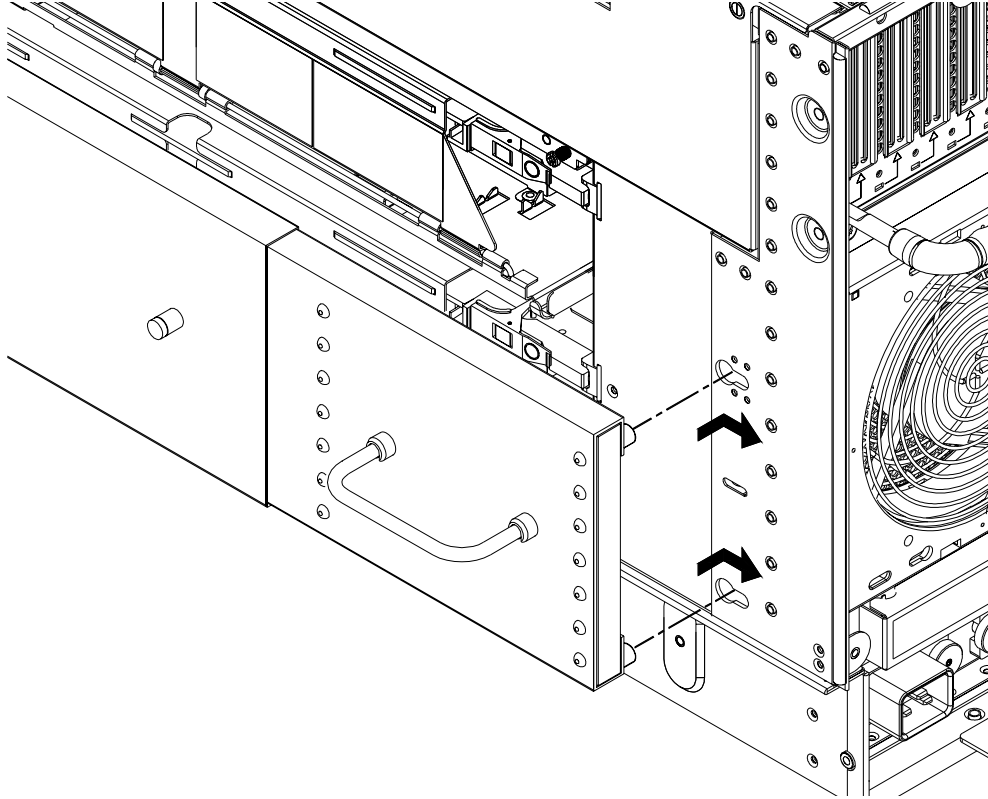

- Step 8.** Continue to pull the handles apart until the spring plunger snaps into the locked position. The spring plunger will drop down into the recess position.

Step 9. Ensure that the handles are secure by pressing the handles together and moving back and forth.

Figure 2-7 Lift Handles Mounted

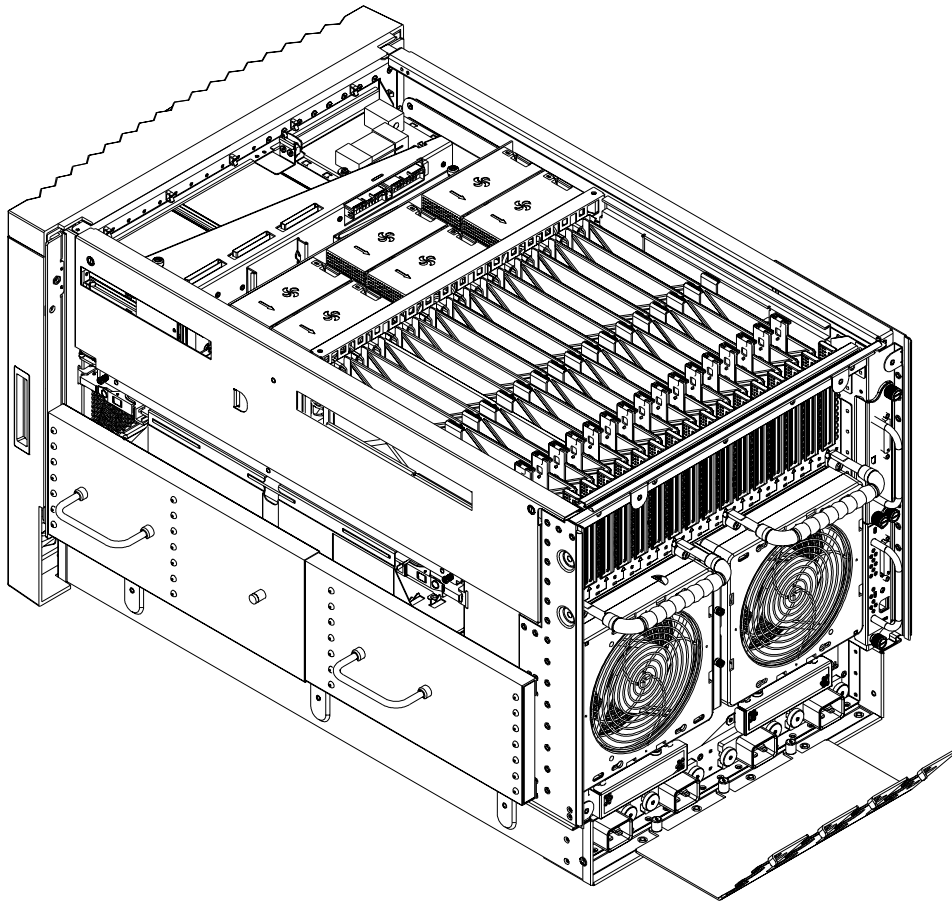

Step 10. Repeat steps 4 through 9 to install handle panel on the opposite side of server.

Step 11. To lift the server, two individuals may rotate the handles 90 degrees to the horizontal position and grasp.

NOTE To ensure proper installation, refer to the “*Installation Guide*” of the HP J1530B Rack Integration Kit.

Step 12. After moving the server, remove the lift handle panels from the chassis.

Step 13. After the server is secured, re-install the previously removed cell boards and bulk power supplies.

Step 14. Reinstall the side covers and front bezel.

Using the RonI Model 17000 SP 400 Lifting Device

A lifter designed by the RonI company is available to rack-mount the server. The lifter can raise 400 lb. to a height of five feet. The lifter can be broken down into several components. When completely broken down, no single component weighs more than 25 lb. The ability to break the lifter down makes it easy to transport from the office to the car and then to the customer site.

Documentation for the RonI lifter has been written by RonI and is on the HP intranet at the Cybrary Web site. Complete details on how to assemble the lifter, troubleshoot the lifter, and maintain the lifter are provided by RonI in the documentation.

Use the following procedure to unload the server from the pallet after the lifter is assembled.

WARNING Use caution when using the lifter. A 2-cell server weighs approximately 220lbs. and it must be centered on the lifter forks before raising it off the pallet to avoid injury.

The first server must be racked in the bottom of a cabinet for safety reasons. Never extend more than one server from the same cabinet while installing or servicing either an HP 9000 rp7405/rp7410 or another server product. Failure to follow these instructions could result in the cabinet tipping over.

Figure 2-8 **RONI Lifter**

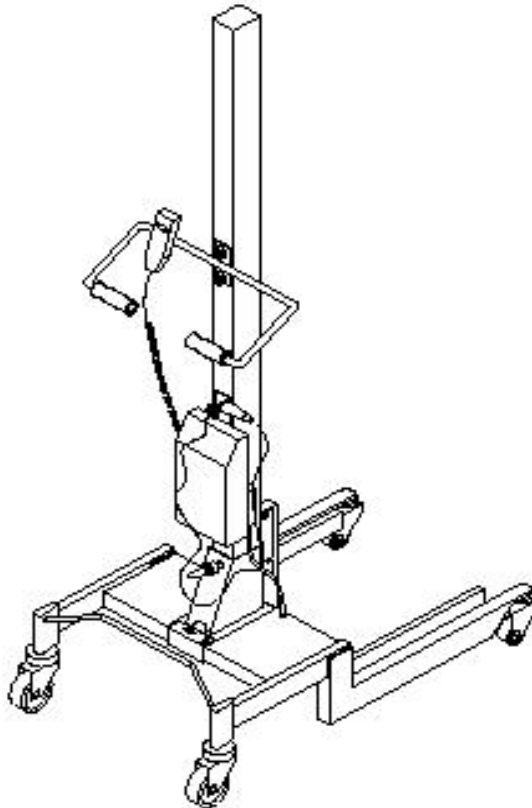

Step 1. Obtain the *HP J1530B Rack Integration Kit Installation Guide* before proceeding with the rack-mount procedure. This guide covers these important steps:

- Installing the anti-tip stabilizer kit (A5540A)
- Installing the ballast kit (J1479A)
- Installing the barrel nuts on the front and rear columns
- Installing the slides

Step 2. Follow the instructions on the outside of the server packaging to remove the banding and cardboard top from the server pallet.

Figure 2-9 Server with Shipping Box Removed

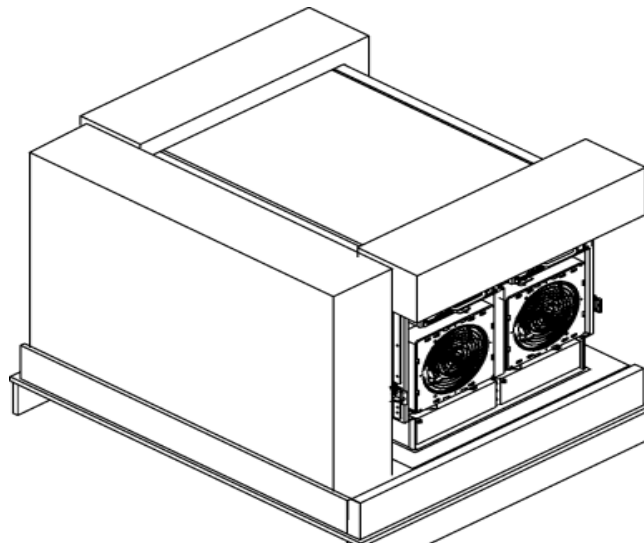

Step 3. Remove all cartons from the pallet, leaving only the server.

Step 4. Remove the two foam cushions for lift access as shown in Figure 2-10.

Figure 2-10 Remove Cushions for Lift Access

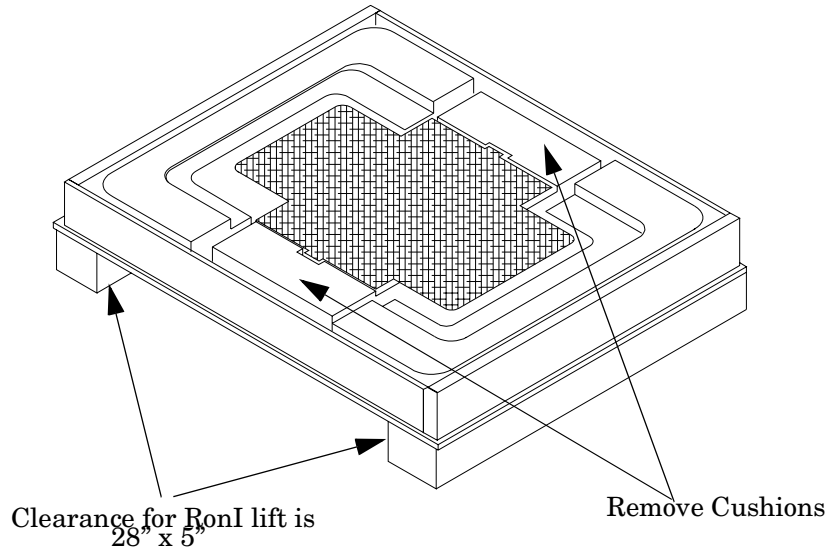

Step 5. Carefully position the lifter forks under the server until lift is against side of server.

Step 6. Slowly raise the server off the pallet until it clears the pallet cushions.

WARNING Do not raise server higher than necessary when moving.

Figure 2-11 Raising a Server Off the Pallet

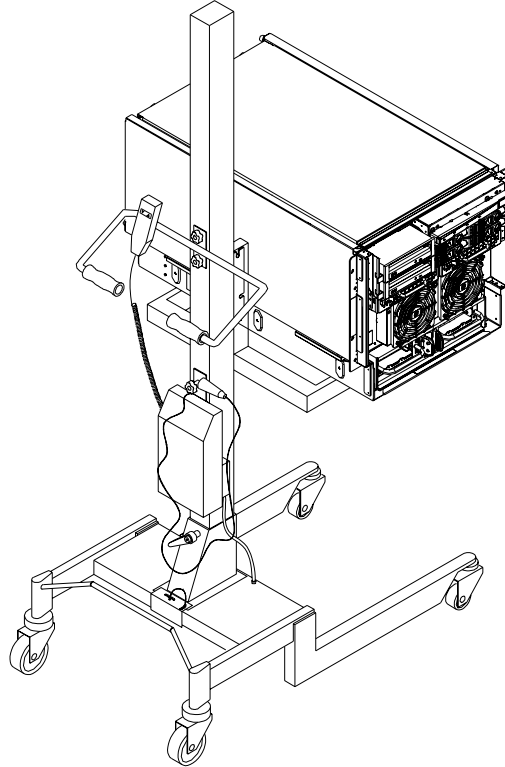

Step 7. Roll the lifter and server away from the pallet.

Step 8. Follow the *HP J1530B Rack Integration Installation Guide* to complete these steps:

- Mounting the server to the slides.
- Installing the CMA (Cable Management Arm)
- Installing the interlock device assembly (if two servers are in the same cabinet)

Wheel Kit Installation

Compare the packing list with the contents of the wheel kit before beginning the installation.

Table 2-1 Wheel Kit Packing List

Part Number	Description	Quantity
A6753-04013	Wheel Kit consisting of the following components:	1
A6753-04002	Right side caster cover	1
A6753-04003	Left side caster cover	1
A6753-04004	Top cover	1
A6753-00007	Caster cover	2
A6753-04001	Right front caster assembly	1
A6753-04005	Right rear caster assembly	1
A6753-04006	Left front caster assembly	1
A6753-04007	Left rear caster assembly	1
0515-2478	M4 x 0.7 8mm T15 steel zinc machine screw (used to attach each caster to the chassis)	4
A6093-44013	Plywood unloading ramp	1
Not Applicable	Phillips head wood screw (used to attach the ramp to the pallet)	2

Tools Required for Installation

The following list provides the installer with the recommended tools to perform the wheel kit installation.

- Diagonal side cutters
- Safety glasses
- Torx screwdriver with T-15, T-25 bits
- Phillips head screwdriver

WARNING **Wear protective glasses while cutting the plastic bands around the shipping container. These bands are under tension. When cut, they can spring back and cause serious eye injury.**

- Step 1.** Cut and remove the polystrap bands securing the server to the pallet.
- Step 2.** Lift the cardboard top from the cardboard tray resting on the pallet.
- Step 3.** Remove the bezel kit carton and the top cushions from the pallet.

Figure 2-12Component Locations

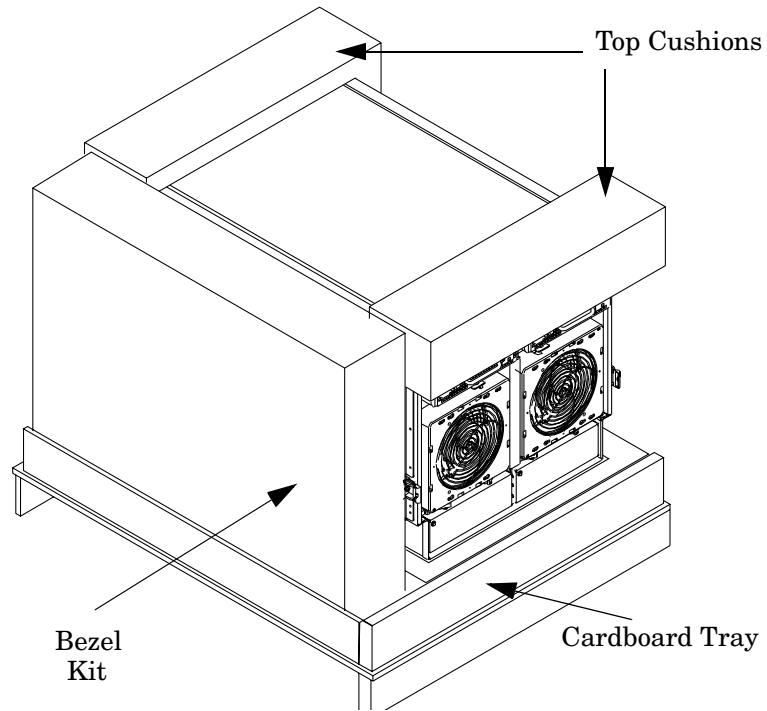

- Step 4.** Unfold bottom cardboard tray.

Step 5. Carefully tilt the server and place one of the foam blocks (A6093-44002) under the left side of the server. Do not remove any other cushions until instructed to do so.

Figure 2-13Left Foam Block Position

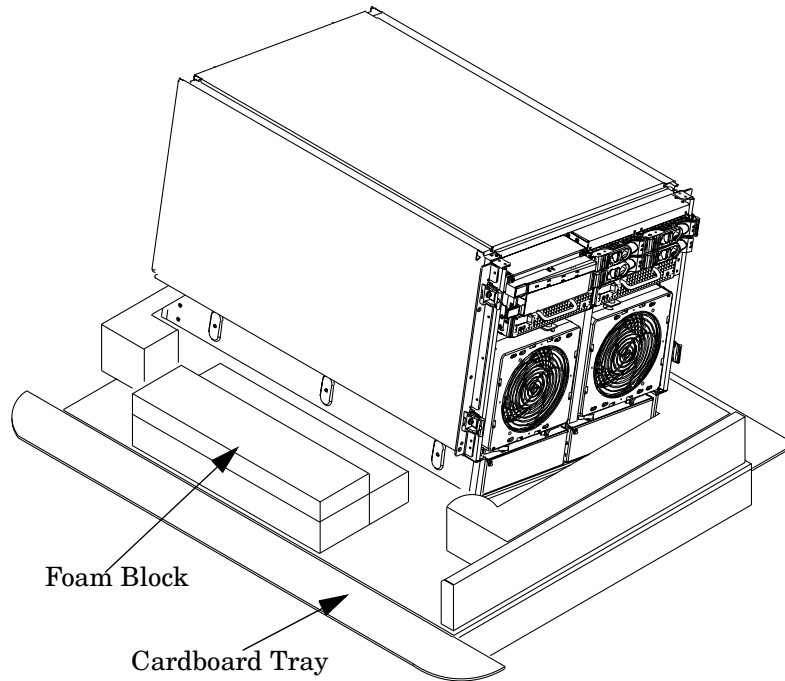

Step 6. Carefully tilt the server and place the other foam block provided in the kit under the right side of the server.

Figure 2-14Right Foam Block Position

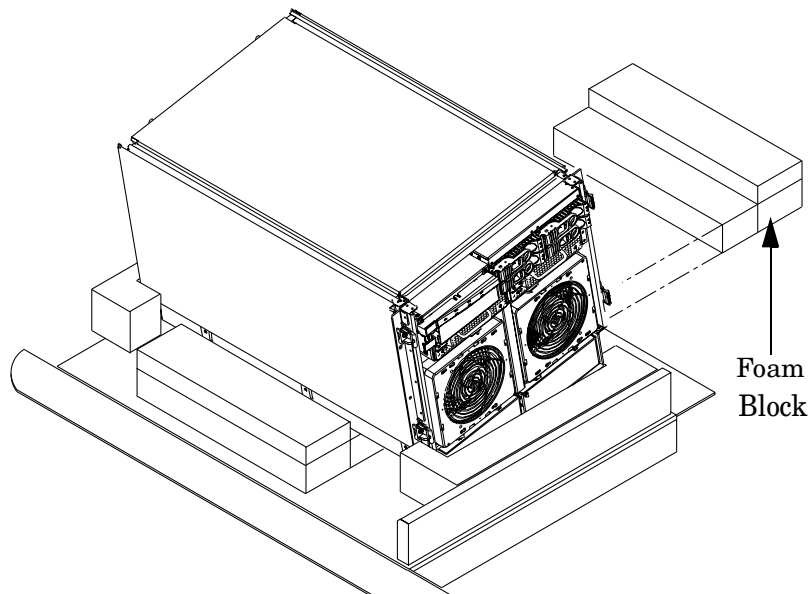

Step 7. Remove the cushions from the lower front and rear of the server. Do not disturb the side cushions.

Figure 2-15 Foam Block Removal

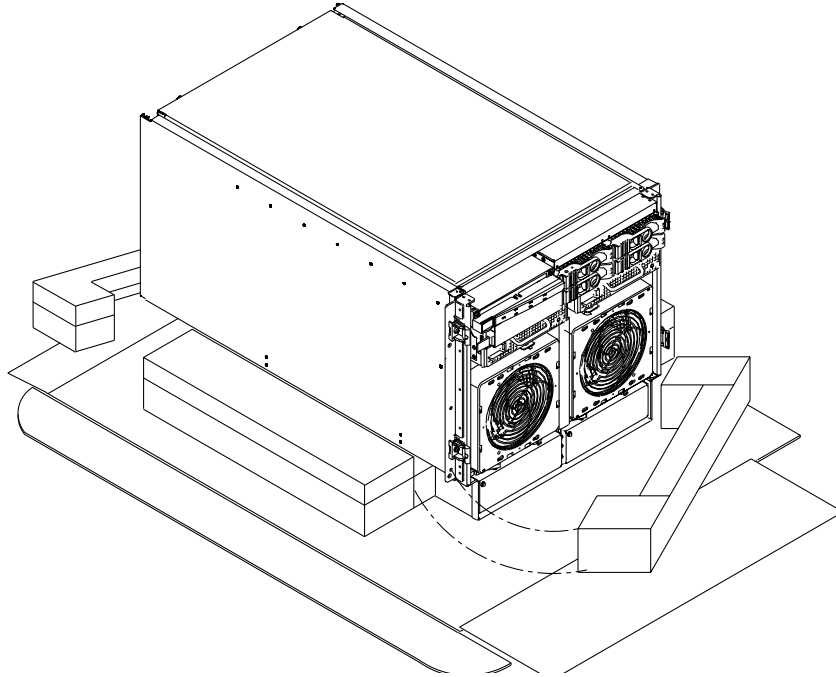

Step 8. Locate and identify the caster assemblies. Use the following table to identify the casters.

NOTE The caster part number is stamped on the caster mounting plate.

Table 2-2 Caster Part Numbers

Caster	Part Number
Right front	A6753-04001
Right rear	A6753-04005
Left front	A6753-04006
Left rear	A6753-04007

Step 9. Locate and remove one of the four screws from the plastic pouch. Attach a front caster to the server.

Figure 2-16 Attaching a Caster to the Server

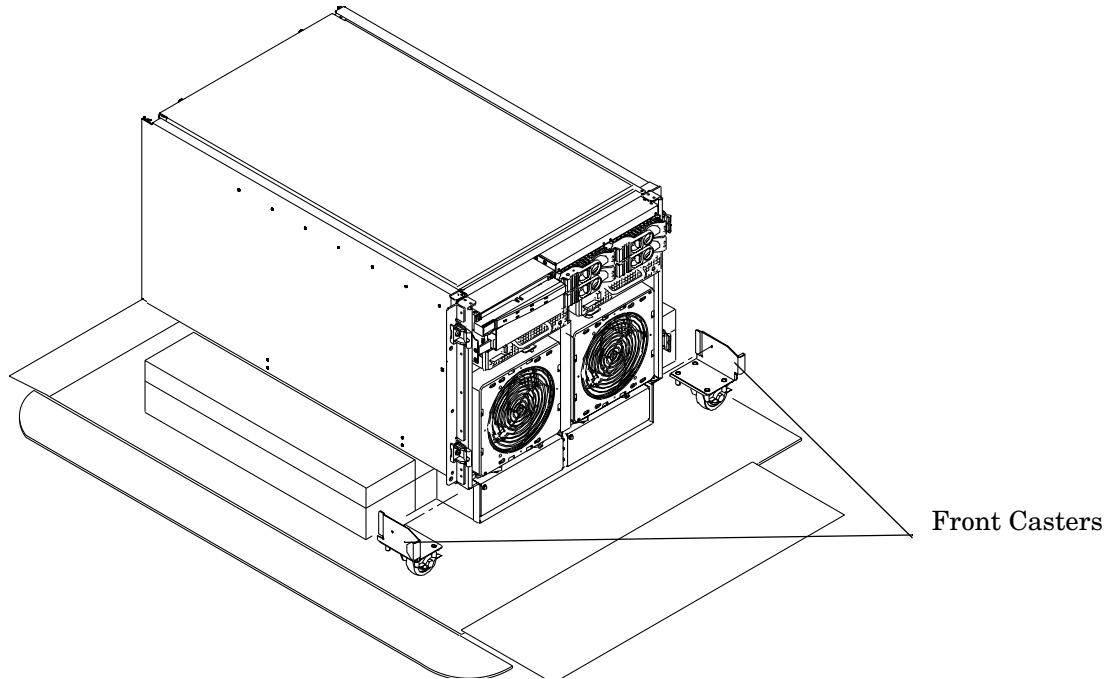

Step 10. Attach the remaining casters to the server using the screws supplied in the plastic pouch.

Step 11. Remove the foam blocks from the left and right side of the server.

Step 12. Locate the plywood ramp.

Step 13. Facing the front of the server, attach the plywood ramp to the edge of the pallet.

NOTE There are two pre-drilled holes in the ramp. Use the two screws taped to the ramp to attach the ramp to the pallet.

Step 14. Carefully roll the server off the pallet and down the ramp.

Step 15. Locate the caster covers.

NOTE The caster covers are designed to fit on either side of the server.

NOTE It may be necessary to loosen or remove the mounted side covers to install the supplied caster covers.

Step 16. Insert the slot on the caster cover into the front caster. Secure the cover to the server by tightening the captive screw on the cover at the rear of the server.

Figure 2-17 Securing Each Caster Cover to the Server

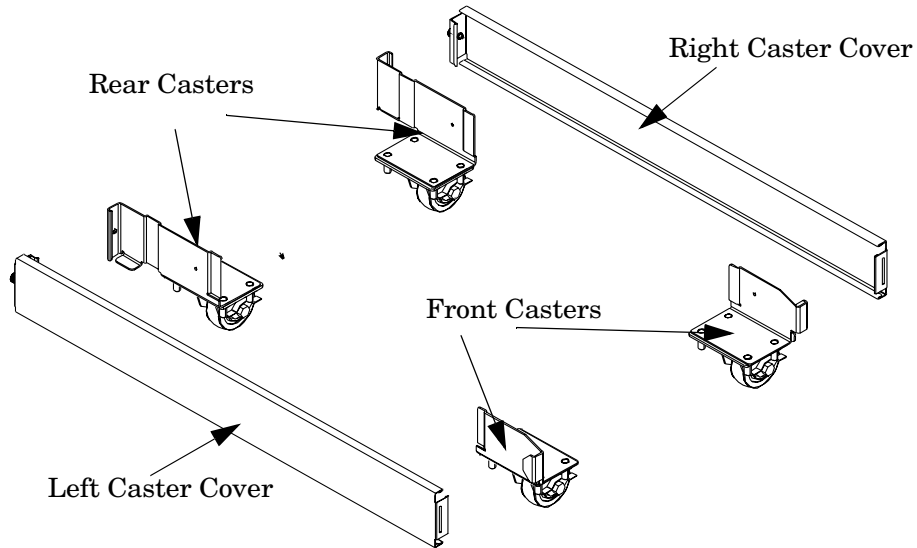

Step 17. Install the front bezel.

- Locate and mount the 4 plastic spring clips on front corners of chassis.
- Orient the bezel onto the front of the server.
- Push the bezel onto the spring clips on either side of the chassis until it snaps in place.

Step 18. Wheel kit installation is complete when both caster covers are attached to the server, all covers are installed and the front bezel is mounted.

Figure 2-18 Completed Server

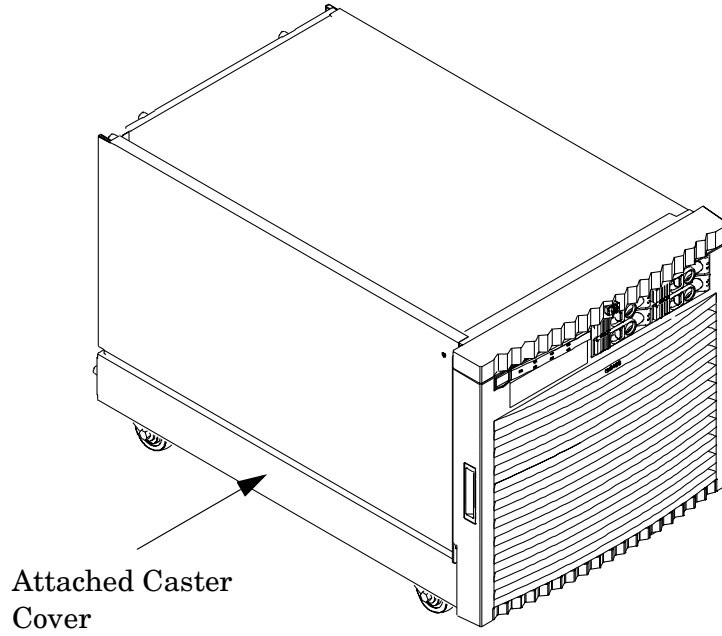

3 Installing Accessories

The following options may be installed in the HP 9000 rp7420 server:

- additional hard disk drive storage
- removable media device storage
- PCI and PCI-X I/O cards

Installing Add-On Products

This section provides information on installation of additional products that may have been ordered after server installation.

Embedded Mass Storage

When hard disks are installed, the top two hard disk drives are controlled by cell 1 through its assigned MP/SCSI Core I/O card. The bottom two hard disk drives are controlled by cell 0 through its assigned MP/SCSI Core I/O card.

The DVD/CD/DAT removable media drive is controlled by cell 1 through its assigned MP/SCSI Core I/O card. See Figure 3-1.

A list of replacement disk drives for the HP 9000 rp7420 server is in Appendix A of the Service Guide for the HP 9000 rp7420 server. The list contains both removable media disk drives and hard disk drives.

Figure 3-1 Internal Disks

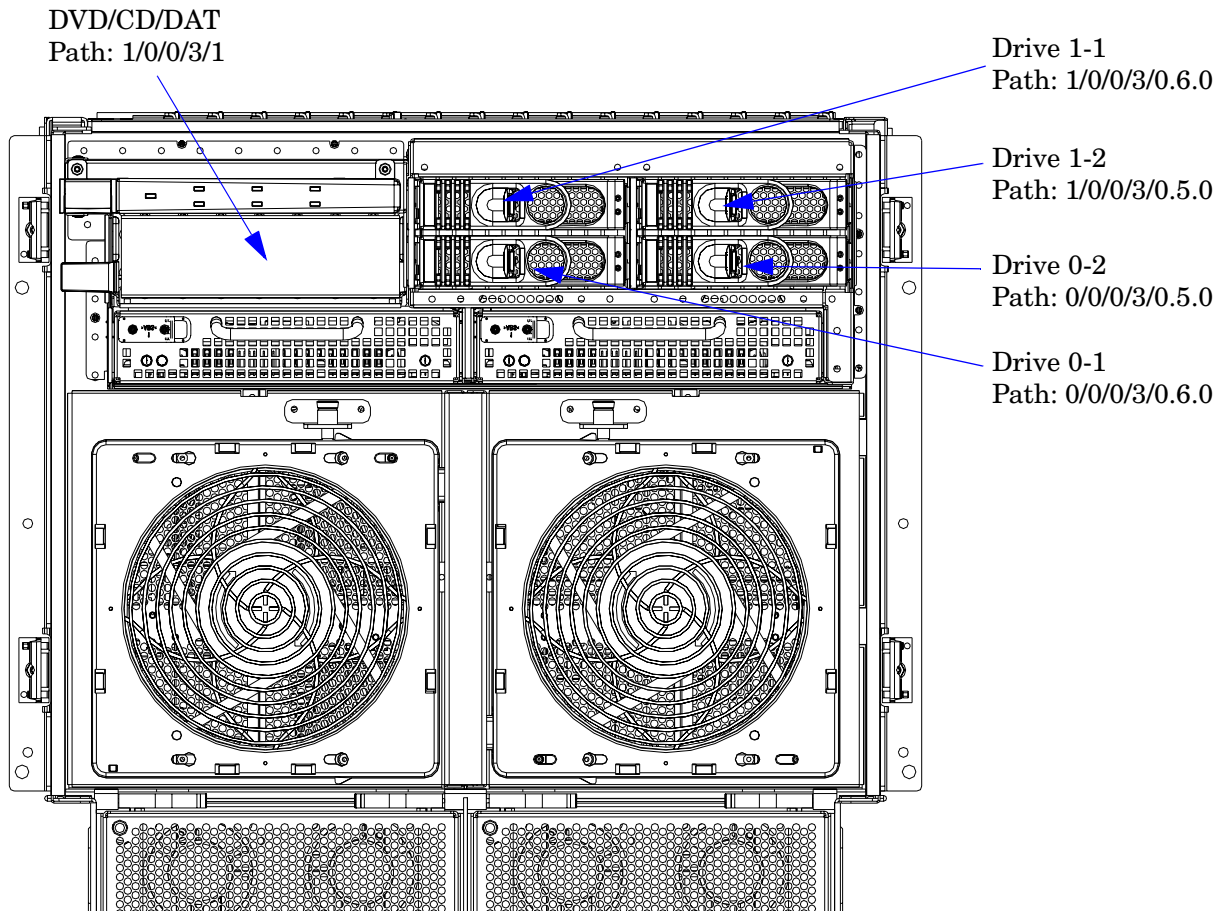

Hard Disk Drive Installation

The disk drives are located in the front of the chassis. The hard disk drives are hot-plug drives.

CAUTION Observe all ESD safety precautions before attempting this procedure. Failure to follow ESD safety precautions could result in damage to the HP 9000 rp7420 server.

- Step 1.** Be sure the front locking latch is open, then position the disk drive in the chassis.
- Step 2.** Slide the disk drive into the chassis; a slow, firm pressure is needed to properly seat the connector.
- Step 3.** Press the front locking latch to secure the disk drive in the chassis.
- Step 4.** If the server OS is running, spin up the disk by entering one of the following commands:

```
#diskinfo -v /dev/rdisk/cxtxdx  
  
#ioscan -f
```

Removable Media Drive Installation

The DVD drive or DDS-4 DAT tape drive is located in the left front of the chassis. The server power must be turned off before installation. Refer to “Shutting Down nPartitions and Powering OFF Hardware Components” in the Service Guide for the HP 9000 rp7420 server for more information.

CAUTION Observe all ESD safety precautions before attempting this procedure. Failure to follow ESD safety precautions could result in damage to the HP 9000 rp7420 server.

- Step 1.** Remove front bezel.
- Step 2.** Remove filler panel from server.
- Step 3.** Install left and right media rails and clips to the drive.
- Step 4.** Connect the cables to the rear of the drive.
- Step 5.** Fold the cables out of the way and slide the drive in the chassis.

The drive easily slides into the chassis; however, a slow firm pressure is needed for proper seating.

The front locking tab will latch to secure the drive in the chassis.

PCI/PCI-X Card Cage Assembly I/O Cards

A number of PCI and PCI-X I/O cards are supported in the HP 9000 rp7420 Server. Known cards supported at the release of this manual are shown in Table 3-1.

Table 3-1 HP 9000 rp7420 Server I/O Cards

Part Number	Card Description	Number of Cards Supported (B - Bootable)
A3739B	FDDI Dual Attach	15
A6847A	Next Generation 1000B-SX	15
A6825A	Next Generation 1000B-T	15
A5149A	Ultra2 SCSI	15B
A5150A	2-port Ultra2 SCSI	15B
A5159B	2-port FWD SCSI	15B
A5230A	10/100B-TX (RJ45)	15
A5483A	ATM 622 (MMF connector)	15
A5506B	4-port 10/100B-TX	15
A5513A	ATM 155 (MMF connector)	15
A5515A	ATM 155 (UTP5 connector)	15
A5783A	Token Ring (4/16/100 Mb/s)	15
A5838A	2-port Ultra2-SCSI + 2-port 100T	15B
A5856A	RAID 4Si	12B
A6386A	Hyperfabric II	8
A6748A	8-port Terminal MUX	15
A6749A	64-port Terminal MUX	15
A6794AX	Procurium GigE LAN/SCSI combo card	2B
A6795A	2G FC Tachlite	15B
A6826A	2-port 2 Gb FC	15B
A6828A	1-port U160 SCSI	15B
A6829A	2-port U160 SCSI	15B
A7011A	1000BaseSX Dual Port	15
A7012A	1000 BaseT Dual Port	15
A7143A	U160 RAID - SmartArray 5304	12B

Table 3-1 HP 9000 rp7420 Server I/O Cards (Continued)

Part Number	Card Description	Number of Cards Supported (B - Bootable)
A7173A	2 port U320 SCSI	15B
J3525A	2-port serial (X25/FR/SDLC)	15
J3526A	4-port serial (X25/FR)	15
Z7340A	8-port ACC	16
A4800A	FWD SCSI	15B
A4926A	Gigabit Ethernet (1000B-SX)	15
A4929A	Gigabit Ethernet (1000B-T)	15
A5158A	Fibre Channel PCI Adapter	15B
A6092A	Hyperfabric (PCI 4X)	4
A9782A	PCI-X 1000Base-T GigE/2Gb Combo	15B
A9784A	PCI-X 1000Base-T GigE/2G FC Combo	15B
A9890A	SmartArray 6402 2-channel RAID	12B
A9891A	SmartArray 6404 4-channel RAID	12B
AB286A	PCI-X 2-Port 4X InfiniBand HCA (HPC)	1
AB287A	10G Ethernet	2
AB290A	U320 SCSI/GigE Combo Card	15B
AB378A	1-port 4Gb FC card PCI-X	15B
AB379A	2-port 4Gb FC card PCI-X	15B
AB465A	PCI-X 2-port 1000B-T/2-port 2Gb FC Combo	15B
AB545A	4-port 1000B-T Ethernet	15
AD278A	8-port Terminal MUX	15
AD279A	64-port Terminal MUX	15

PCI I/O Card Installation

HP 9000 rp7420 Servers implement Manual Release Latch (MRL) hardware for use in online add or replacement (OLAR) operations. If an MRL is left open while the server is booting, HP-UX can incorrectly cache PCI slot power status causing OLAR operations to fail. To prevent this situation, ensure all the MRLs are closed before booting the server.

If OLAR reports that a slot is present and powered off, but no OLAR operations to turn power on to that slot have succeeded even after the MRL is closed, the MRL may have been left open during boot. To clear this condition, close the MRL for the PCI slot then power off the PCI slot using the `rad -o` command. This will allow future OLAR operations to succeed on this PCI slot.

IMPORTANT The installation process varies depending on what method for installing the PCI card is selected. PCI I/O card installation procedures should be downloaded from the <http://docs.hp.com/> Web site. Background information and procedures for adding a new PCI I/O card using online addition are found in the Interface Card OL* Support Guide.

Installing PCI or PCI-X Card(s) in a Powered Down System

- Step 1.** Remove the top cover.
- Step 2.** Locate and select a supported slot.
- Step 3.** Remove the PCI bulkhead filler panel.
- Step 4.** Lever open the Manual Release Latch for selected slot.
- Step 5.** Install the I/O card in the slot.

NOTE A slow, firm pressure is needed to properly seat the card into the backplane.

- Step 6.** Flip the Manual Release Latch for the card slot to the closed position.
- Step 7.** Follow I/O card manufacturer instructions for specific cabling directions.

Prerequisites for Adding a PCI I/O Card Using the Attention Button

The prerequisites for this procedure are:

- Drivers for the card have already been installed.
- There are no drivers associated with the slot.
- The green power LED is steady **OFF**. Should the empty slot be in the **ON** state use the `olrad` command or the `pdweb` tool to power the slot **OFF**.
- The yellow attention LED is steady **OFF** or is blinking if a user has requested the slot location.
- Refer to the host bus adapter (HBA) documentation for details on card installation.
- Run the `olrad -q` command to determine the status of all the PCI I/O slots.
- Obtain a copy of the interface card guide for instructions on preparing the operating system for the online addition of the PCI I/O card before attempting to insert a PCI I/O card into the PCI-X card cage assembly backplane slot.

CAUTION Observe all ESD safety precautions before attempting this procedure. Failure to follow ESD safety precautions could result in damage to the server.

This procedure describes how to perform an **online addition** of a PCI card using the attention button for cards whose drivers support online add or replacement (OLAR). The attention button is also referred to as the doorbell.

- Step 1.** Remove the top cover.
- Step 2.** Remove the PCI bulkhead filler panel.
- Step 3.** Lever open the Manual Retention Latch for selected slot. Refer to Figure 3-2.
- Step 4.** Install the I/O card in the slot.

NOTE A slow, firm pressure is needed to properly seat the card into the backplane.

- Step 5.** Flip the Manual Release Latch for the card slot to the closed position.

CAUTION Working out of sequence or not completing the actions within each step could cause the system to crash.

Do not press the attention button until the latch is locked.

- Step 6.** Press the attention button.
The green power LED will start to blink.

Figure 3-2 PCI I/O Slot Details

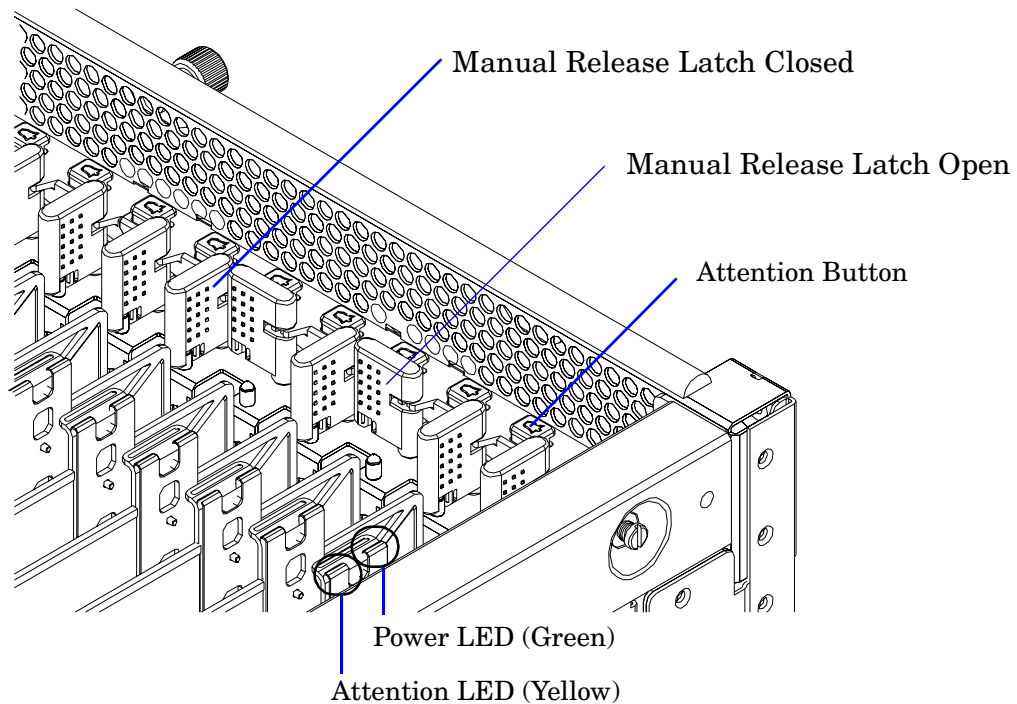

- Step 7.** Wait for the green power LED to stop blinking and remain solid green.
- Step 8.** Check for errors in the hotplug daemon log file (default: /var/adm/hotplugd.log).

The critical resource analysis (CRA) performed while doing an attention button initiated add action is very restrictive and the action will not complete—it will fail—to protect critical resources from being impacted. For finer control over CRA actions use pdweb or the olrad command. Refer to the Interface Card OL* Support Guide located on the Web at <http://docs.hp.com> for details.

Step 9. Replace the top cover.

Step 10. Connect all cables to the installed PCI card.

4 Cabling and Power Up

After the system has been unpacked and moved into position, it must be connected to an AC power source. The AC power must be checked for the proper voltage before the system is powered up. This chapter describes these activities.

Voltage Check

This section provides voltage check information for use on the customer site. The emphasis focuses on measuring the voltages at the power cord plug end specified as an IEC 320 C19 type plug. This end plugs directly into the back of the HP 9000 rp7420 Server chassis.

NOTE These procedures must be performed for each power cord that will be plugged directly into the back of the HP 9000 rp7420 Server. If the expected results from this procedure are not observed during the voltage check, see the next section titled “Voltage Check (Additional Procedure).”

Preface

The HP 9000 rp7420 Server requires a minimum of 2 power cords. To enable full power redundancy, 4 power cords may be used. When using 4 power cords, dual power sources may be used to provide additional power source protection.

Power cords are designated and labeled A0, A1, B0 and B1. Cords A0 & B0 should be energized from the same power source and cords A1 & B1 should be energized from a second, independently qualified power source. The cord labeling corresponds to the labeling at the servers power receptacles.

Voltage Range Verification of Receptacle

This measures the voltage between L1 and L2, L1 to ground, and L2 to ground. Three separate measurements are performed during this procedure. See Figure 4-1 for voltage reference points when performing the following measurements.

Figure 4-1 Voltage Reference Points for IEC 320 C19 Plug

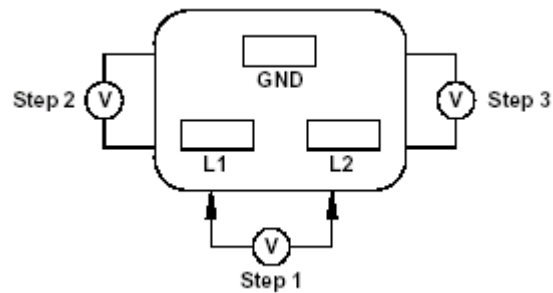

IMPORTANT These measurements must be performed for every power cord that plugs into the HP 9000 rp7420 Server.

- Step 1.** Measure the voltage between L1 and L2. This is considered to be a phase-to-phase measurement in North America. In Europe and certain parts of Asia-Pacific, this measurement is referred to as a phase-to-neutral measurement. The expected voltage measured should be between 200–240 V AC regardless of the geographic region.
- Step 2.** Measure the voltage between L1 and ground. In North America, verify this voltage is between 100–120 V AC. In Europe and certain parts of Asia-Pacific, verify this voltage is between 200–240 V AC.
- Step 3.** Measure the voltage between L2 and ground. In North America, verify this voltage is between 100–120 V AC. In Europe and certain parts of Asia-Pacific, verify this voltage is 0 (zero) V AC.

Table 4-1 provides single phase voltage measurement examples dependent on the geographic region where these measurements are taken.

Table 4-1 Single Phase Voltage Examples

	Japan	North America	Europe ^a
L1-L2	210 V	208 V or 240 V	230 V
L1-GND	105 V	120 V	230 V
L2-GND	105 V	120 V	0 V

a. In some European countries there might not be a polarization.

Safety Ground Verification (Single Power Source)

This procedure measures the voltage level between A0 and A1. The voltage level between B0 and B1 will also be verified. All measurements will be taken between ground pins. See Figure 4-2 for ground reference points when performing these measurements.

Figure 4-2 Safety Ground Reference Check—Single Power Source

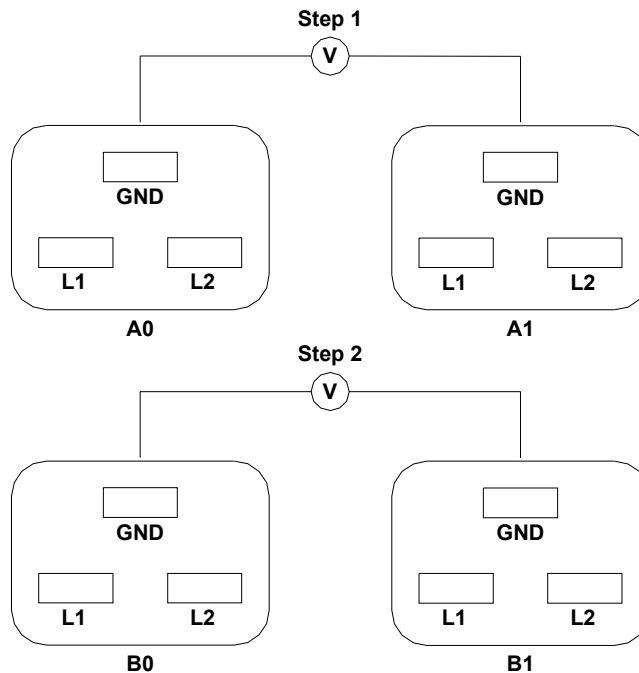

- Step 1.** Measure the voltage between A0 and A1. Take the AC voltage down to the lowest scale on the volt meter. One probe is inserted into the ground pin for A0. The other probe is inserted into the ground pin for A1. Verify that the measurement is between 0-5 VAC. If the measurement is 5 V or greater, escalate the situation. Do not attempt to plug the power cords into the server cabinet.
- Step 2.** Measure the voltage between B0 and B1. Take the AC voltage down to the lowest scale on the volt meter. One probe will be inserted into the ground pin for B0. The other probe will be inserted into the ground pin for B1. Verify that the measurement is between 0-5 VAC. If the measurement is 5 V or greater, escalate the situation. Do not attempt to plug the power cords into the server cabinet.

Safety Ground Verification (Dual Power Source)

This procedure measures the voltage level between A0 and A1, between B0 and B1, between A0 and B0, and between A1 and B1. All measurements will be taken between ground pins. See Figure 4-3 for ground reference points when performing these measurements.

Figure 4-3 Safety Ground Reference Check—Dual Power Source

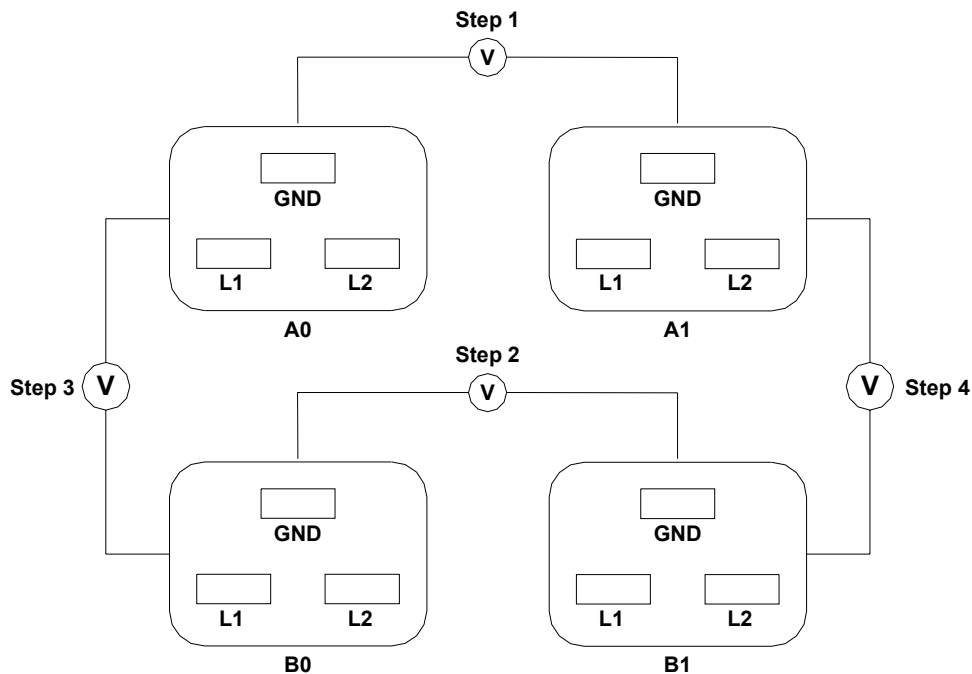

- Step 1.** Measure the voltage between A0 and A1. Take the AC voltage down to the lowest scale on the volt meter. One probe is inserted into the ground pin for A0. The other probe is inserted into the ground pin for A1. Verify that the measurement is between 0–5 VAC. If the measurement is 5 V or greater, escalate the situation. Do not attempt to plug the power cords into the server cabinet.
- Step 2.** Measure the voltage between B0 and B1. Take the AC voltage down to the lowest scale on the volt meter. One probe is inserted into the ground pin for B0. The other probe is inserted into the ground pin for B1. Verify that the measurement is between 0–5 VAC. If the measurement is 5 V or greater, escalate the situation. Do not attempt to plug the power cords into the server cabinet.
- Step 3.** Measure the voltage between A0 and B0. Take the AC voltage down to the lowest scale on the volt meter. One probe is inserted into the ground pin for A0. The other probe is inserted into the ground pin for B0. Verify that the measurement is between 0–5 VAC. If the measurement is 5 V or greater, escalate the situation. Do not attempt to plug the power cords into the server cabinet.
- Step 4.** Measure the voltage between A1 and B1. Take the AC voltage down to the lowest scale on the volt meter. One probe is inserted into the ground pin for A1. The other probe is inserted into the ground pin for B1. Verify that the measurement is between 0–5 VAC. If the measurement is 5 V or greater, escalate the situation. Do not attempt to plug the power cords into the server cabinet.

Voltage Check (Additional Procedure)

The voltage check ensures that all phases (and neutral, for international systems) are connected correctly to the cabinet and that the AC input voltage is within limits.

This procedure must be performed if the previous voltage check procedure did not yield the expected results as previously outlined.

NOTE If a UPS is used, refer to applicable UPS documentation for information to connect the server and to check the UPS output voltage. UPS User Manual documentation is shipped with the UPS. Documentation can also be found at <http://www.hp.com/racksolutions>.

Step 1. Verify that site power is **OFF**.

Step 2. Open the site circuit breakers.

Step 3. Verify that the receptacle ground connector is connected to ground. See Figure 4-4 for connector details.

Step 4. Set the site power circuit breaker to **ON**.

Figure 4-4 Wall Receptacle Pinouts

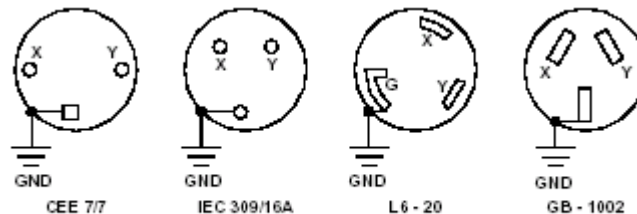

WARNING There is a risk of shock hazard while testing primary power. Use properly insulated probes.

Step 5. Verify that the voltage between receptacle pins X and Y is between 200 and 240 V AC.

Step 6. Set the site power circuit breaker to **OFF**.

Step 7. Ensure that power is removed from the server.

Step 8. Route and connect the server power connector to the site power receptacle.

- For locking type receptacles, line up the key on the plug with the groove in the receptacle.
- Push the plug into the receptacle and rotate to lock the connector in place.

WARNING Do not set site AC circuit breakers serving the processor cabinets to **ON** before verifying that the cabinet has been wired into the site AC power supply correctly. Failure to do so might result in injury to personnel or damage to equipment when AC power is applied to the cabinet.

Step 9. Set the site power circuit breaker to **ON**.

WARNING SHOCK HAZARD
Risk of shock hazard while testing primary power.
Use properly insulated probes.
Be sure to replace access cover when finished testing primary power.

Step 10. Set the server power to **ON**.

Step 11. Check that the indicator light on each power supply is lit.

Connecting AC Input Power

The server can receive AC input power from two different AC power sources. If two separate power sources are available as depicted in Figure 4-6 on page 49, the server can be plugged into the separate power sources, increasing system reliability should one power source fail. The main power source is defined to be A0 and B0. The redundant power source is defined to be A1 and B1. See Figure 4-5 for the AC power input label scheme.

NOTE When running the server with a single power source, either A0 and B0 or A1 and B1 should be used. All other combinations are not supported. Either combination requires two power cords.

Figure 4-5 Power Cord Configuration

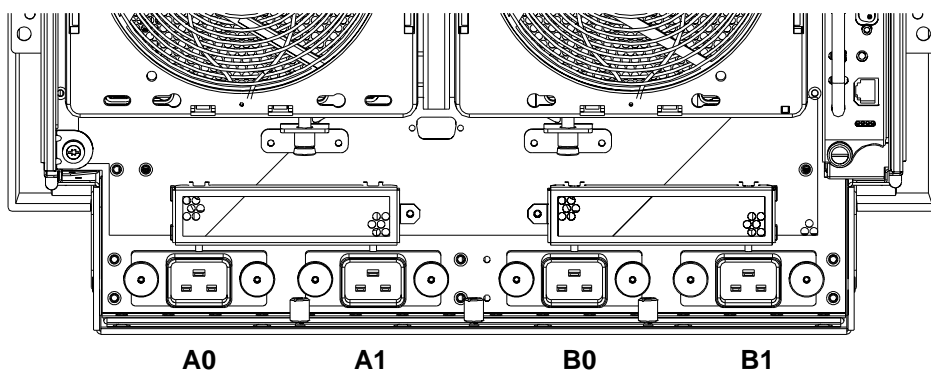

The server has five power cord configurations:

- All four power cords installed (preferred configuration)
- Cords A0 and A1 only
- Cords B0 and B1 only
- Cords A0 and B0 only
- Cords A1 and B1 only

A single-power-cord configuration is not allowed.

The power cord configuration is passed to the operating system using the `pwrgrd` (Power Grid) command. Each of the five selections in the `pwrgrd` command matches one of the configurations. The appropriate option should be selected for the actual line cord configuration. With the correct configuration selected, the LEDs should be green. When the `pwrgrd` command is invoked, the following menu is displayed:

```
prompt> pwrgrd
Power grid configuration preference.
1. Grid A only (Cords A0,B0 required)
2. Grid B only (Cords A1,B1 required)
3. Grids A & B (Cords A0,A1,B0,B1 required)
4. Cords A0 & B0 only
5. Cords A1 & B1 only
```

Select Option:

Figure 4-6 Power Source versus. Power Distribution

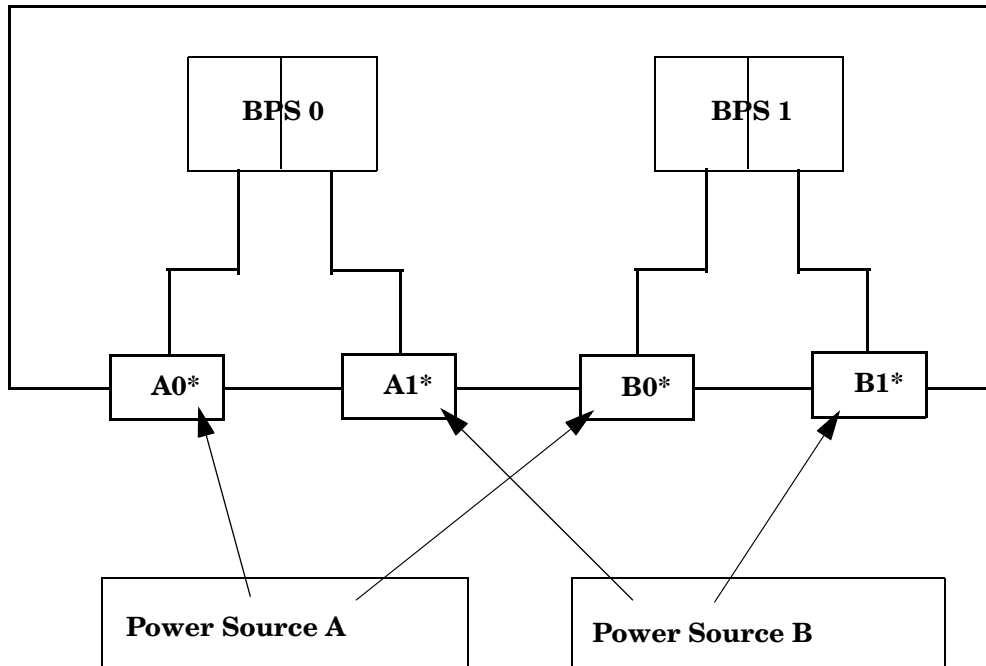

*180-269 VAC

WARNING Voltage is present at various locations within the server whenever a power source is connected. This voltage is present even when the main power switch is in the OFF position. To completely remove power, all power cords must be removed from the server. Failure to observe this warning could result in personal injury or damage to equipment.

NOTE System firmware prevents boot when a single power cord configuration is detected.

MP/SCSI Core I/O Connections

Each HP 9000 rp7420 Server can have up to two core I/O board sets installed, which allows two partitions to operate, or MP/SCSI Core I/O redundancy in a single partition configuration. Each core I/O board set consists of two boards: the MP/SCSI Core I/O board and the LAN/SCSI board. The MP/SCSI Core I/O board is oriented vertically and accessed from the back of the server. The LAN/SCSI is accessed from the PCI/PCI-X expansion card bay. Only the primary core I/O board set (MP/SCSI Core I/O slot 1 and LAN/SCSI slot 8, chassis 1) is required for a single partition implementation. The secondary MP/SCSI Core I/O board is not necessary for full operation; however, without the secondary MP/SCSI Core I/O board, only the top two internal hard disks can be accessed. See Figure 3-1 on page 34.

MP/SCSI Core I/O Board Connections

The MP/SCSI Core I/O board is required to update firmware, access the console, turn partition power on/off, access all but two of the internal peripherals, and use other features of the system.

Connections to the MP/SCSI Core I/O board include the following:

- DB25 Connector, by way of the M cable
This RS232 connector provides connections for a local console, external modem, and a UPS. The server end of the M cable terminates in a DB25 connector. The opposite side of the cable terminates in three DB9 connectors labeled CONSOLE, UPS, and REMOTE.
- 10/100 Base-T LAN RJ45 connector (for LAN and Web Console access).
This LAN uses standby power and is still active if the front panel power switch is off and AC is present.
- Internal LVD Ultra 160 SCSI channel for connections to internal mass storage
- Internal SE Ultra SCSI channel for connection to an internal removable media device.

LAN/SCSI Connections

The LAN/SCSI board is a PCI form factor card that provides the basic external I/O connectivity for the system.

Connections to the LAN/SCSI board include the following:

- PCI-X to PCI-X bridge for multi-device compatibility
- Internal LVD Ultra 160 SCSI channel for connections to internal mass storage
- External LVD Ultra 160 SCSI channel connected to a 68-pin VHDCI connector
- 10/100/1000 Base-T LAN RJ45 connector

The primary LAN interface is located on the LAN/SCSI board installed in the rightmost slot when viewing the system from the back.

Management Processor Access

NOTE To access the Management Processor for the initial installation, the M cable must first be connected to the DB25 connector located on the primary MP/SCSI Core I/O board. The primary MP/SCSI Core I/O board is located in MP/SCSI Core I/O board slot 1 (lower slot).

Setting Up the Customer Engineer Tool (PC)

The Customer Engineer (CE) Tool is usually a laptop. It allows communication with the MP in the HP 9000 rp7420 Server. The MP monitors the activity of either a one partition or a multiple-partition configuration.

During installation, communicating with the MP enables such tasks as:

- Verifying that the components are present and installed correctly
- Setting LAN IP addresses
- Shutting down cell board power

Communication with the MP is established by connecting the CE Tool to the local RS-232 port on the MP/SCSI Core I/O card.

Setting CE Tool Parameters

After powering on the CE Tool, ensure the communications settings are as follows:

- 8/none (parity)
- 9600 baud
- None (Receive)
- None (Transmit)

If the CE Tool is a laptop using Reflection 1, ensure communications settings are in place, using the following procedure:

1. From the Reflection 1 Main screen, pull down the **Connection** menu and select **Connection Setup**.
 - Select **Serial Port**.
 - Select **Com1**
 - Check the settings and change, if required.
Go to **More Settings** to set Xon/Xoff. Click **OK** to close the More Settings window.
 - Click **OK** to close the Connection Setup window.
2. Pull down the **Setup** menu and select **Terminal** (under the **Emulation** tab).
 - Select terminal type VT100 or VT102
 - Click **Apply**.
This option is not highlighted if the terminal type you want is already selected.
3. Click **OK**.

Connecting the CE Tool to the Local RS232 Port on the MP

This connection allows direct communications with the MP. **Only one window can be created** on the CE Tool to monitor the MP. When enabled, it provides direct access to the MP and any partition.

Use the following procedure to connect the CE Tool to the Local RS-232 Port on the MP:

1. Connect one end of a null modem cable (9-pin to 9-pin) (Part Number 5182-4794) to the M cable connector labeled CONSOLE.
2. Connect the other end of the RS-232 cable to the CE Tool.

Turning on Housekeeping Power and Logging in to the MP

After connecting the serial device, log in to the Management Processor (MP). +3.3 V DC Housekeeping power (HKP) (also known as standby power) is active as soon as AC power is applied to the server. As the MP uses housekeeping power, it is possible to log in to the MP even with the power switch in the OFF position. The power switch is a DC power switch that controls +48 V DC.

Before powering up the HP 9000 rp7420 Server server for the first time:

1. Verify that the AC voltage at the input source is within specifications for each server being installed.
2. If not already done so, power on the serial display device.

The preferred tool is the CE Tool running Reflection 1.

To power up the MP, set up a communications link and log in to the MP:

1. Connect the server to AC power.

On the front of the HP 9000 rp7420 Server, a solid green **Standby Power** LED, a solid green **MP Present** LED, and a flashing amber **Attention** LED will illuminate after about 30 seconds.

2. Check the bulk power supply LED for each BPS.

When on, the breakers distribute power to the BPSs. AC power is present at the BPSs:

- When power is first applied. The BPS LEDs will flash amber.
- After approximately 30 seconds have elapsed, the BPS LED will flash green. (If the LED stays amber, the BPS may be defective or the power may not be within specifications.) Observe that the flashing amber BPS LED transitions to a flashing green LED for each BPS.

Refer to power cord policies to interpret LED indicators.

3. Log in to the MP:

- a. Enter **Admin** at the login prompt. The login is case sensitive.

It takes a few moments for the MP prompt to display. If it does not, be sure the laptop serial device settings are correct: 8 bits, no parity, 9600 baud, and None for both Receive and Transmit. Then, try again.

- b. Enter **Admin** at the password prompt. The password is case sensitive.

The MP Main Menu is displayed:

Figure 4-7 MP Main Menu

```
                Welcome to the
                rp7420 Management Processor
(c) Copyright 1995-2003 Hewlett-Packard Co., All Rights Reserved.
                Version A.0.017

MP MAIN MENU:
  CO: Consoles
  UFP: Virtual Front Panel (partition status)
  CM: Command Menu
  CL: Console Logs
  SL: Show Event Logs
  HE: Help
  X: Exit Connection

MP> _
```

Configuring LAN Information for the MP

This section describes how to set and verify the server MP LAN port information. LAN information includes the MP network name, the MP IP address, the subnet mask, and gateway address. This information is provided by the customer.

To set the MP LAN IP address:

Step 1. At the MP Main Menu prompt (*MP>*), enter **cm.** to enter the MP Command Menu.

Step 2. From the MP Command Menu prompt (*MP:CM>*), enter **lc** (for LAN configuration).

The screen displays the default values and asks if you want to modify them. Write down the information or log it to a file, as it may be required for future troubleshooting. See Figure 4-8.

NOTE If the Command Menu is not shown, enter **q** to return to the MP Main Menu, then enter **cm.**

Figure 4-8The **lc** Command Screen

```
MP:CM> LC

This command modifies the LAN parameters.

Current configuration of MP LAN interface
MAC address   : 00:30:6e:05:09:24
IP address    : 15.99.83.215   (0x0f6353d7)
Hostname      : quartz-s
Subnet mask   : 255.255.255.0   (0xfffff00)
Gateway       : 15.99.83.254   (0x0f6353fe)
Status        : UP and RUNNING
AutoNegotiate : Enabled
Data Rate     : 100 Mb/s
Duplex        : Half
Error Count   : 0
Last Error    : none

Do you want to modify the configuration for the customer LAN? (Y/[N]) q
MP:CM>
```

NOTE The value in the “IP address” field has been set at the factory. Obtain the actual LAN IP address from the customer.

Step 3. At the prompt, *Do you want to modify the configuration for the customer LAN?*, enter **y**

The current IP address is shown; and the following prompt displays: *Do you want to modify it?* (**Y/[N]**)

Step 4. Enter **y**.

Step 5. Enter the new IP address.

The customer must provide this address for network interface 0.

Configuring LAN Information for the MP

Step 6. Confirm the new address.

Step 7. Enter the MP Hostname.

This is the host name for the MP LAN. The name can be as many as 64 characters in length, and include alphanumeric characters, - (dash), _ (under bar), . (period), or a space. HP recommends that the name be a derivative of the complex name. For example, Acme.com_MP.

Step 8. Enter the LAN parameters for the *Subnet mask* and *Gateway address* fields.

This information must come from the customer.

Step 9. When Step 8 is completed, the system indicates the parameters have been updated and returns to the MP Command Menu prompt (*MP:CM>*).

Step 10. To check the LAN parameters and status, enter the *ls* command at the MP Command Menu prompt (*MP:CM>*).

Step 11. A screen similar to the following is displayed, allowing verification of the settings:

Figure 4-9The *ls* Command Screen

```
MP:CM> LS

Current configuration of MP LAN interface
MAC address  : 00:30:6e:05:09:24
IP address   : 15.99.83.215   (0x0f6353d7)
Hostname     : quartz-s
Subnet mask  : 255.255.255.0   (0xffffffff00)
Gateway      : 15.99.83.254   (0x0f6353fe)
Status       : UP and RUNNING
AutoNegotiate : Enabled
Data Rate    : 100 Mb/s
Duplex       : Half
Error Count  : 0
Last Error   : none

MP:CM>
```

Step 12. To return to the MP Main Menu, enter *ma*.

Step 13. To exit the MP, enter *x* at the MP main menu.

Accessing the Management Processor via a Web Browser

Web browser access is an embedded feature of the MP/SCSI Core I/O card. The Web browser allows access to the server through the LAN port on the core I/O card. Initial MP configuration must be done from the local console connected to the Local RS232 port.

NOTE The MP/SCSI Core I/O card has a separate LAN port from the system LAN port. It requires a separate LAN drop, IP address, and networking information from that of the port used by HP-UX.

Before starting this procedure, the following information is required:

- IP address for the MP LAN
- Subnet mask
- Gateway address
- Host name (this is used when messages are logged or printed)

To configure the LAN port for a Web browser, perform the following steps:

Step 1. Connect to the MP/SCSI Core I/O using a serial connection.

Step 2. Configure the MP/SCSI Core I/O LAN. Refer to “Configuring LAN Information for the MP” on page 55.

Step 3. Type **CM** to enter the Command Menu.

Step 4. Type **sa** at the MP:CM> prompt to display and set MP remote access.

Figure 4-10 Example sa Command

```
MP:CM> sa
This command displays and allows modification of access parameters.

T - Telnet access           : Enabled.
M - Modem access           : Enabled.
W - Web Console            : Enabled (SSL NOT active).
N - Network Diagnostics   : Disabled.
I - IPMI Lan access       : Disabled.

Select access mode to change : w

The following options are available for Web access:
  1 - Web access disabled
  2 - Web access enabled
  3 - Secure web access enabled
Select option:
```

Step 5. Enter **w** to modify web access mode.

Step 6. Enter **2** to enable web access.

Step 7. Launch a Web browser on the same subnet using the IP address for the MP LAN port.

Figure 4-11 Browser Window

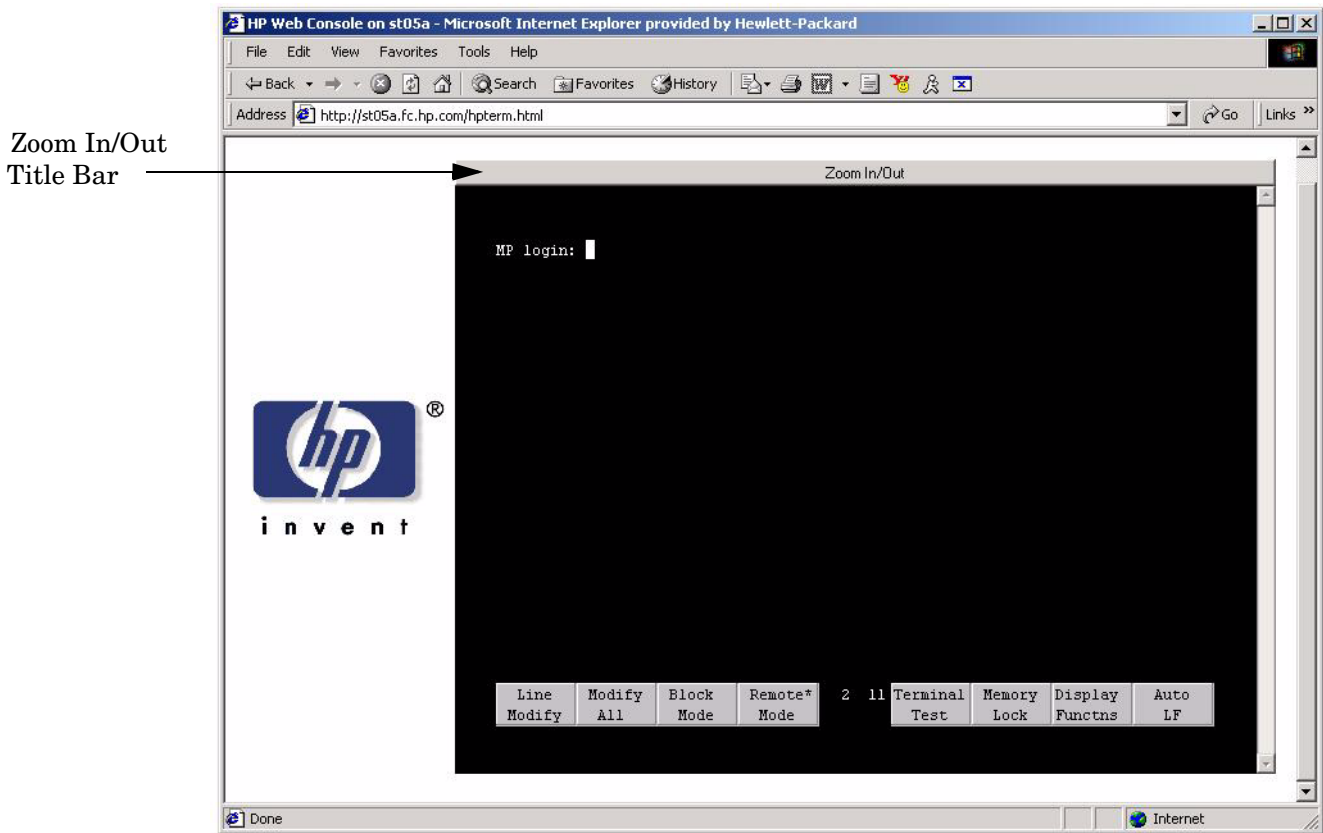

Step 8. Select the emulation type you want to use.

Step 9. Click anywhere on the Zoom In/Out title bar to generate a full screen MP window.

Step 10. Login to the MP when the login window appears.

Access to the MP via a Web browser is now possible.

Verifying Presence of the Cell Boards

To perform this activity, either connect to the MP using a console, or connect the CE Tool (laptop) to the RS-232 Local port on the MP/SCSI Core I/O.

After logging in to the MP, verify that the MP detects the presence of all the cells installed in the cabinet. It is important for the MP to detect the cell boards. If it does not, the partitions will not boot.

To determine if the MP detects the cell boards:

1. At the MP prompt, enter **cm**.

This displays the Command Menu. The Command Menu enables viewing or modifying the configuration and viewing the utilities controlled by the MP.

To view a list of the commands available, enter **he**. Press **Enter** to see more than one screen of commands. Use the **Page Up** and **Page Down** keys to view the previous or next screen of commands. To exit the Help Menu, enter **q**.

2. From the command prompt (MP:CM>), enter **du**.

The **du** command displays the MP bus topology. A screen similar to the following is displayed:

Figure 4-12 The du Command Screen

```

MP:CM> DU

The following MP bus devices were found:
+-----+
|  |  |  | Sys |  | PCI |  | BPS |  |
|Cab| MP | Bkpln| Cells | Domain|  |  |  |
| # |  |  | 0 1 | 0 1 | 0 1 |  |
+-----+
| 0 | * | * | * * | * * | * * |  |
+-----+

MP:CM>

```

There will be an asterisk (*) in the column marked MP.

3. Verify that there is an asterisk (*) for each of the cells installed in the cabinet, by comparing what is in the *Cells* column with the cells physically located inside the cabinet.

Figure 4-12 shows that cells are installed in slots 0 and 1. In the cabinet, cells should be physically located in slots 0 and 1.

Booting the HP 9000 rp7420 Server

Powering on the server can be accomplished by either pressing the power switch on the front panel or by using the PE command to power up the cabinet or complex at the MP command menu (MP:CM>).

If only a serial console is available to the system, monitor the system as it boots.

If a LAN connection to the MP/SCSI Core I/O is available, review server activity for each partition configured, while the server powers up and boots. Windows can be opened for the complex and for each partition. HP recommends that at least two windows be opened:

1. A window showing all activity in the complex. Following the installation procedure in this manual causes a window to be opened at startup.

To display activity for the complex:

- Either open a separate Reflection window and connect to the MP or connect through a Web Browser.
- From the MP Main Menu, select the VFP command with the s option.

2. A window showing activity for a single partition.

To display activity for each partition as it powers up:

- Either open a separate Reflection window and connect to the MP or connect through a Web Browser.
- Select the VFP command and select the desired partition to view.

There should be no activity on the screen at this point in the installation process.

NOTE More than one window cannot be opened using a serial display device.

To power on the server:

1. Switch the power switch at the front of the server to **On**. The following events occur:
 - Power is applied to the server.
 - PDC starts to run on each cell.
 - The cell self test executes.
 - Hardware initializes for the server.
 - Console communication is established.
2. Once the cell has joined the partition or once boot is blocked (BIB) is displayed at the virtual front panel (VFP), return to the MP Main Menu by entering **Ctrl-B**.
3. Enter **co** to enter console mode.
4. Enter the partition number of the partition to boot.
5. Press **Enter**.

Selecting a Boot Partition using the Management Processor

At this point in the installation process, the hardware is set up, the MP is connected to the LAN, the AC and DC power have been turned on, and the self test is completed. Now the configuration can be verified.

After the DC powers on and the self test is complete, use the MP to select a boot partition.

1. From the MP Main Menu, enter **cm**.
2. From the MP Command Menu, enter **bo**.
3. Select the partition to boot. Partitions can be booted in any order.
4. Return to the MP Main Menu by entering **ma** from the Command Menu
5. Enter the Console Menu by typing **co** at the MP Main Menu.

To exit the MP, the **x** command is used to return to the Boot Console Handler main menu.

Verifying the System Configuration using Boot Console Handler

From the BCH main menu, enter **in** to go the Information Menu. Use the corresponding command from the menu to verify the type and quantity of processors, memory, and I/O cards:

- **pr** (Processors)
- **me** (Memory)
- **io** (Check the PCI device information to determine if the values match the devices installed in the server)

Once the parameters have been verified, use the **ma** command to return to the BCH Main Menu.

Booting HP-UX using Boot Console Handler

If Instant Ignition was ordered, HP-UX will have been installed in the factory at the Primary Path address. If HP-UX is at a path other than the Primary Path, use the **pa** (path) command (from the Configuration Menu) to set boot path.

1. Main Menu: Enter command or Menu> **co**
2. Configuration Menu> **pa pri xx/xx/xx**
3. Configuration Menu> **ma**

Once the Primary Path has been set, use the **bo** (boot) command (from the Main Menu) to boot HP-UX.

1. Main Menu: Enter command or Menu> **bo pri**
2. The following prompt is displayed:

```
Do you wish to stop at the ISL prompt prior to booting (y/n)?
```

```
Enter n.
```

NOTE If the partition fails to boot or if the server was shipped without Instant Ignition, booting from a DVD that contains the operating system and other necessary software might be required.

Adding Processors with Instant Capacity On Demand

The Instant Capacity On Demand (iCOD) program provides access to additional CPU resources beyond the amount that was purchased for the server. This provides the ability to activate additional CPU power for unexpected growth and unexpected spikes in workloads.

Internally, iCOD systems physically have more CPUs, called iCOD CPUs, than the number of CPUs actually purchased. These iCOD CPUs reside in the purchased system, but they belong to HP and therefore are HP assets. A nominal “Right-To-Access Fee” is paid to HP for each iCOD processor in the system. At any time, any number of iCOD CPUs can be “activated.” Activating an iCOD CPU automatically and instantaneously transforms the iCOD CPU into an instantly ordered and fulfilled CPU upgrade that requires payment. After the iCOD CPU is activated and paid for, it is no longer an iCOD CPU, but is now an ordered and delivered CPU upgrade for the system.

The most current information on installing, configuring, and troubleshooting iCOD can be found at <http://docs.hp.com>

NOTE Ensure that the customer is aware of the iCOD email requirements. Refer to <http://docs.hp.com> for further details.

Using the Checklist

The following checklist is an installation aid and should be used only after you have installed several systems using the detailed procedures described in the body of this manual. This checklist is a compilation of the tasks described in this manual, and is organized as follows:

PROCEDURES The procedures outlined in this document in order

IN-PROCESS The portion of the checklist that allows you to comment on the current status of a procedure

COMPLETED The final check to ensure that a step has been completed and comments

Major tasks are in **bold type**, sub tasks are indented.

Table 4-2 Factory-Integrated Installation Checklist

PROCEDURE		IN-PROCESS		COMPLETED	
		Initials	Comments	Initials	Comments
Obtain LAN information					
Verify site preparation					
	Site grounding verified				
	Power requirements verified				
Check inventory					
Inspect shipping containers for damage					
Unpack SPU cabinet					
	Allow proper clearance				
	Cut polystrap bands				
	Remove cardboard top cap				
	Remove cardboard wrap from the pallet				
	Remove bolts holding down the ramps and remove the ramps				
	Remove antistatic bag				
	Check for damage (exterior and interior)				
	Position ramps				
	Roll cabinet off ramp				
Unpack the peripheral cabinet (if ordered)					

Table 4-2 Factory-Integrated Installation Checklist (Continued) (Continued)

PROCEDURE		IN-PROCESS		COMPLETED	
		Initials	Comments	Initials	Comments
	Unpack other equipment				
	Remove and dispose of packaging material				
	Move cabinet(s) and equipment to computer room				
	Install non-factory, integrated I/O cards (if required)				
	Move cabinets into final position				
	Position cabinets next to each other (approximately 1/2 inch)				
	Adjust leveling feet				
	Install anti-tip plates				
	Inspect cables for proper installation				
	Set up CE tool and connect to Remote RS-232 port on MP				
	Apply power to cabinet (Housekeeping)				
	Check power to BPSs				
	Log in to MP				
	Set LAN IP address on MP				
	Connect customer console				
	Set up network on customer console				
	Verify LAN connection				
	Verify presence of cells				
	Power on cabinet (48 V)				
	Verify system configuration and set boot parameters				
	Set automatic system restart				
	Boot partitions				
	Configure remote login (if required). See Appendix B.				

Table 4-2 Factory-Integrated Installation Checklist (Continued) (Continued)

PROCEDURE		IN-PROCESS		COMPLETED	
		Initials	Comments	Initials	Comments
Verify remote link (if required)					
	Select PCI card slot				
	Install PCI card				
	Verify installation				
Route cables using the cable management arm					
Install other peripherals (if required)					
Perform visual inspection and complete installation					
Set up network services (if required)					
Enable iCOD (if available)					
Final inspection of circuit boards					
Final inspection of cabling					
Area cleaned and debris and packing materials disposed of					
Account for tools					
Dispose of parts and other items					
Make entry in Gold Book (recommended)					
Customer acceptance and signoff (if required)					

A

ac power
voltage check, 46
AC power receptacles, 6

B

backplane
mass storage, 10
PCI, 7, 9
system, 9
booting HP-UX, 61
BPS (Bulk Power Supply), 53
bulk power supply, 4

C

cell board, 4, 5, 51, 59
verifying presence, 59
checklist
installation, 63
cm (Command Menu) command, 59
co (Console) command, 60
commands
cm (Command Menu), 59
co (Console), 60
CTRL-B, 60
di (Display), 61
du (display MP bus topology), 59
vfp (Virtual Front Panel), 60

D

di (Display) command, 61
disk
internal, 10, 50
du (display MP bus topology) command, 59

F

front panel display, 7

G

Gateway, 55

H

Hostname, 55
housekeeping power, 53
HP-UX, booting, 61

I

iCOD
definition, 62
email requirements, 62
installation
checklist, 63
IP address, 55
default, 55

L

LAN parameters, 55
LAN status, 55

lc (LAN configure) command, 55
LED

Attention, 53
Bulk Power Supply, 53
SP Active, 53
Standby Power Good, 53

Lift Handle, 18

login name

MP, 53

ls (LAN status) command, 56

M

MAC address, 55
Management Processor (MP), 51
mass storage, 4
mass storage backplane, 10
MP
login name, 53
password, 53
MP (Management Processor)
logging in, 53
powering on, 53
MP/SCSI, 50
MP/SCSI Core I/O, 6, 9, 50, 51

N

null modem cable
connectivity, 52
part number, 52

P

password
MP, 53
PCI backplane, 7, 9
PCI power supply, 4
PCI-X, 4
PDC
Processor Dependent Code, 60
power
applying cabinet, 60
cabinet switch, 60
housekeeping, 53, 60
Processor Dependent Code
PDC, 60

R

Reflection 1, 52, 60
RonI Lifter, 22

S

SCSI ribbon cable, 6
serial display device
connecting, 51, 52
recommended windows, 60
setting parameters, 51
Subnet mask, 55
system backplane, 6, 9
system configuration, verifying, 61

Index

U

unpacking
 inspecting for damage, 12

V

verifying system configuration, 61
voltage check, 46