

hp StorageWorks  
Ultrium tape drive

getting started guide

internal model



**ULTRIUM**  
LTO

Ultrium 230i, 460i, 960i



i n v e n t

**open this flap for quick  
start installation poster**



1

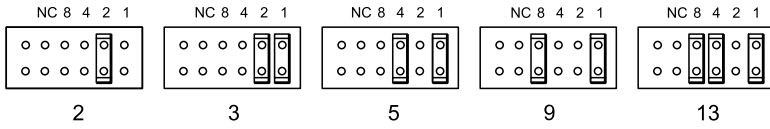
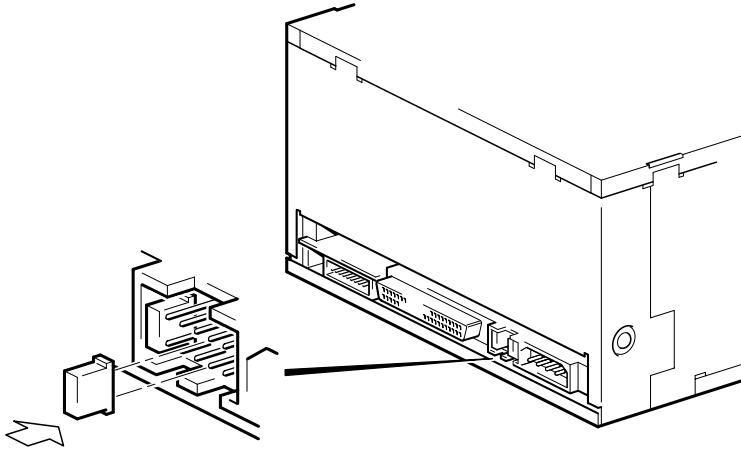

4

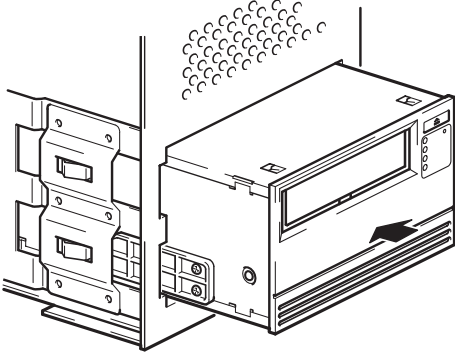

5

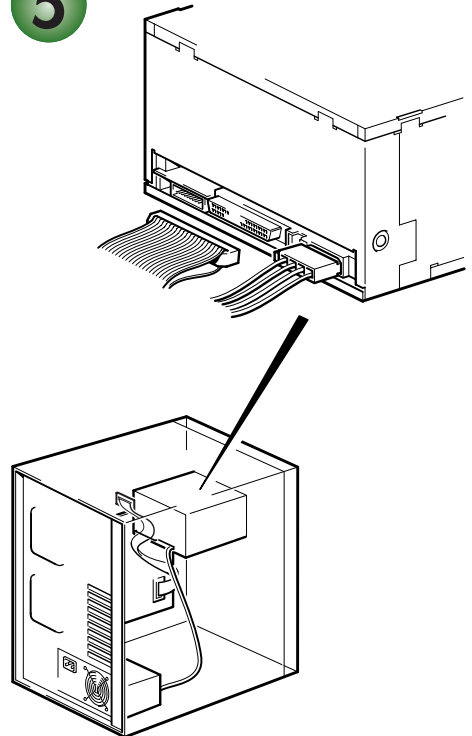

2

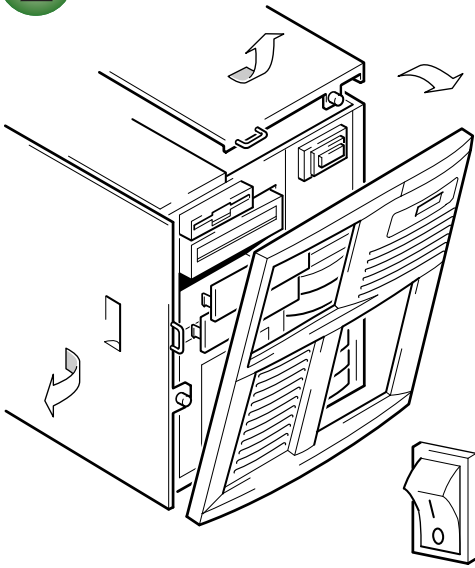

3

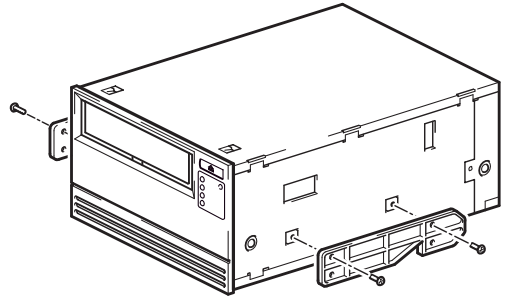

6

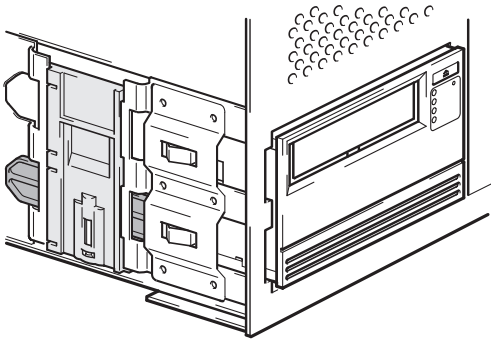

# Internal drives - contents

## Pre-Installation

Before you start	page 3
Backup software and drivers	page 5
Using the CD-ROM	page 7

## Installing the tape drive

Step 1: Check the SCSI connection	page 9
Step 2: Check the drive's SCSI ID	page 11
Step 3: Prepare the mounting bay	page 13
Step 4: Attach mounting hardware	page 15
Step 5: Install the drive	page 17
Step 6: Attach power and SCSI cables	page 19
Step 7: Secure the drive	page 21
Step 8: Verify installation	page 23

## Using the tape drive

Your HP StorageWorks Ultrium tape drive	page 25
Use the correct media	page 27
Register your tape drive	page 29
Using HP OBDR	page 31
Diagnostic tools	page 33
Optimizing performance	page 35
Troubleshooting	page 37
Understanding the LEDs	page 42
Problems with cartridges	page 46
Other sources of information	page 48
Replacing your tape drive	page 49

Hewlett-Packard Company makes no warranty of any kind with regard to this material, including, but not limited to, the implied warranties of merchantability and fitness for a particular purpose. Hewlett-Packard shall not be liable for errors contained herein or for incidental or consequential damages in connection with the furnishing, performance, or use of this material.

This document contains proprietary information, which is protected by copyright. No part of this document may be photocopied, reproduced, or translated to another language without the prior written consent of Hewlett-Packard. The information contained in this document is subject to change without notice.

Linear Tape-Open, Ultrium, Ultrium Logo, Ultrium and Ultrium Logo are U.S. trademarks of HP, IBM and Certance (previously Seagate).

Patented under one or more of U.S. Patents Nos. 5,003,307; 5,016,009; 5,463,390; 5,506,580; held by Hi/fn, Inc.

Microsoft®, MS-DOS®, MS Windows®, Windows® and Windows NT® are U.S. registered trademarks of Microsoft Corporation.

UNIX® is a registered trademark of The Open Group.

Hewlett-Packard Company shall not be liable for technical or editorial errors or omissions contained herein. The information is provided "as is" without warranty of any kind and is subject to change without notice. The warranties for Hewlett-Packard Company products are set forth in the express limited warranty statements for such products. Nothing herein should be construed as constituting an additional warranty.

Printed in the U.K.

## Product Details

Write your tape drive details here so you can find them easily if you need them. The model name is on the front of the drive and the product and serial numbers are on a label on the bottom of the drive.

<b>Model (type of drive):</b>	
<b>Model (number):</b>	
<b>Serial (number):</b>	
<b>Date purchased/installed:</b>	
<b>SCSI ID:</b>	

# Before you start

HP StorageWorks Ultrium tape drives are designed to operate on a low voltage differential SCSI bus (LVDS). This guide describes how to install:

- **HP StorageWorks Ultrium 960 tape drives**, high-performance Ultra 320 SCSI devices with a maximum burst transfer speed of 320 MB/second.
- **HP StorageWorks Ultrium 460 tape drives**, high-performance Ultra 160 SCSI devices with a maximum burst transfer speed of 160 MB/second.
- **HP StorageWorks Ultrium 230 tape drives**, high-performance Ultra 2 SCSI devices with a maximum burst transfer speed of 80 MB/second.

Before starting to install your tape drive, you should consider the following:

## Which operating systems are supported?

HP StorageWorks Ultrium drives can be connected to servers running under Windows®, NetWare, HP-UX, Tru64, Linux and several other industry-standard operating systems. Refer to the “HP StorageWorks Tape Software Compatibility” topic on our World Wide Web site ([www.hp.com/go/connect](http://www.hp.com/go/connect)) for more information about the operating system versions that are supported.

## How do I connect the drive to my server?

The tape drive is installed into a spare drive bay in your server (or into an HP Rack-Mount Option Kit) and is attached to the SCSI bus of the host server via a spare connection on the internal SCSI ribbon cable.

You will need a properly installed and configured SCSI host bus adapter (HBA) or a built-in SCSI controller on your server with a correctly terminated, LVDS-compatible ribbon cable with a spare 68-pin, high density (HD), wide SCSI connector.

For optimum performance your tape drive should only be connected to a SCSI bus that can transfer data at a rate that supports the tape drive’s maximum burst transfer speed, see Table 1, “supported SCSI bus types,” on page 9, and it should be the only device on the SCSI bus. Do **not** attach the drive to the same SCSI bus as your disk drive or RAID controller.

## How can I check the SCSI bus?

We strongly recommend that you use HP Library & Tape Tools to check your server’s current SCSI configuration (see “Step 2: Check the drive’s SCSI ID” on page 11)). This will provide information about the SCSI bus and the SCSI IDs in use.

HP Library & Tape Tools is the recommended diagnostic and support tool for your HP tape storage product. It is available on the CD shipped with your product or as a free download from the HP web site and is supported on nearly all major operating systems.

See [www.hp.com/support/tapetools](http://www.hp.com/support/tapetools) for compatibility information, updates and the latest version of the tool.

# What are the mounting requirements for the tape drive?

## Mounting bay

You need one industry-standard, 5¼-inch, full-height bay in which to install the HP StorageWorks Ultrium tape drive. Power requirements are:

Voltage	Typical Current		Maximum Current
	Ultrium 460	Ultrium 230	
5 V	3.2 A	5.2 A	6.3 A
12 V	0.7 A	0.7 A	2.75 A

## Mounting hardware

For many servers, no mounting tray or rails are required. Devices simply slide into the server's chassis and are fixed with screws. Other servers have built-in trays or rails.

Rail kits for a number of industry-standard servers may be available. For more details refer to: [www.hp.com/go/connect](http://www.hp.com/go/connect).

Some servers use non-standard mounting rails and do not include spares. If this is the case with your system, you will have to order these accessories from the server manufacturer before you can install the tape drive.

## Airflow requirements

The server **must** provide forced cooling and be capable of drawing 6 cfm (0.17 m<sup>3</sup>/minute or 10.08 m<sup>3</sup>/hour) of air through the tape drive at up to 35 C ambient operation. This rises to 8 cfm for up to 40 C ambient operation.

Ensure that all fans in your server are in place and operational, and make sure that empty bays have the appropriate blanking plates installed so that airflow is maintained.

## Do I need additional items for installation?

- You may also need mounting hardware. See above.
- If you do not have a spare, suitably rated SCSI connector on your server, you must install a new HBA (also known as a SCSI card). The SCSI bus rating should match or be higher than the SCSI rating of your tape drive. See Table 1, "supported SCSI bus types," on page 9 for recommended HBAs. For specific details relevant to your server model please refer to [www.hp.com/go/connect](http://www.hp.com/go/connect). You will need to purchase and install the new HBA into an unused, 64-bit PCI expansion slot within your server before installing your tape drive. (The kit can also be installed in a 32-bit PCI expansion slot, but this will limit performance on higher-performance drives, such as Ultrium 960.)

Refer to our World Wide Web site for recommended products, configurations and ordering information: [www.hp.com/go/connect](http://www.hp.com/go/connect) or [www.hp.com/support/ultrium](http://www.hp.com/support/ultrium).



# Backup software and drivers

## Backup software

For optimum performance it is important to use a backup application that is appropriate for your system's configuration. In a direct attach configuration, where the tape drive is attached to a standalone server, you can use backup software that is designed for a single-server environment. In network configurations you will need backup software that supports enterprise environments. HP, Veritas, Yosemite, Legato and Computer Associates all provide suitable products. Further details about these and other products that may be appropriate can be found on our connectivity web site.

- 1 Go to our connectivity web site: [www.hp.com/go/connect](http://www.hp.com/go/connect).
- 2 Select software compatibility.
- 3 Select your combination of operating system and tape drive model in the table. A list of supported backup applications is displayed. This will also tell you whether your configuration is compatible with HP One-Button Disaster Recovery, HP OBDR. (All HP StorageWorks Ultrium tape drives support HP OBDR. However, you can only use this feature, if your system configuration and backup application also support it. See "Using HP OBDR" on page 31.)
- 4 Make sure you have a backup application that supports your HP StorageWorks Ultrium tape drive and download any upgrades or patches, if required.

## Drivers

### Windows users

After you connect the tape drive, insert the *HP StorageWorks Tape* CD-ROM and follow the link to download the HP driver from our web site: [www.hp.com/support](http://www.hp.com/support), see "Step 8: Verify installation" on page 23. Refer to the accompanying README file for specific installation instructions for Windows 2000, Windows XP and Windows Server 2003 drivers.

**Note:** We recommend that you install drivers from the web link on the CD-ROM rather than the Windows Hardware Installation Wizard, because you can also use HP Library & Tape Tools software on the CD-ROM to verify that your installation is correct (see "Step 8: Verify installation" on page 23). If you do not have internet access, you can also install drivers directly from the *HP StorageWorks Tape* CD-ROM, but these may not be the latest versions available.

### UNIX and OpenVMS users

The recommended backup applications use the operating system's standard, built-in device drivers. To upgrade drivers we recommend that you patch to the latest version of the operating system, following the instructions in the patch documentation. You will also find information about configuring device files in the *Configuration Guides* on the CD-ROM.

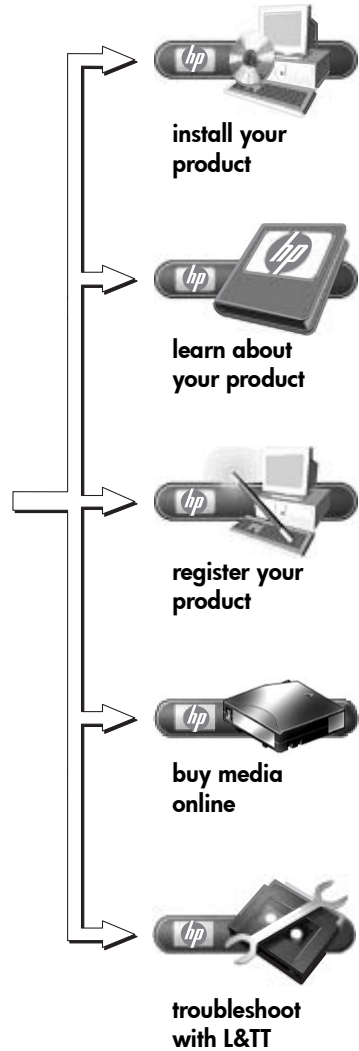

Figure 1: the *HP StorageWorks Tape* CD-ROM

# Using the CD-ROM

The *HP StorageWorks Tape* CD-ROM is a central source of information about your tape drive with utilities for getting the best performance from your tape drive.

Use the *HP StorageWorks Tape* CD-ROM to check installation, as described in this guide, and to verify and troubleshoot performance after installation. It helps you to:

- Install your product, which includes access to drivers, an installation check, and performance information and tools
- Learn about your product, which includes an online *User's Guide* and *UNIX* and *OpenVMS Configuration Guides*.
- Register you product
- Buy media online
- Troubleshoot with HP Library & Tape Tools.

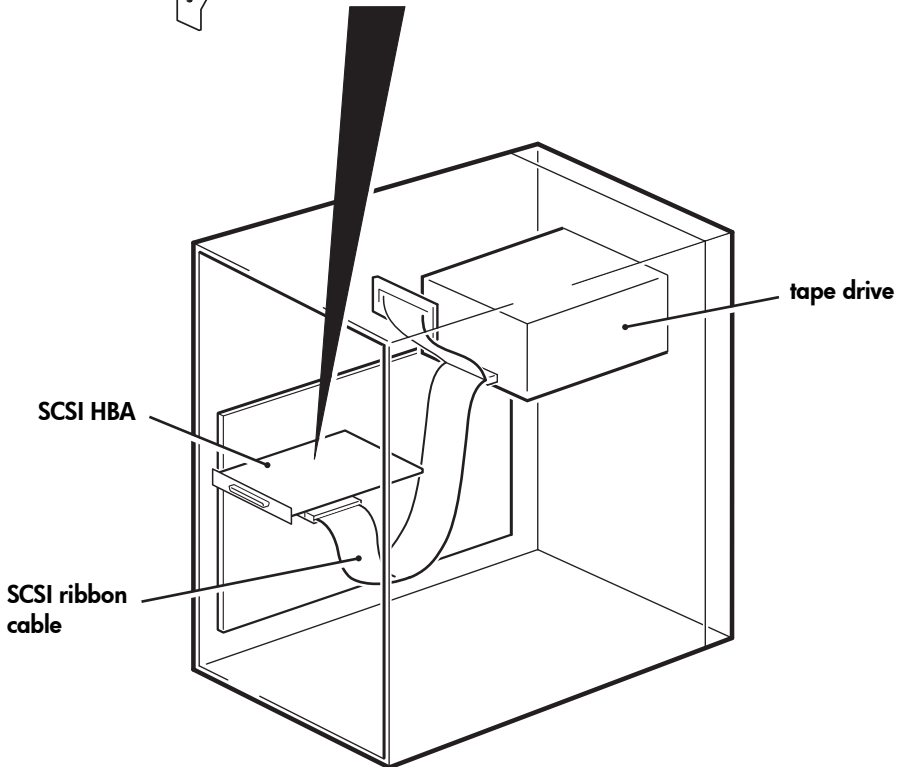
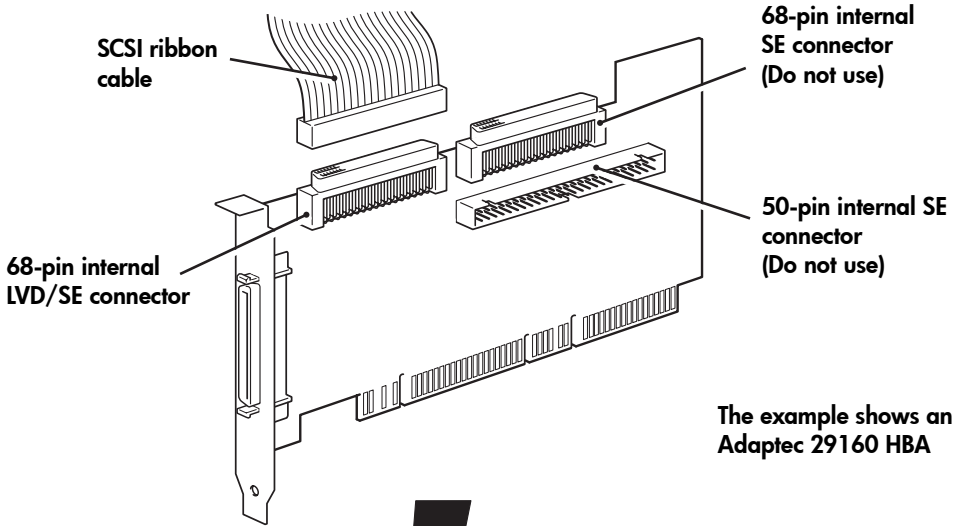
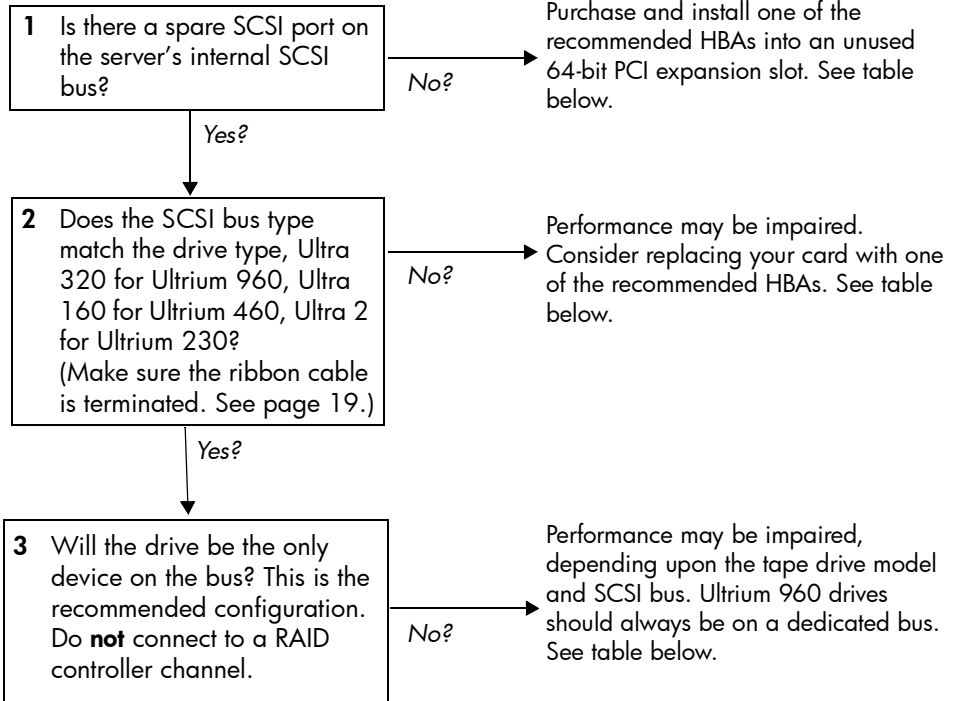

Figure 2: checking the SCSI connection

# Step 1: Check the SCSI connection

Use the following questions to help you check your SCSI connection. Most users can use HP Library & Tape Tools to check the SCSI bus, see page 33. If you answer 'Yes' to all these questions, you are ready to install your tape drive. If you answer 'No', you will probably need to purchase and install additional items.

For product details, go to [www.hp.com/go/connect](http://www.hp.com/go/connect).



SCSI Bus Type	Transfer Speed	Recommended for		
		960	460	230
Ultra 320 LVD	Up to 320 MB/s	Yes, one drive only per bus	Yes, for up to two 460 drives per bus	Yes
Ultra 160 LVD	Up to 160 MB/s	Acceptable	Yes, one drive only per bus	Yes, for up to two 230 drives per bus
Ultra 2 LVD	Up to 80 MB/s	No	Acceptable	Yes, one drive only per bus
Single-ended, wide	Up to 40 MB/s	No	No	Acceptable, but it will restrict performance.
		Do <b>not</b> connect to a narrow SCSI bus.		
High Voltage Differential	Up to 40 MB/s	No. The drive will not work and you may damage the drive or controller.		

**table 1: supported SCSI bus types**

**Note** If you attach your drive to a higher-rated SCSI bus, the internal SCSI cable should be of the same specification as the SCSI HBA. For example, if you connect an Ultrium 460 to an Ultra 320 bus, make sure that the internal cable supports Ultra 320.

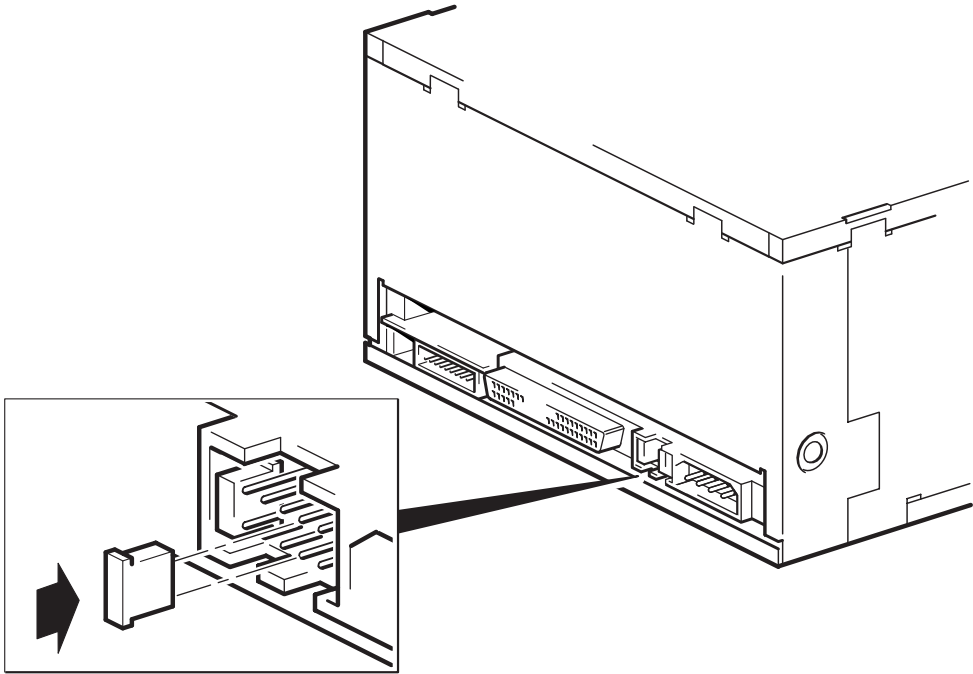

**Example SCSI IDs**

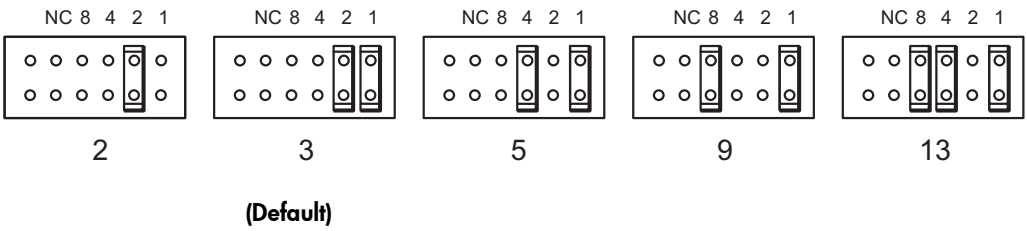

**Figure 3: checking the SCSI ID**

## Step 2: Check the drive's SCSI ID

Your HP StorageWorks Ultrium drive is shipped with a default SCSI ID of 3, but it can be assigned any *unused* ID between 0 and 15. Do not use SCSI ID 7, which is reserved for the SCSI controller, or SCSI ID 0, which is typically assigned to the boot disk.

- 1 Determine whether you need to change the SCSI ID from the default of 3.

For most operating systems you can run HP Library & Tape Tools from the HP StorageWorks Tape CD-ROM to check your computer's SCSI configuration. This will provide information about the SCSI bus and the SCSI IDs currently in use. To do this, select the 'troubleshoot with L&TT' option from the CDRROM menu. (See also page 33.)

For UNIX systems, check the *UNIX Configuration Guide* on the *HP StorageWorks Tape* CD-ROM, for instructions on how to determine the SCSI IDs of existing devices.

**Caution** Static electricity can damage electronic components. Always wear an antistatic wriststrap if possible. If not, to equalize the electromagnetic charges, touch a bare metal part of the server (such as the back plate) before you remove the tape drive from its bag.

- 2 Change the tape drive's SCSI ID, if necessary.

The SCSI ID is set using jumpers on a set of pins at the rear of the drive. Move the jumpers carefully to the pattern corresponding to the ID you want, see Figure 3. Spare jumpers are provided with the drive.

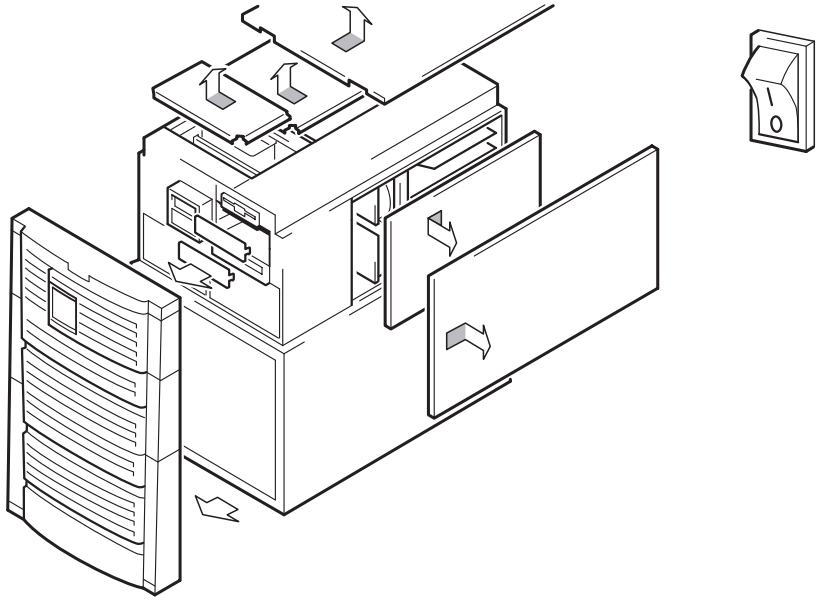

**Figure 4a: preparing mounting bay in a typical HP AlphaServer**

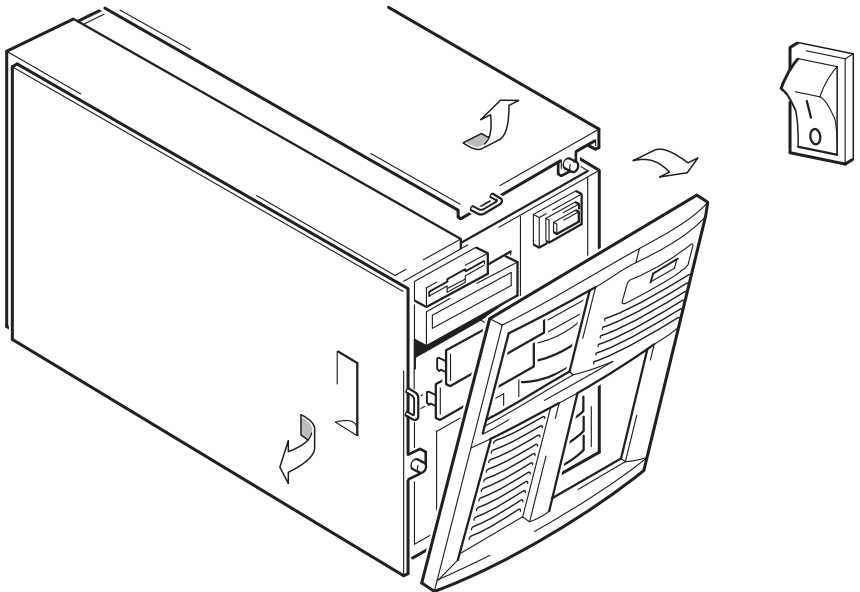

**Figure 4b: preparing mounting bay in a typical HP ProLiant server**



## Step 3: Prepare the mounting bay

**Warning** To avoid personal injury or damage to the server or tape drive, ensure that the server is disconnected from the mains power supply while you install the drive.

**Caution** Static electricity can damage electronic components. Always wear an antistatic wriststrap if one is available. If not, after you have disconnected power from the server and removed the cover, touch a bare metal part of the chassis. Similarly, touch a bare metal part of the drive before installing it.

- 1 Assemble the necessary tools and materials:
  - Phillips screwdriver
  - Flat-bladed screwdriver (if your server uses slotted screws)
  - Torx screwdriver (if your server uses torx screws)
  - Your server manuals (for reference during installation)
- 2 Perform a normal system shutdown and turn off the server and any connected peripherals.
- 3 Remove the cover and front panel from the server, as detailed in your server's documentation. As you work inside the server, you may have to disconnect the SCSI cable or power cable from other devices to maneuver the new drive into place. If you have to do this, make a note of their position and connections so you can put them back correctly later.
- 4 Remove the front filler panel from a full-height, 5¼-inch bay of your server, as illustrated. With some servers, such as the HP AlphaServer ES40, you must also remove the half-height device divider.

The server must provide forced cooling and be capable of drawing 6 cfm (0.17 m<sup>3</sup>/minute or 10.08 m<sup>3</sup>/hour) of air through the tape drive at up to 35 C ambient operation. This rises to 8 cfm for up to 40 C ambient operation. Ensure that empty bays have the appropriate blanking plates installed so that airflow is maintained.

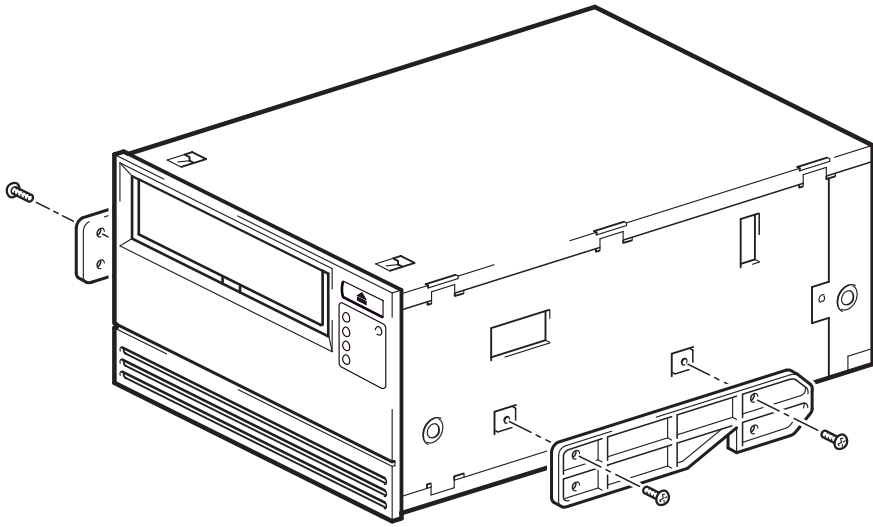

**Figure 5a: attaching mounting rails in a typical HP ProLiant 530 or 570 server**

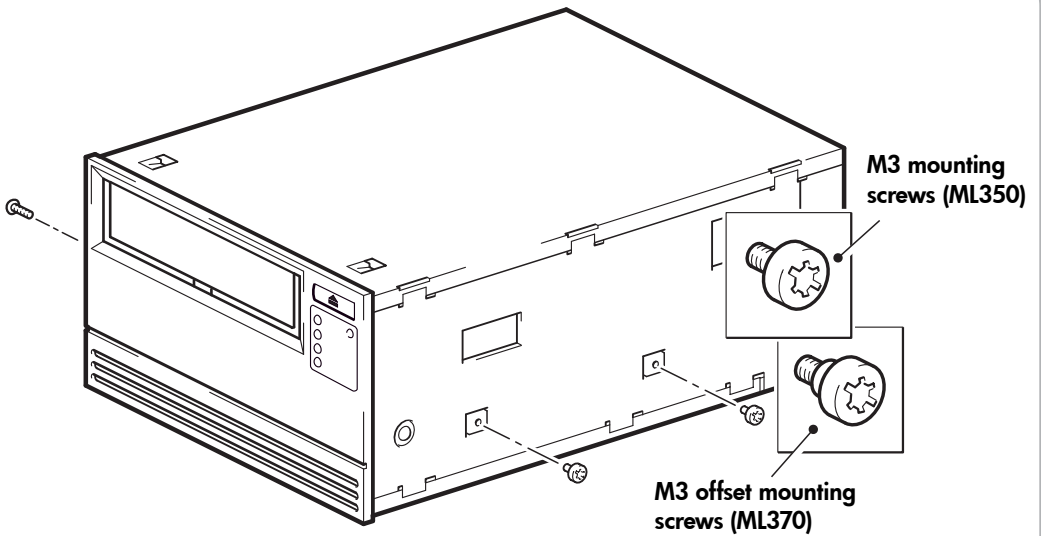

**Figure 5b: attaching mounting screws in a typical HP ProLiant 350 or 370 server**

# Step 4: Attach mounting hardware

If your server requires special rails or other hardware to install the tape drive, mount them on the tape drive in this step.

*If your server does not require special mounting hardware, proceed to “Step 5: Install the drive” on page 17 now. For example, HP AlphaServers do not require special mounting hardware.*

## HP ProLiant servers

Different models of server require different mounting methods. The server may also incorporate a locking mechanism to hold the tape drive in place. See “Step 7: Secure the drive” on page 21.

Please check your HP ProLiant server documentation to ascertain the correct method of mounting, and to check whether mounting hardware is provided with the server.

### Mounting rails

Some HP ProLiant servers, such as ML530 and ML570, require mounting rails. These may be metal or plastic rails attached to the server's drive bay filler panel.

- 1 Use a regular Phillips screwdriver to attach the appropriate rails. Use the M3 screws provided with the tape drive, as shown in Figure 5a.

Ensure you do use the M3 screws provided - the rails may be attached to the filler panel by screws of a different thread/size type and these should not be used. If in doubt, refer to your HP ProLiant server documentation.

### Mounting screws

Other HP ProLiant server models, such as ML350 and ML370, only require the use of special locating screws with no mounting rail.

- 1 Use a T8 Torx screwdriver to attach the appropriate screws. You may need to purchase the M3 screws separately. Position the screws, as shown in Figure 5b.
  - HP ProLiant ML350: Use M3 mounting screws. These have a thicker head than the standard M3 screws.
  - HP ProLiant ML370: Use M3 offset mounting screws. These have a thick offset piece and a thicker head than the standard M3 screws.

## Other servers

- 1 Attach the appropriate mounting hardware. Refer to the manufacturer's documentation for instructions.

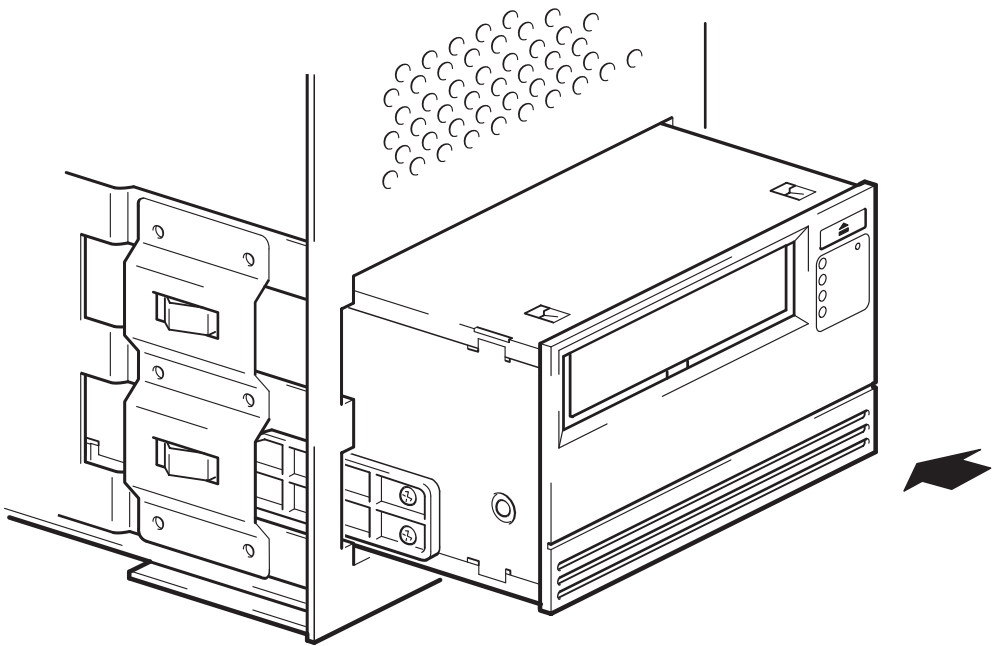

**Figure 6: installing the drive**

## Step 5: Install the drive

- 1 Slide the tape drive into the open bay, aligning the tray or rails with the slots in the bay, as shown in Figure 6.  
If your server does not use mounting hardware, check that the holes in the chassis are aligned with the holes in the side of the tape drive.  
Do not secure the drive with screws at this point because you may have to move the drive to get the cables into place.

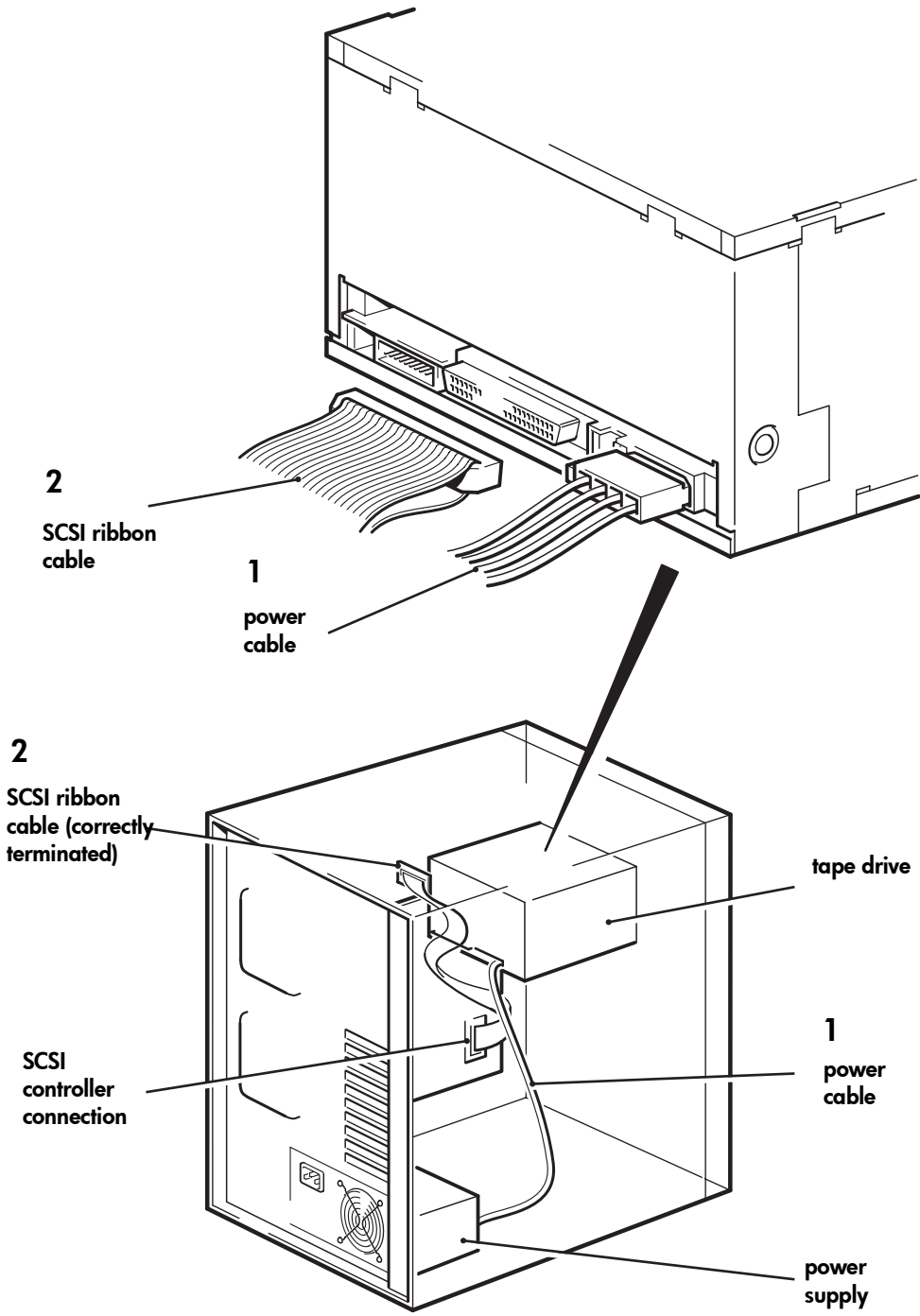

Figure 7: attaching power and SCSI cables

# Step 6: Attach power and SCSI cables

- 1 Attach a spare power cable from the server's internal power supply to the power connector, as shown in Figure 7, item 1.
- 2 Attach a spare connector on the server or HBA's SCSI ribbon cable to the SCSI connector of the drive, as shown in Figure 7, item 2.
- 3 If the drive is the last device on the SCSI chain, make sure that the SCSI cable is terminated correctly

Do **not** daisy-chain Ultrium 960 tape drives. Up to two Ultrium 460 tape drives may be daisy-chained, but is not recommended. If you do so, install your tape drives on an Ultra 320 SCSI bus. Similarly, up to two Ultrium 230 drives may be installed on an Ultra 160 SCSI bus. Do not mix drive families.

**Note** If you attach your drive to a higher-rated SCSI bus, the internal SCSI cable should be of the same specification as the SCSI HBA. For example, if you connect an Ultrium 460 to an Ultra 320 bus, make sure that the internal cable supports Ultra 320.

## Where should the SCSI terminator be?

Termination must be present at two and **ONLY** two positions on the SCSI bus—at the beginning of the SCSI bus and at the end of the SCSI bus. Termination is normally enabled by default on the HBA and most internal SCSI cables have a terminator attached. This will usually be a small, rectangular block of plastic attached to the cable end and marked 'SCSI Terminator'.

Therefore, assuming the HBA is the first device on the bus, you should check that the second terminator is placed after the last device, as shown in Figure 7, item 2.

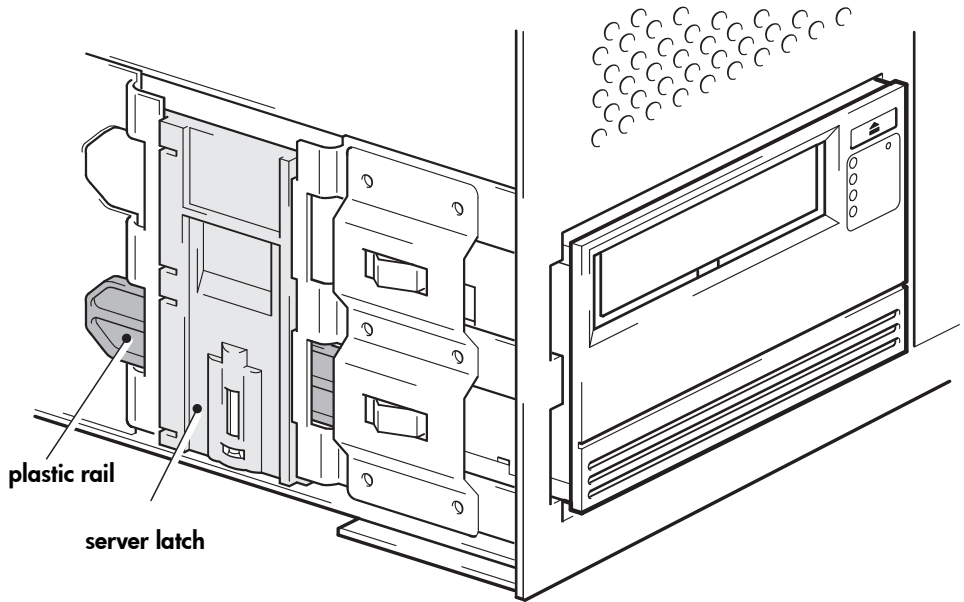

**Figure 8a: securing drive to mounting hardware  
(example shows HP ProLiant ML530)**

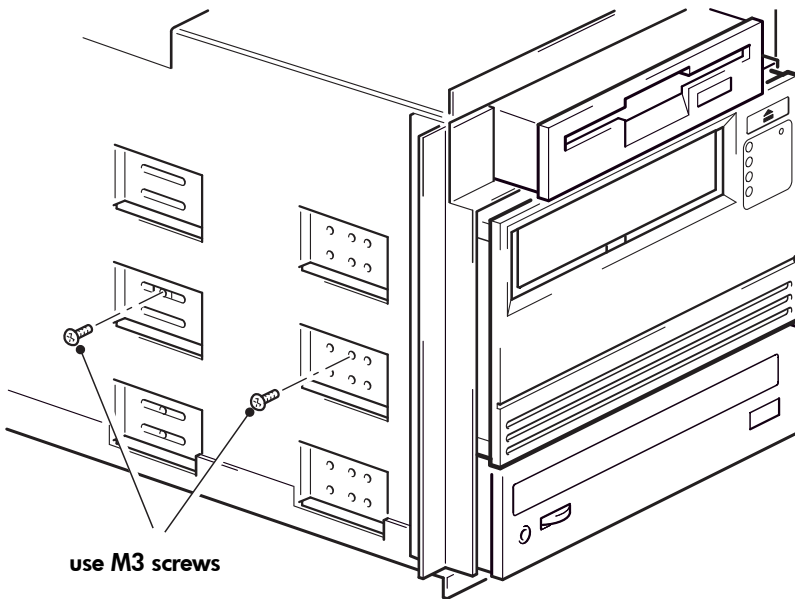

**Figure 8b: securing drive, no mounting hardware  
(example shows HP AlphaServer ES40)**



# Step 7: Secure the drive

**Note** The server latches and side views of your server model may not be exactly the same as shown in the illustrations. Please refer also to your server documentation.

## Mounting hardware used (HP ProLiant)

Ensure that you use the correct mounting rails or locating screws, as described in “Step 4: Attach mounting hardware” on page 15. The server also incorporates a locking mechanism to hold the tape drive in place.

- 1 Push the server latch down to lock the tape drive into position, as shown in Figure 8a.
- 2 Replace the cover on the server.

## No mounting hardware used (HP AlphaServer)

- 1 Use the M3 screws provided with the tape drive to secure it in place. Check that the holes in the chassis are aligned with the holes in the sides of the drive and use a regular Phillips screwdriver to secure the M3 screws, as shown in Figure 8b.
- 2 Replace the cover on the server.



arrow indicates leading  
direction

affix label here

**Figure 9a: loading a cartridge**

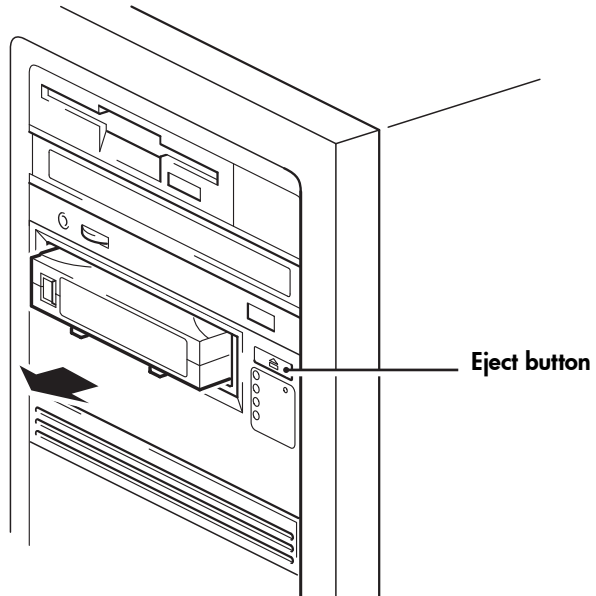

**Figure 9b: unloading a cartridge**

# Step 8: Verify installation

## Check operation

1 Switch on the server. The tape drive will run its hardware self-test, which takes about 5 seconds. If self-test passes, the green Ready LED flashes and then shows steady green. If the test fails, the Drive Error and Tape Error LEDs flash, while the Ready and Clean (or Use Cleaning Cartridge) LEDs are off. This continues until the drive is reset. See “LEDs during self-test” on page 42 for more information about the LEDs.

2 Install drivers and backup software.

On Windows systems, the Windows Hardware Installation wizard is displayed automatically. We recommend that you close the wizard and install the drivers from the link on the *HP StorageWorks Tape* CD-ROM. Insert the CD-ROM, select “install your product” and then select “get drivers”. For all operating systems ensure that you have downloaded any upgrades necessary for your backup application (see page 5).

3 Verify that the tape drive installation was successful.

Select “install your product” from the link on the *HP StorageWorks Tape* CD-ROM and then select “install check”. See page 33 for more information.

The *UNIX Configuration Guide* on the *HP StorageWorks Tape* CD-ROM also includes a verification procedure.

**Note** If you encounter a problem during this verification procedure, turn to “Troubleshooting” on page 37 for help in diagnosing and fixing the problem.

4 Carry out a backup and restore test to check that the drive can write data to tape. Refer to your backup application documentation for specific instructions. Use the blank cartridge supplied with the tape drive. See “Use the correct media” on page 27 for more information about recommended cartridges.

## To load a cartridge

1 Insert the cartridge into the slot in the front of the drive with the white arrow uppermost and facing the drive door. Apply gentle pressure until the drive takes the cartridge and loads it. (See Figure 9a.)

2 The Ready light flashes green while the drive performs its load sequence. When the cartridge is loaded, the Ready light shows steady green.

## To unload a cartridge

**Caution** Never try to remove a cartridge before it is fully ejected and avoid powering off the tape drive while a cartridge is still loaded (because the tape loses tension in the power-off state).

1 Press the Eject button on the front panel. (See Figure 9b.)

2 The drive will complete its current task, rewind the tape to the beginning, and eject the cartridge. The rewind process may take up to 15 minutes. The Ready light will flash to indicate that the unload is still in progress.

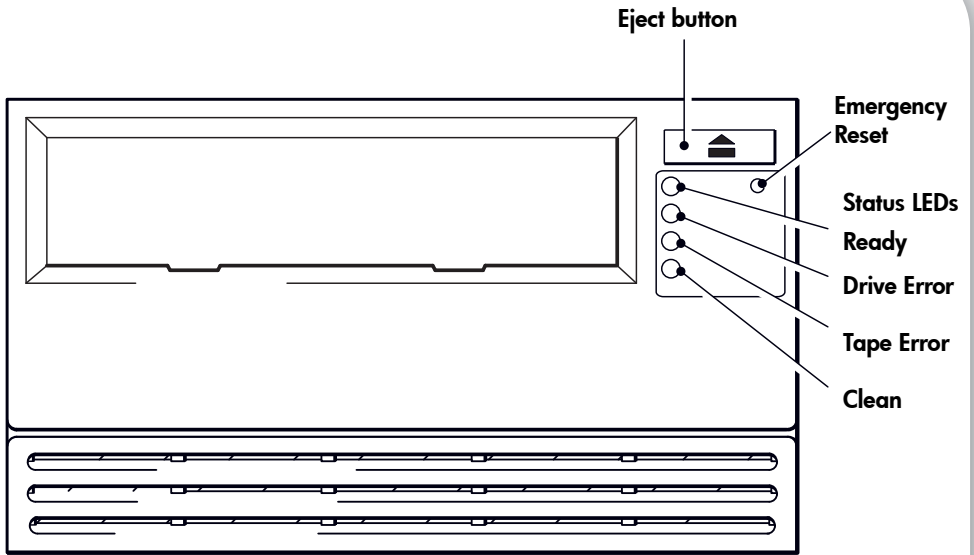

Figure 10a: Ultrium 960 and 460 tape drive controls and indicators

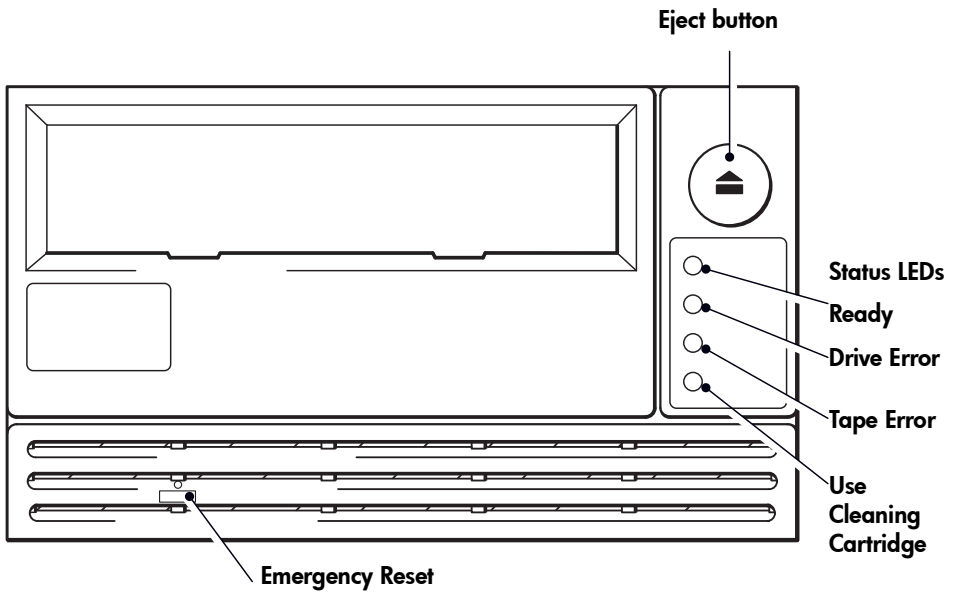

Figure 10b: Ultrium 230 tape drive controls and indicators

# Your HP StorageWorks Ultrium tape drive

Your Ultrium tape drive has four LEDs (light emitting diodes) on the front panel, which indicate drive status. These LEDs provide useful troubleshooting information, see also “Understanding the LEDs” on page 42. See page 23 for more information about using the eject button in normal operation and page 46 for details about force eject and emergency reset.

## Front panel LEDs

There are four LEDs as illustrated in the diagram. (See Figure.)

### Ready (top, green)

- On: the drive is ready for use
- Off: the drive power is off or there was a failure during self-test
- Flashing: the drive is busy
- Flashing repeated pattern: the drive is in OBDR mode

### Drive Error (second, amber)

- Off: no fault has been detected
- Flashing: the drive mechanism has detected a hardware error.

### Tape Error (third, amber)

- Off: no fault has been detected
- Flashing: the tape currently in the drive is faulty. This LED could come on for a number of reasons, but they all relate to the tape being in error in some way, such as unreadable cartridge memory or unsupported tape. Do not use the cartridge; replace it. The LED will go out when a tape load is started.

### Clean (Ultrium 960 and 460) or Use Cleaning Cartridge (Ultrium 230) - bottom, amber

- On: cleaning cartridge in use
- Off: the drive does not require cleaning
- Flashing: the drive needs cleaning

## Accessibility features

The front panel of the HP StorageWorks Ultrium 960 and 460 tape drive has been designed for increased accessibility for persons with disabilities. This includes larger font labeling of the Status LEDs and an Eject button that has been designed for ease of use.

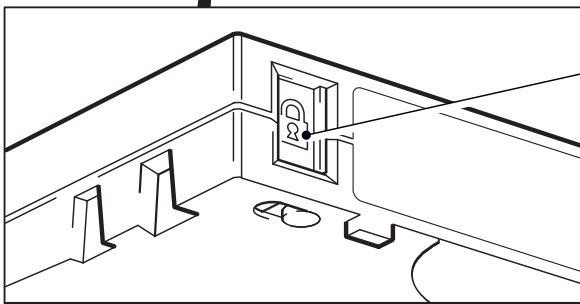

padlock indicates  
cartridge is protected

Figure 11: write-protecting cartridges

# Use the correct media

For best performance we recommend HP branded media. Order online at: [www.hp.com/go/storagemedia/ultrium](http://www.hp.com/go/storagemedia/ultrium).

## Data cartridges

HP StorageWorks Ultrium tape drives use Ultrium tape cartridges. These are single-reel cartridges that match your drive's format and are optimized for high capacity, throughput and reliability. Compatible media can be recognized by the Ultrium logo, which is the same as the logo on the front of your drive. Do not use other format cartridges in your tape drive and do not use Ultrium cartridges in other format tape drives.

For optimum performance always use a data cartridge that matches the specification of your tape drive, (see Table 2). A lower specification will have a lower transfer speed and may not support write activities; a higher specification will not support read or write. We recommend:

- Ultrium 800 GB RW\* (C7973A) and Ultrium 800 GB\* WORM tape cartridges for use with Ultrium 960 tape drives.
- Ultrium 400 GB\* tape cartridges (C7972A) for use with Ultrium 460 tape drives.
- Ultrium 200 GB\* tape cartridges (C7971A) for use with Ultrium 230 tape drives.

\* All values assume 2:1 compression.

	Ultrium 960 drives	Ultrium 460 drives	Ultrium 230 drives
Type of cartridge			
Ultrium 800 GB*	Write and Read	No	No
Ultrium WORM 800 GB*	Write Once, Read Many	No	No
Ultrium 400 GB*	Write and Read	Write and Read	No
Ultrium 200 GB*	Read only	Write and Read	Write and Read

**table 2: Ultrium data cartridge and HP StorageWorks Ultrium tape drive compatibility**

## WORM data cartridges

The HP Ultrium StorageWorks 960 tape drive includes support for both rewriteable and WORM data cartridges. Write-Once, Read-Many (WORM) data cartridges provide for an enhanced level of data security against accidental or malicious alteration of data on the tape cartridge. The WORM data cartridge can be appended to maximize the full capacity of the tape cartridge, but the user will be unable to erase or overwrite data on the cartridge. WORM data cartridges are clearly identified by their distinctive, two-tone cartridge color.

To check whether your backup or archive software application supports WORM cartridges, refer to the following web site: [www.hp.com/go/connect](http://www.hp.com/go/connect).

For information on how your HP Ultrium StorageWorks 960 tape drive and WORM cartridge can help your business meet Information Lifecycle Management and regulatory compliance requirements, please refer to the HP Business Support Center at: [www.hp.com](http://www.hp.com).

## Write-protecting cartridges

If you want to protect the data on a cartridge from being altered or overwritten, you can write-protect the cartridge.

Always remove the cartridge from the tape drive before you change the write protection.

- To write-protect a cartridge, slide the red tab by the label area on the rear face of the cartridge to close the hole. Note the padlock on the tab that indicates that the cartridge is protected.
- To write-enable a cartridge, slide the red tab back so that the hole is open before loading it into the drive. Figure 11 illustrates the location of the write-protect tab.

Write-protection will not prevent a cartridge being erased by bulk-erasure or degaussing. **Do not bulk erase Ultrium format cartridges.** This will destroy pre-recorded servo information and make the cartridge unusable.

## Cleaning cartridges

You must use Ultrium cleaning cartridges with HP StorageWorks Ultrium tape drives, as other cleaning cartridges will not load and run. We recommend the HP Ultrium universal cleaning cartridge (see table 3). Unlike some earlier Generation 1 Ultrium cleaning cartridges, the orange-colored Ultrium universal cleaning cartridge is designed to work with any Ultrium-compliant drive. Do not use other format cartridges in your tape drive and do not use Ultrium cartridges in other format tape drives.

Type of cartridge	Recommended cartridge	Other options
Cleaning	<b>HP Ultrium universal cleaning cartridge C7978A (Orange)</b>	HP Ultrium 1 cartridge C7979A (Blue). Do not use other Ultrium 1 (IBM/Seagate) cartridges.

**table 3: cleaning cartridge compatibility**

### To clean the tape drive

HP StorageWorks Ultrium tape drives do not require regular cleaning. An Ultrium universal cleaning cartridge is supplied with each tape drive and should only be used when the orange Clean (Ultrium 960 and 460) or Use Cleaning Cartridge (Ultrium 230) LED is flashing.

- 1 Insert the Ultrium universal cleaning cartridge.
- 2 The drive will carry out its cleaning cycle and eject the cartridge on completion (which can take up to 5 minutes). During the cleaning cycle the orange Clean (Ultrium 960 and 460) or Use Cleaning Cartridge (Ultrium 230) LED will be on solidly and the green Ready LED will flash.

Each HP Ultrium universal cleaning cartridge cleaning cartridge can be used up to 50 times with Ultrium 960 and Ultrium 460 tape drives, and up to 15 times with Ultrium 230 tape drives. (HP Ultrium 1 cleaning cartridges can only be used up to 15 times with any tape drive.) If the cleaning cartridge is ejected immediately with the Tape Error LED on, it has expired.

## Caring for cartridges

It is important that you look after your HP media and adhere to the recommended guidelines. See "Looking after cartridges" on page 46.



# Register your tape drive

Once you have installed and tested your HP StorageWorks Ultrium tape drive, please take a few minutes to register your product. You can register via the web at [www.register.hp.com](http://www.register.hp.com).

To ensure your registration is complete, there are a number of questions on the electronic form that are mandatory. Other questions are optional. However, the more you feel able to complete, the better we can meet your needs.

**Note** HP and its subsidiaries are committed to respecting and protecting your privacy. For further information, please visit our World Wide Web site ([www.hp.com](http://www.hp.com)) and click on Privacy Statement.

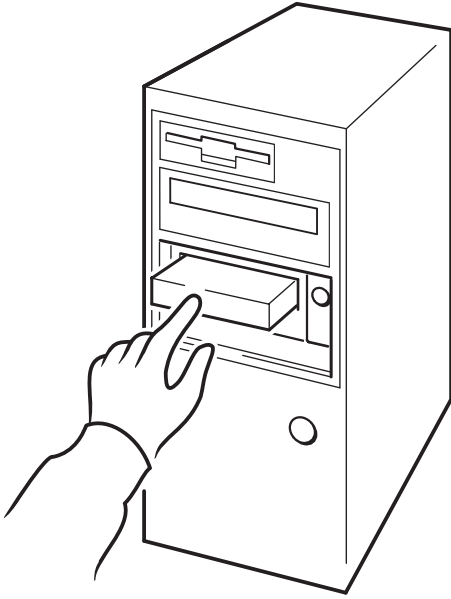

Figure 12a: using HP OBDR, step 1



Figure 12b: using HP OBDR, step 2

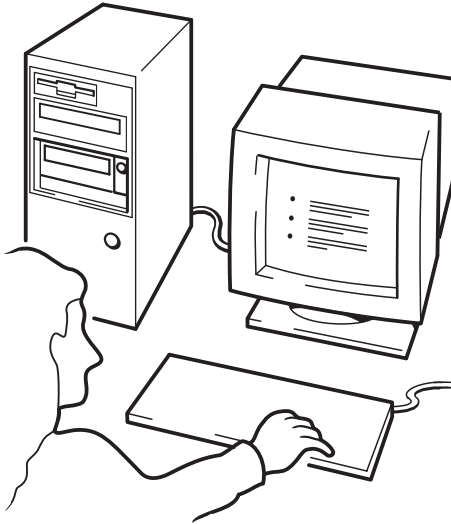

Figure 12c: using HP OBDR, step 3

# Using HP OBDR

## Compatibility

HP One-Button Disaster Recovery is a standard feature on all HP StorageWorks Ultrium tape drives. However, it can only be used with specific configurations and, although it can be used in a network environment, will only recover the server to which the tape drive is directly connected.

To check whether your system (hardware, operating system and backup software) is OBDR-compatible, please refer to our World Wide Web site [www.hp.com/go/connect](http://www.hp.com/go/connect).

For more specific information concerning the benefits of OBDR and the latest new features please refer to our World Wide Web site [www.hp.com/go/obdr](http://www.hp.com/go/obdr).

**Note** HP OBDR is not applicable to HP-UX and other non-Intel UNIX operating systems, and it is not compatible with Intel-based Solaris systems. HP OBDR is supported on a server with a RAID controller, if the tape drive is connected directly to a host bus adapter (HBA).

If your system does not support HP One-Button Disaster Recovery, you can still use your tape drive normally to back up and restore data. However, you must remember to create a separate set of emergency recovery disks for your operating system whenever you change your system configuration.

## What does HP OBDR do?

Using just the tape drive and the most recent backup cartridge HP OBDR allows you to recover from the following types of system disaster:

- Hard disk failures, as long as the replacement hard disk is the same size or larger than the original and uses the same interface (for example, replace a SCSI hard disk with another SCSI disk)
- Hardware failures where the server is replaced by an **identical** component
- File corruption because of an operating system error
- File corruption because of an application software error
- Viruses that prevent you from booting your system correctly
- User errors that stop you from booting your system correctly

When you run HP One-Button Disaster Recovery, your tape drive goes through the following sequence:

- 1 It goes into a special disaster recovery mode that enables it to restore your operating system and reboot. It acts like a bootable CD-ROM. (Your system's ability to boot from CD-ROM is normally enabled by default. If you have changed this setting, you will need to enable it again. Refer to your system BIOS manual for further details.)
- 2 It returns to normal tape drive mode and restores the data.

## Remote disaster recovery (ProLiant servers only)

The HP Remote Insight Lights-Out Edition (RILOE) on ProLiant servers gives the IT Administrator the ability to completely recover a failed server at a remote location without physically traveling to where the server resides. The on-site, non-technical person need only insert the bootable cartridge into the tape drive, when asked to do so by the administrator.

Refer to the HP OBDR web site at [www.hp.com/go/obdr](http://www.hp.com/go/obdr) for more information about using this feature and compatibility.

## Testing for compatibility

We recommend that you perform a full disaster recovery immediately after installation—if possible, onto a blank hard disk. If you do not have a blank hard disk and do not want to overwrite your system, you can safely cancel the disaster recovery process at step 3 in the following procedure.

Refer to our connectivity web site ([www.hp.com/go/connect](http://www.hp.com/go/connect)) for more information about suitable backup applications.

## Running HP OBDR

HP OBDR can only be used with backup applications that support one-button disaster recovery and methods of operating OBDR will vary between different software companies.

Check our World Wide Web site ([www.hp.com/go/obdr](http://www.hp.com/go/obdr)) for the latest information about firmware upgrades and troubleshooting before you use HP OBDR.

- 1 Insert the latest bootable cartridge in the tape drive (see Figure 12a). The cartridge must be written by a backup application that writes data to tape in CD-ROM format.
- 2 Hold down the eject button. Keeping the eject button pressed down, power on your server (see Figure 12b). This activates the HP One-Button Disaster Recovery process. Release the button as soon as the Ready LED on the front panel flashes in the OBDR sequence. This is a repeated pattern of: flashing-steady on-flashing.

### Keyboard shortcut for HP ProLiant servers

There is no need to press the Eject button. Just power on your server and press the [F8] Function key during the Power On Self Test (POST). This invokes OBDR to restore your system. For more information and specific instructions please refer to our World Wide Web site at [www.hp.com/go/obdr](http://www.hp.com/go/obdr).

- 3 Follow the on-screen instructions to set up the operating system (see Figure 12c). (These will vary depending upon the backup software.) Normally, you can accept the default response to all the prompts, for example, just press <Enter>.
- 4 The LEDs will flash in OBDR mode (as described in step 2) while the tape drive restores your operating system to a state, where it can run a normal data restore.
- 5 Once the operating system has been set up and rebooted, the Ready LED display on the tape drive changes to constant green and you can remove the backup cartridge, if you wish. You are now ready to run a normal data restore. Follow the normal process for your restore application.

### If restore fails

If the restore fails for any reason, refer to our World Wide Web site ([www.hp.com/go/obdr](http://www.hp.com/go/obdr)) for detailed troubleshooting information.

# Diagnostic tools

## HP Library & Tape Tools

HP StorageWorks Library & Tape Tools is the recommended diagnostic and support tool for your HP tape storage product. It is available on the CD shipped with your product or as a free download from the HP web site. It is supported on nearly all major operating systems.

See [www.hp.com/support/tapetools](http://www.hp.com/support/tapetools) for compatibility information, updates and the latest version of the tool.

### Checking drive installation with Library & Tape Tools

The tape drivers must already be installed to run this check. You will also need to provide a tape cartridge that can be written to during the test.

- 1 From the HP StorageWorks CD, select "install your product" and then "install check". This will run Library & Tape Tools directly from the CD (no installation on the server) in a special mode for installation checking.
- 2 Select the appropriate tests to verify the installation of your drive.
  - Verify device connectivity
  - Verify configuration (bus and driver configuration)
  - Verify drive health (writing and reading to a test cartridge)
  - Verify drive performance (data rates to the drive)
  - Verify system performance (data rates from the disk subsystem)
  - Verify drive cooling
- 3 At the end of the test you will be given a summary of the test results and recommendations to resolve any issues found.

### Troubleshooting with Library & Tape Tools

- 1 From the HP StorageWorks CD, select "troubleshoot".

This will allow you to run Library & Tape Tools in standard mode, either directly from the CD (no installation on the server) or as an installation on your server. HP recommends installation of Library & Tape Tools, so that it can be quickly accessed at any time. HP Support will also request that you use Library & Tape Tools should you need to contact them in the future, so it is a good idea to have it installed.
- 2 When Library & Tape Tools is first run, it will scan for HP tape drives and libraries on your system and ask you to select the one to work with. At this time you can see the HBA configuration of your server, how your devices are connected and the SCSI IDs of those devices.
- 3 Once you have selected your device you have a number of choices for troubleshooting.
  - Device identification: shows part number, serial number and information about any cartridge loaded
  - Firmware upgrade: allows you to locate and upgrade to the latest firmware. You will need

to be connected to the internet for this.

- **Run tests:** allows you to run proactive tests on your drive, such as the drive assessment test, which will verify the functionality of your drive in around 20 minutes. HP recommends running this test before calling HP Support. You will need to provide a 'trusted' cartridge that can be written to during this test.
- **Generate a support ticket:** this is a full dump of the drive logs along with interpretation and is used by HP Support to learn about the condition of your drive. Most useful is the device analysis section which is the output from approximately 20 rules forming a comprehensive analysis of the health of your drive. These rules may give advice such as cleaning the head or trying a different tape if issues are found. The support ticket can be sent to HP Support for further analysis.
- **Run the performance tests:** the tests to measure the write/read performance of your tape drive and the data generation rates of your disk subsystem are also integrated into Library & Tape Tools. Use these tests to find the performance bottleneck in your system.

## Performance Assessment Tools

For maximum performance your disk sub-system needs to be able to supply data at 80 MB/second (uncompressed) for Ultrium 960 drives, 30 MB/second (uncompressed) for Ultrium 460 drives and 15 MB/second (uncompressed) for Ultrium 230 drives.

You can use our free, standalone performance assessment tools to check tape performance and test whether your disk subsystem can supply data at the maximum transfer rate.

The tools are located online at [www.hp.com/support/pat](http://www.hp.com/support/pat) along with a complete guide to understanding the performance needs of your backup system and recommendations on finding and fixing performance issues. In nearly all cases when performance is not as expected, it is the data rates of the disk subsystem that cause the bottleneck. Please follow the guide and try the tools before calling HP Support.

Note that the performance tools are also integrated into HP Library & Tape Tools, which is available both online ([www.hp.com/support/tapetools](http://www.hp.com/support/tapetools)) and on the CD-ROM supplied with your tape drive.

# Optimizing performance

We strongly recommend that you check the information on our web site at [www.hp.com/support/pat](http://www.hp.com/support/pat). This contains detailed support information that will enable you to identify bottlenecks and take full advantage of the performance capabilities of the Ultrium family of tape drives.

Various factors can affect data throughput, particularly in a network environment or if the drive is not on a dedicated SCSI bus. If your tape drive is not performing as well as expected—for example, if backup windows are longer than expected—consider the points in this section before contacting HP Support at [www.hp.com/support](http://www.hp.com/support).

## Is the tape drive on a dedicated SCSI bus?

We recommend that the tape drive is the only device on the SCSI bus. If it is not, ensure other devices are LVD-compliant. If they are single-ended, the bus will switch to single-ended mode with a lower transfer speed. There will also be restrictions on cable length.

Auto termination powers down when the tape drive powers down. This can cause a problem, if there are other devices on the SCSI bus.

## Can your system deliver the required performance?

- The Ultrium 960 tape drive can write uncompressed data at up to 80 MB/s (288 GB/hour) or compressed data at up to 160 MB/s (576 GB/hour), assuming 2:1 compression. These drives are extremely high-performance devices. If performance is not meeting expectations, the problem almost certainly lies with the system architecture.
- The Ultrium 460 tape drive can write uncompressed data at up to 30 MB/s (108 GB/hour) or compressed data at up to 60 MB/s (216 GB/hour), assuming 2:1 compression.
- The Ultrium 230 tape drive can write uncompressed data at up to 15 MB/s (54 GB/hour) or compressed data at up to 30 MB/s (108 GB/hour), assuming 2:1 compression.

To get this performance it is essential that your whole system can deliver this performance. In most cases, the backup application will provide details of the average time taken at the end of the backup.

Typical areas where bottlenecks can occur are:

- **Disk subsystem**

A single spindle disk will not be able to deliver good data throughput for an Ultrium 960, at any compression ratio. To maximize the capability of your Ultrium 960 drive, utilize aggregated disk sources (RAID) with multiple disk spindles.

A single spindle disk may well be sufficient for an Ultrium 460 or 230 depending on your data's compressibility. Best practice to ensure good throughput is to utilize multiple disk spindles or data sources.

- **System architecture**

Be aware of the architecture of your data protection environment; multiple clients backed up over a network may mean you are unable to take advantage of the Ultrium 960 because the Ethernet infrastructure connecting such systems may limit performance.

For Ultrium 460 and 230 drives, the aggregation of multiple client sources over a network remains a good way of delivering good performance. Some enterprise class backup applications can be made to interleave data from multiple sources, such as clients or disks,

to keep the tape drive working at optimum performance.

- **Tape media type**

The data cartridge should match the specification of the tape drive. A lower specification will have a lower transfer speed (see "Data cartridges" on page 27). Use Ultrium 800 GB or Ultrium 800 GB WORM cartridges with Ultrium 960 tape drives, Ultrium 400 GB cartridges with Ultrium 460 tape drives and Ultrium 200 GB cartridges with Ultrium 230 tape drives.

- **Data and file types**

The type of data being backed up or restored can affect performance. Typically, small files incur greater overhead in processing and access than large files. Equally, data that is not compressible will always limit the speed at which the drive can write/read data. You will achieve no more than native rates with uncompressible data.

Examples of files that compress well are plain text files, spreadsheets; those that compress poorly are those that are either compressed as part of their format (such as, JPEG photographic files) or stored as compressed (such as, .ZIP files or .gz/.Z files on Unix platforms).



# Troubleshooting

The first step in problem-solving is establishing whether the problem lies with the cartridge, the drive, the host server and its connections, or with the way the system is being operated.

Most modern SCSI host bus adapters locate and display attached devices when the system is booting up. On Windows systems, if you swap or connect a product when your system is running, you will need to reboot the system. IA32 systems also usually need to be rebooted. UNIX systems may have pluggable drivers, which allow drives to be attached to a running system and detected without rebooting.

If the device is not detected on boot up, there is probably a problem with the physical hardware: cables, termination, connections, power or the host bus adapter itself. If the device is displayed during boot up but cannot be found in the operating system, this is more likely to be a software problem.

- If you encounter a problem during installation and need further clarification, refer to the “Problems encountered during installation” section on page 38.
- If a problem arises during testing after you have installed the drive, refer to the symptom-based section “Testing after installation” on page 40.
- For more information about LED sequences, refer to “Understanding the LEDs” on page 42.
- For information about cartridges, refer to “Problems with cartridges” on page 46.

Most users can use HP Library & Tape Tools to help them diagnose problems, see page 33.

## Web troubleshooting guide

Please refer also to the detailed troubleshooting guide on the web at [www.hp.com/go/support](http://www.hp.com/go/support). This contains the most comprehensive and up-to-date troubleshooting information.

## Problems encountered during installation

### *Unpacking*

Description	Further information
Some parts appear to be missing or damaged.	Contact your vendor if any parts need replacing.

### *The screws or mounting hardware are not suitable for the server*

Description	Further information
Additional parts may be required for fitting the tape drive into the server.	The HP StorageWorks Ultrium internal tape drive will fit into most servers without the need for additional hardware other than that originally shipped with your system. If additional parts are required, or the original parts have been lost, contact your server vendor. See "Step 4: Attach mounting hardware" on page 15.

### *It is unclear which SCSI ID to use*

Description	Further information
It is uncertain which ID numbers are available.	Use HP Library & Tape Tools (see page 33) to provide information on your current SCSI settings. The HP StorageWorks Ultrium drive has its SCSI ID set to 3 by default. This should be left unchanged unless this number is already in use. Full instructions on how to change the SCSI ID are given on page 11.

### *How should the SCSI bus be configured?*

Description	Further information
Correct configuration of the SCSI bus with multiple drives can be a complex area and more help may be required. Daisy chaining devices is not generally recommended.	Refer also to the "SCSI Configuration" section in the online User's Guide on the <i>HP StorageWorks Tape</i> CD-ROM.

### *How should the SCSI bus be terminated?*

Description	Further information
It is unclear if the bus is already terminated or where an additional terminator should be placed.	Both ends of a SCSI bus must be terminated. Typically, when connecting an internal drive to the ribbon cable already inside your server then both the host bus adapter and the end of the ribbon cable will already be terminated and no further action is required. Refer also to the "SCSI Configuration" section in the online User's Guide on the <i>HP StorageWorks Tape</i> CD-ROM.

### ***Is the correct SCSI host bus adapter installed?***

<b>Description</b>	<b>Further information</b>
The server already has a SCSI host bus adapter but it is difficult to determine what type it is.	If your server is in its original configuration (no SCSI adapters have been added or removed) then use <a href="http://www.hp.com/go/connect">www.hp.com/go/connect</a> to check the compatibility of your system. You can also check the SCSI configuration from the boot-up screen or from the Windows Control Panel, or by using HP Library & Tape Tools (see page 33).
The server may not have a SCSI host bus adapter installed.	Use HP Library & Tape Tools (see page 33) to check whether you have a SCSI host adapter on your system. If not, you will need to purchase one.

### ***Do drivers need to be installed and, if so, which ones***

<b>Description</b>	<b>Further information</b>
It is unclear whether there is a need to install drivers onto the system and more help is required.	Detailed information specific to your system can be found on the <a href="http://www.hp.com/go/connect">www.hp.com/go/connect</a> web site. For support on Windows operating systems, drivers can be obtained from the <i>HP StorageWorks Tape</i> CD-ROM or from <a href="http://www.hp.com/support/ultrium">www.hp.com/support/ultrium</a> . For support on UNIX systems, see the UNIX Configuration section in the online User's Guide on the <i>HP StorageWorks Tape</i> CD-ROM. (Backup software that states support for HP StorageWorks Ultrium tape drives also provides the required drivers.)
The required drivers do not appear to be available.	Future drivers will be provided via the support web site when they become available.

## Testing after installation

Remember that the system recognizes devices during boot-up. If you swap or connect a product when your system is running, you will need to reboot the system. Rebooting the system will reset devices and will often resolve problems. It is good practice to reboot every time you add a driver or install firmware.

**Caution** Never power off the drive while a cartridge is still loaded or during a firmware upgrade.

### *The server does not reboot after installation*

Possible reason	Recommended action
You have connected the tape drive to an existing SCSI bus that has other devices connected to it and the SCSI address of your HP StorageWorks Ultrium drive is identical to the address used by another device.	Make sure that each device on the SCSI bus has a unique ID. We recommend that the HP StorageWorks Ultrium tape drive is connected to a dedicated host bus adapter. Do not connect the drive to a disk RAID controller as this is not supported.
You have installed an additional SCSI host bus adapter and its resources are clashing with an existing adapter.	Remove the new host bus adapter and check the server documentation.
You have disconnected the power or SCSI cable from the server's boot disk during the drive installation process.	Check that the cables to all devices are firmly connected.

### *The server boots but does not recognize the tape drive*

Possible reason	Recommended action
The power or SCSI cable is not connected properly.	Check that the cables to the tape drive are firmly connected. Ensure that the SCSI cable is LVDS-compliant and does not have any bent pins. Replace, if necessary.
The SCSI bus is not terminated correctly.	Check that the SCSI bus is actively terminated. (Refer also to the documentation for your SCSI controller and any other SCSI devices you may have.)
The tape drive's SCSI ID address is not unique.	Make sure that each device connected to the SCSI controller has a unique SCSI ID. Remember that 7 is normally reserved for the host bus adapter. (You can run HP Library & Tape Tools to check the SCSI IDs of each device attached to the SCSI bus, see page 33.)

### ***The application does not recognize the tape drive***

<b>Possible reason</b>	<b>Recommended action</b>
The application does not support the tape drive.	Use HP Library & Tape Tools to check that the drive is installed properly. Refer to our World Wide Web site ( <a href="http://www.hp.com/go/connect">www.hp.com/go/connect</a> ) for details of software applications that support the HP StorageWorks Ultrium tape drive. Load any service packs as necessary.
Some applications require drivers to be loaded.	Check that the correct SCSI and tape drive drivers are installed. Consult the software application's installation notes for details.

### ***The drive does not work***

<b>Possible reason</b>	<b>Recommended action</b>
If the drive does not power up (all LEDs are off), the power cable may not be connected to the drive properly.	Check the power cable connection and replace the cable if necessary. You can use the power cable from your monitor or another device to check that the connection is working. If the power supply is present and all LEDs remain off, call for assistance.
If the self-test fails (see "LEDs during self-test" on page 42), there may be a hardware or firmware failure.	If there is a cartridge in the drive, remove it. Reset or power down the drive and power it up again. If the self-test still fails, call for assistance.

### ***Cartridge-related problems***

Please see "Problems with cartridges" on page 46.

# Understanding the LEDs

## LEDs during self-test



**Ultrium 960 and 460**

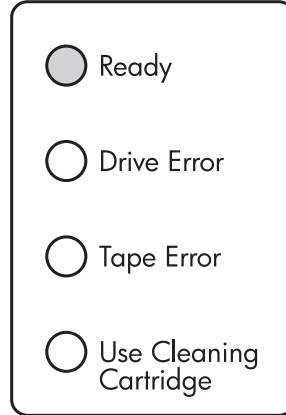

**Ultrium 230**

Your Ultrium tape drive has four LEDs (light emitting diodes) on the front panel, which indicate drive status, and two LEDs on the rear panel. These LEDs provide useful troubleshooting information.

The tape drive performs a power on self-test whenever power is applied or the drive is reset. The test takes about 5 seconds. The LED sequence for each drive is described in the following table.

Ultrium 960 and 460	Ultrium 230
<ol style="list-style-type: none"> <li><b>1</b> The green Ready light flashes several times and then remains on if self-test passes. All other LEDs remain off.</li> <li><b>2</b> If the self-test fails, the Drive Error and Tape Error LEDs flash, while the Ready and Clean LEDs are off. This continues until the drive is reset.</li> </ol>	<ol style="list-style-type: none"> <li><b>1</b> The green Ready light and the three orange lights for the other LEDs flash briefly and then go out.</li> <li><b>2</b> The green Ready LED flashes and then remains on if self-test passes.</li> <li><b>3</b> If the self-test fails, the Drive Error and Tape Error LEDs flash, while the Ready and Use Cleaning Cartridge LEDs are off. This continues until the drive is reset.</li> </ol>

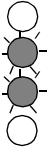

**table 4: self-test LED sequence**





**Note** The LED labels are identical apart from the bottom one, which is Clean on the Ultrium 960 and 460 and Use Cleaning Cartridge on the Ultrium 230. All references to Clean in the following table should, therefore, read Use Cleaning Cartridge if you have an Ultrium 230 drive.

## Using the LEDs for troubleshooting

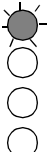
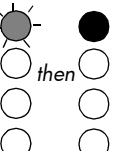
If you cannot resolve a problem, contact customer service at [www.hp.com/support](http://www.hp.com/support).

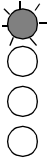
Use the following table to interpret the front panel LED sequences and the appropriate action to take, if any.

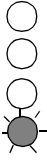
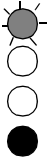
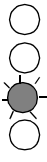
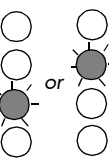
LED Sequence	Cause	Action required
	<p><i>All LEDs OFF.</i></p> <p>Drive may not have power, may be faulty or may have been power cycled or reset during a firmware upgrade.</p>	<p>Make sure the drive is switched on. The power on/off switch incorporates a green LED.</p> <p>If this is not on, check the power cable connection and replace the cable if necessary. You can use the power cable from your monitor or another device to check that the connection is working.</p> <p>If the power supply is present and all LEDs remain off, press emergency reset (see page 46) or power cycle the drive. If it still fails, call for service.</p>
	<p><i>Ready and Clean OFF.</i></p> <p><i>Drive Error and Tape Error FLASHING.</i></p> <p>The drive has failed to execute power-on self test (POST).</p>	<p>Power cycle or reset the drive (see page 46).</p> <p>If the error condition reappears, call for service.</p>
	<p><i>Ready is ON.</i></p> <p>The drive is ready for operation.</p>	<p>None. This is normal.</p>
	<p><i>Ready is FLASHING.</i></p> <p>The drive is carrying out a normal activity (read, write).</p>	<p>None.</p> <p>If the drive is upgrading firmware, do not reset or power cycle it.</p>
	<p><i>Ready is FLASHING-steady ON-FLASHING</i></p>	<p>The drive is in OBDR mode.</p> <p>See "Running HP OBDR" on page 32 for further details.</p>

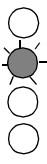
LED Sequence	Cause	Action required
	<p><i>Ready is FLASHING fast.</i></p> <p>The drive is downloading firmware.</p>	<p>None.</p> <p>Do not reset or power cycle the drive.</p>
	<p><i>Ready is OFF, others are ON.</i></p> <p>Firmware is being reprogrammed.</p>	<p>None.</p> <p>Do not reset or power cycle the drive.</p>
	<p><i>Clean is FLASHING.</i></p> <p>The drive requires cleaning.</p>	<p>Load the Ultrium cleaning cartridge. See page 28 for supported cartridges and instructions.</p> <p>If the Clean LED is still flashing when you load a new or known data cartridge after cleaning, call for service.</p>
	<p><i>Ready is FLASHING and Clean is ON.</i></p> <p>Cleaning is in progress.</p>	<p>None. The cleaning cartridge will eject on completion.</p> <p>The cleaning cycle can take up to 5 minutes to complete.</p>
	<p><i>Tape Error is FLASHING.</i></p> <p>The drive believes the current tape or the tape just ejected is faulty.</p>	<p>Unload the tape cartridge. Make sure that you are using the correct format cartridge; an Ultrium data cartridge or Ultrium Universal cleaning cartridge. (See page 28.)</p> <p>Reload the cartridge. If the Tape Error LED still flashes or starts flashing during the next backup, load a new or known, good cartridge.</p> <p>If the Tape Error LED is now off, discard the 'suspect' tape cartridge. If it is still on, call for service.</p>
 <p>or</p> 	<p><i>The tape is ejected immediately and Tape Error is FLASHING, or Drive Error FLASHES on unloading tape.</i></p> <p>The tape cartridge memory (CM) may be faulty.</p>	<p>Write-protect the cartridge by sliding the red switch on the tape cartridge. The tape can be loaded and the data read. Once the data is recovered, the cartridge must be discarded.</p>
	<p><i>Drive Error FLASHING.</i></p> <p>The drive mechanism has detected an error.</p>	<p>Load a new cartridge. If the error persists, power cycle or reset the drive.</p> <p>If the Drive Error LED remains on, call for service.</p>

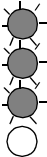
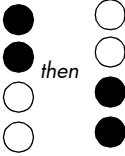

LED Sequence	Cause	Action required
	<p><i>Drive Error, Tape Error and Ready FLASHING.</i></p> <p>There is a firmware download problem.</p>	<p>Insert a cartridge to clear the LED sequence. If the condition persists, call for service.</p>
	<p><i>Drive Error and Ready ON with Tape Error and Clean OFF. Sequence alternates repeatedly.</i></p> <p>The drive has a firmware error.</p>	<p>Power cycle or reset the drive.</p> <p>Upgrade the firmware. If the condition persists, call for service.</p>

# Problems with cartridges

If you experience any problems using HP branded cartridges, check:

- You are using the correct cartridge for your tape drive, see “Use the correct media” on page 27.
- The cartridge case is intact and that it contains no splits, cracks or damage.
- The cartridge has been stored at the correct temperature and humidity.
- The write-protect switch is fully operational. It should move from side to side with a positive click.
- The World Wide Web site for more detailed troubleshooting information: [www.hp.com/support/ultrium](http://www.hp.com/support/ultrium).

## Looking after cartridges

- Do not touch the tape media.
- Do not attempt to clean the tape path or tape guides inside the cartridge.
- Do not leave cartridges in the drive. The tape loses tension in the power-off state, which can lead to problems, particularly if the drive has been moved.
- Do not leave cartridges in excessively dry or humid conditions.
- Do not leave cartridges in direct sunlight or in places where magnetic fields are present (for example, under telephones, next to monitors or near transformers).
- Do not drop cartridges or handle them roughly.
- Stick labels onto the label area only.
- Do not bulk erase Ultrium format cartridges.

## Operating and storage environment

To prevent condensation and for long life, the cartridge should only be operated or stored as follows:

- Day-to-day storage (in plastic container): 16° C to 32° C (60° F to 90° F)
- Operation: 10° C to 45° C (50° F to 113° F)
- Humidity: 20% to 80% Relative Humidity

Tapes intended for archiving data should be stored in the plastic containers, at temperatures between 5°C and 23°C (41°F and 73°F) and 10% to 50% relative humidity. Wet bulb temperature should not exceed 26°C (78°F).

We also recommend storing cartridges on their side.

## Cartridge is jammed

If the cartridge is jammed or the backup application is unable to eject it, you can force eject the cartridge. It is good practice to run Library & Tape Tools to diagnose the problem. If the failure occurs regularly, contact customer service at [www.hp.com/support](http://www.hp.com/support).

- 1 Press and hold the Eject button on the front of the tape drive for 10 seconds.
- 2 Wait for the cartridge to be ejected. This process may take up to 15 minutes (the maximum

rewind time). It is important that you allow sufficient time for the drive to complete this process. If you interrupt it, you may damage the media or the tape drive.

- 3 If the cartridge is still jammed, press the emergency reset button as shown on page 25. (Use the tip of a paperclip to press the button.)
- 4 Wait for the drive to reset and get back to the loaded position. The Ready light stops flashing. This process may take up to 15 minutes (the maximum rewind time) to complete.
- 5 Press and hold the Eject button for 10 seconds.  
If the cartridge is still jammed, the tape drive has failed. Contact customer service at [www.hp.com/support](http://www.hp.com/support).

## The drive will not accept cartridge (or ejects it immediately)

The cartridge is probably incompatible, check Table 2, "Ultrium data cartridge and HP StorageWorks Ultrium tape drive compatibility," on page 27 and Table 3, "cleaning cartridge compatibility," on page 28. If the cartridge is compatible, it may have been damaged, for example it may have been dropped, the cartridge memory may be corrupted or the drive may have a fault.

**Caution** Never force the cartridge into the drive.

- 1 Check that the drive has power (the power cable is properly connected and the ready LED is on).
- 2 Check that you are using the correct media. Only use Ultrium media, we recommend the HP Ultrium 800 GB cartridge or 800 GB WORM cartridge for Ultrium 960 drives, the HP Ultrium 400 GB cartridge for Ultrium 460 drives and the HP Ultrium 200 GB cartridge for Ultrium 230 drives (see page 27).
- 3 Make sure that you have loaded the cartridge with the correct orientation (see "To load a cartridge" on page 23).
- 4 Check for damage to your media (to the cartridge case, leader pin or cartridge teeth) and discard it if it is damaged. See the troubleshooting section of the User's Guide on the *HP StorageWorks Tape* CD-ROM for more information about checking the leader pin and cartridge teeth.
- 5 Use a new or known, good piece of media and see if it loads. If it does, the original cartridge is faulty and should be discarded.
- 6 Check if another Ultrium drive will accept the cartridge. If it does, the original drive may be faulty. Before calling customer service, please check that the tape drive is responding and that it can be seen on the SCSI bus. Most users can use HP Library & Tape Tools, see page 33.

# Other sources of information

You will also find troubleshooting information and contact details on the *HP StorageWorks Tape* CD-ROM and the HP web site. In particular:

- The online User's Guide on the *HP StorageWorks Tape* CD-ROM contains troubleshooting information.
- The HP support web site contains a link to [www.hp.com/support/ultrium](http://www.hp.com/support/ultrium) that takes you to HP's Customer Care web site for a wide range of up-to-date information about your product.
- The HP web site at [www.hp.com/go/connect](http://www.hp.com/go/connect) provides details of recommended products and configurations.
- The HP web site at [www.hp.com/support/tapetools](http://www.hp.com/support/tapetools) provides compatibility information about HP Library & Tapetools, updates and the latest version of the tool.
- The HP web site at [www.hp.com/support/pat](http://www.hp.com/support/pat) provides access to our free, standalone, performance assessment tools to check tape performance and test whether your disk sub-system can supply data at the optimum transfer rate.
- The HP web site at [www.hp.com/go/obdr](http://www.hp.com/go/obdr) provides detailed information about HP One-Button Disaster Recovery.

## How to contact HP

You can also use the HP Customer Call Centers for specialist technical help. Contact details can be found at [www.hp.com](http://www.hp.com). Click on the link to "contact HP".

To make the best use of this service, we ask that you work with our Support Specialists to resolve any issues with your drive. This may include downloading diagnostic software, that will assist in the rapid resolution of your problems. If you do not have web access, a full listing of HP Customer Call Centers, correct at time of printing, is given in the online User's Guide on the *HP StorageWorks Tape* CD-ROM.

# Replacing your tape drive

If your tape drive proves to be faulty and cannot be repaired and it is still covered by the original warranty, it will be replaced.

## To disconnect your drive

- 1** Unpack your replacement drive, and retain the packaging.
  - 2** Switch off your server to power off the tape drive and any other devices that are on the same SCSI bus.
  - 3** Remove the cover from the server, see page 23.
  - 4** Observing normal anti-static precautions (see page 23) remove any screws that are holding the tape drive in place.
  - 5** Disconnect the drive from the server's power and SCSI cables and slide it carefully out of the mounting bay.
  - 6** Put the drive into the packaging that contained the replacement drive.
  - 7** Return the faulty drive to your local HP Service Center. Instructions on where to return faulty drives will be shipped with the replacement drive.
- Note** If you are not replacing the drive immediately, you should insert a blanking plate into the empty bay. Replace the cover on the server and secure with screws, as appropriate.

## To reconnect your tape drive

Follow the step-by-step instructions in this Getting Started guide.







<http://www.hp.com/support/ultrium>



**Q1538-90905**