

Introduction to WAN Technologies

This chapter introduces the various protocols and technologies used in wide-area network (WAN) environments. Topics summarized here include point-to-point links, circuit switching, packet switching, virtual circuits, dialup services, and WAN devices. Chapters in Part 3, “WAN Technologies,” of this book address specific technologies in more detail.

What is a WAN?

A WAN is a data communications network that covers a relatively broad geographic area and often uses transmission facilities provided by common carriers, such as telephone companies. WAN technologies function at the lower three layers of the OSI reference model: the physical layer, the data link layer, and the network layer. Figure 3-1 illustrates the relationship between the common WAN technologies and the OSI model.

Figure 3-1 WAN technologies operate at the lowest levels of the OSI model.

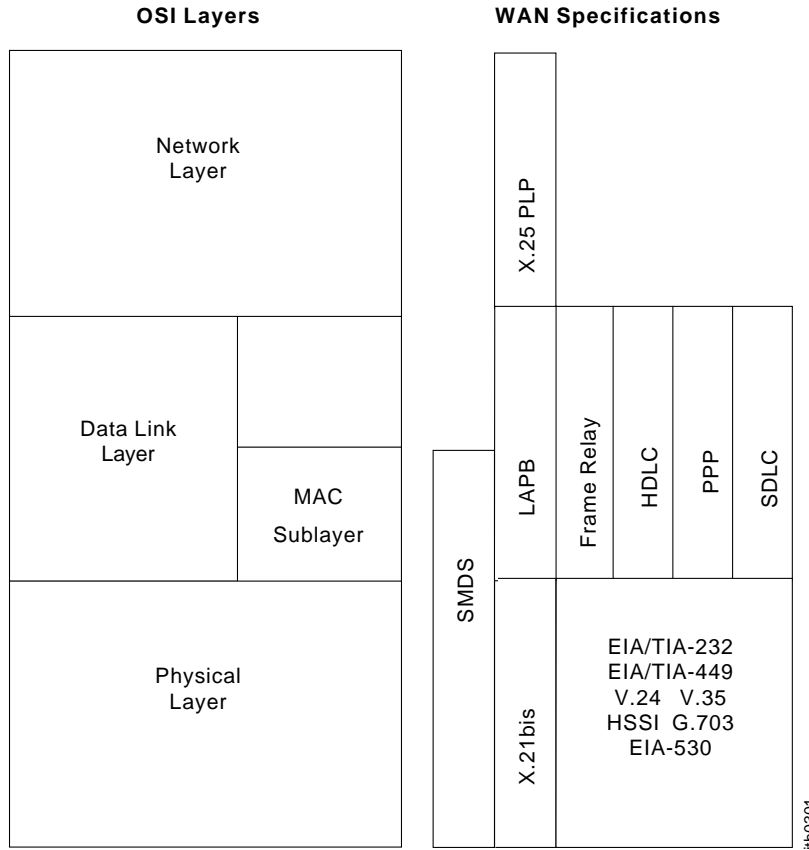

Point-to-Point Links

A *point-to-point link* provides a single, preestablished WAN communications path from the customer premises through a carrier network, such as a telephone company, to a remote network. A point-to-point link is also known as a leased line because its established path is permanent and fixed for each remote network reached through the carrier facilities. The carrier company reserves point-to-point links for the private use of the customer. These links accommodate two types of transmissions: datagram transmissions, which are composed of individually addressed frames, and data-stream transmissions, which are composed of a stream of data for which address checking occurs only once. Figure 3-2 illustrates a typical point-to-point link through a WAN.

Figure 3-2 A typical point-to-point link operates through a WAN to a remote network.

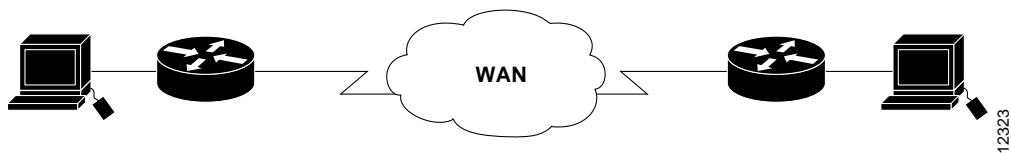

Circuit Switching

Circuit switching is a WAN switching method in which a dedicated physical circuit is established, maintained, and terminated through a carrier network for each communication session. Circuit switching accommodates two types of transmissions: datagram transmissions and data-stream transmissions. Used extensively in telephone company networks, circuit switching operates much like a normal telephone call. Integrated Services Digital Network (ISDN) is an example of a circuit-switched WAN technology, and is illustrated in Figure 3-3.

Figure 3-3 A circuit- switched WAN undergoes a process similar to that used for a telephone call.

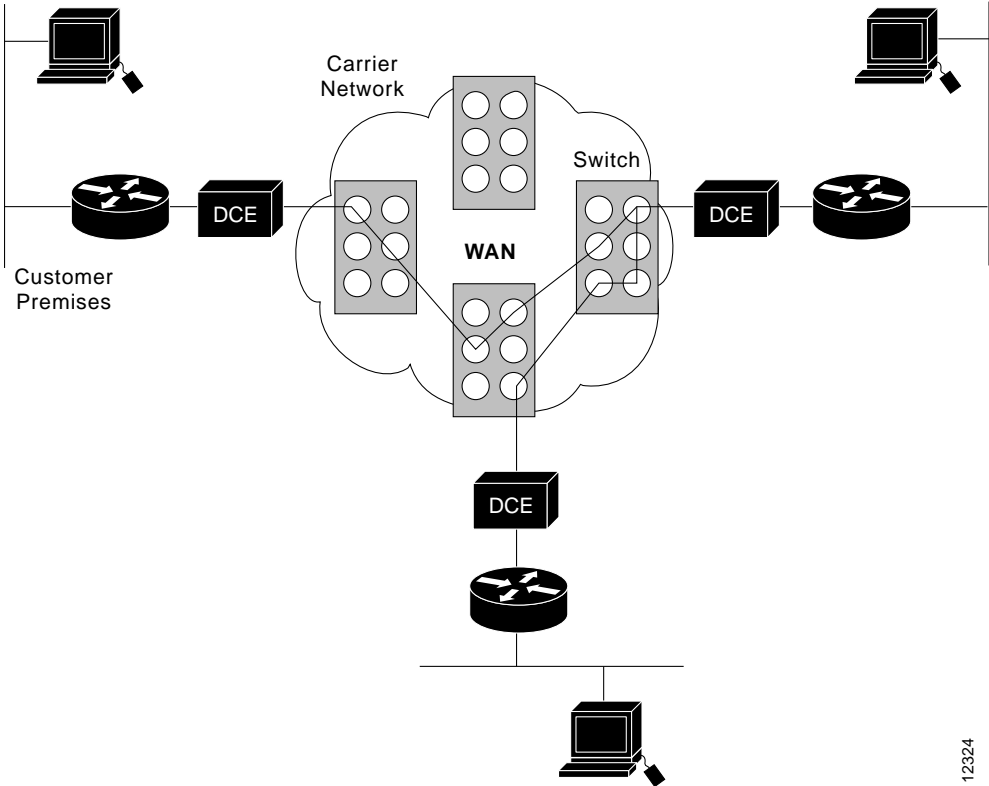

Packet Switching

Packet switching is a WAN switching method in which network devices share a single point-to-point link to transport packets from a source to a destination across a carrier network. Statistical multiplexing is used to enable devices to share these circuits. Asynchronous Transfer Mode (ATM), Frame Relay, Switched Multimegabit Data Service (SMDS), and X.25 are examples of packet-switched WAN technologies (see Figure 3-4).

Figure 3-4 Packet switching transfers packets across a carrier network.

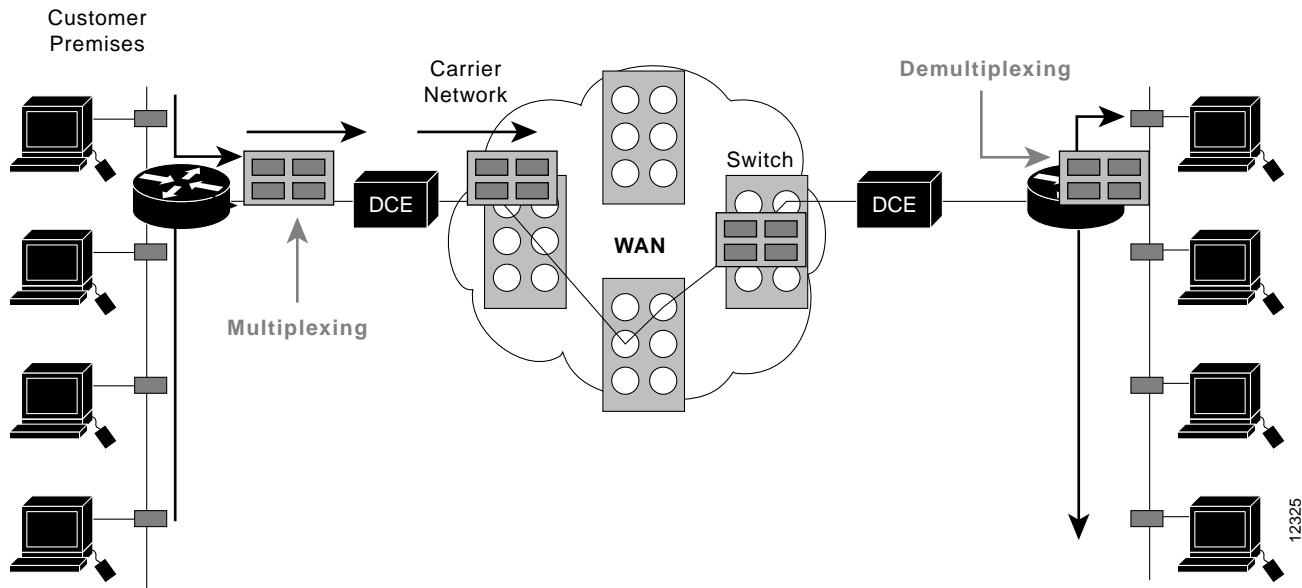

WAN Virtual Circuits

A virtual circuit is a logical circuit created to ensure reliable communication between two network devices. Two types of virtual circuits exist: *switched virtual circuits (SVCs)* and *permanent virtual circuits (PVCs)*.

SVCs are virtual circuits that are dynamically established on demand and terminated when transmission is complete. Communication over an *SVC* consists of three phases: circuit establishment, data transfer, and circuit termination. The establishment phase involves creating the virtual circuit between the source and destination devices. Data transfer involves transmitting data between the devices over the virtual circuit, and the circuit-termination phase involves tearing down the virtual circuit between the source and destination devices. *SVCs* are used in situations in which data transmission between devices is sporadic, largely because *SVCs* increase bandwidth used due to the circuit establishment and termination phases, but decrease the cost associated with constant virtual circuit availability.

A *PVC* is a permanently established virtual circuit that consists of one mode: data transfer. *PVCs* are used in situations in which data transfer between devices is constant. *PVCs* decrease the bandwidth use associated with the establishment and termination of virtual circuits, but increase costs due to constant virtual circuit availability.

WAN Dialup Services

Dialup services offer cost-effective methods for connectivity across WANs. Two popular dialup implementations are dial-on-demand routing (DDR) and dial backup.

DDR is a technique whereby a router can dynamically initiate and close a circuit-switched session as transmitting end station demand. A router is configured to consider certain traffic interesting (such as traffic from a particular protocol) and other traffic uninteresting. When the router receives interesting traffic destined for a remote network, a circuit is established and the traffic is transmitted normally. If the router receives uninteresting traffic and a circuit is already established, that traffic also is transmitted normally. The router maintains an idle timer that is reset only when interesting

traffic is received. If the router receives no interesting traffic before the idle timer expires, however, the circuit is terminated. Likewise, if uninteresting traffic is received and no circuit exists, the router drops the traffic. Upon receiving interesting traffic, the router initiates a new circuit. DDR can be used to replace point-to-point links and switched multiaccess WAN services.

Dial backup is a service that activates a backup serial line under certain conditions. The secondary serial line can act as a backup link that is used when the primary link fails or as a source of additional bandwidth when the load on the primary link reaches a certain threshold. Dial backup provides protection against WAN performance degradation and downtime.

WAN Devices

WANs use numerous types of devices that are specific to WAN environments. WAN switches, access servers, modems, CSU/DSUs, and ISDN terminal adapters are discussed in the following sections. Other devices found in WAN environments that are exclusive to WAN implementations include routers, ATM switches, and multiplexers.

WAN Switch

A WAN switch is a multiport internetworking device used in carrier networks. These devices typically switch such traffic as Frame Relay, X.25, and SMDS and operate at the data link layer of the OSI reference model. Figure 3-5 illustrates two routers at remote ends of a WAN that are connected by WAN switches.

Figure 3-5 Two routers at remote ends of a WAN can be connected by WAN switches.

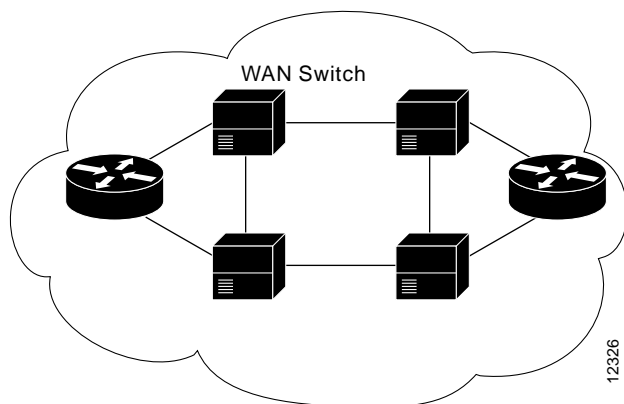

Access Server

An access server acts as a concentration point for dial-in and dial-out connections. Figure 3-6 illustrates an access server concentrating dial-out connections into a WAN.

Figure 3-6 An access server concentrates dial-out connections into a WAN.

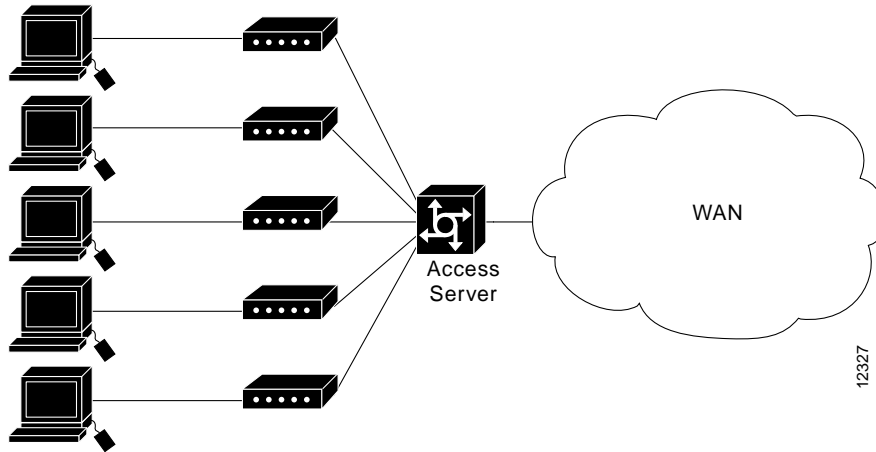

Modem

A modem is a device that interprets digital and analog signals, enabling data to be transmitted over voice-grade telephone lines. At the source, digital signals are converted to a form suitable for transmission over analog communication facilities. At the destination, these analog signals are returned to their digital form. Figure 3-7 illustrates a simple modem-to-modem connection through a WAN.

Figure 3-7 A modem connection through a WAN handles analog and digital signals.

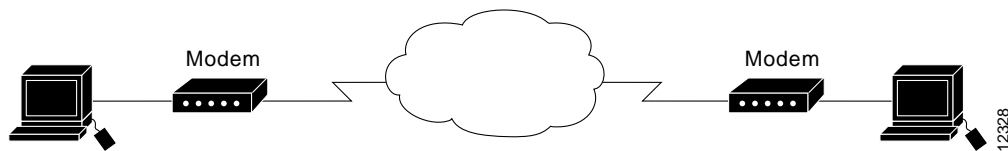

CSU/DSU

A channel service unit/digital service unit (CSU/DSU) is a digital-interface device (or sometimes two separate digital devices) that adapts the physical interface on a data terminal equipment (DTE) device (such as a terminal) to the interface of a data circuit-terminating (DCE) device (such as a switch) in a switched-carrier network. The CSU/DSU also provides signal timing for communication between these devices. Figure 3-8 illustrates the placement of the CSU/DSU in a WAN implementation.

Figure 3-8 The CSU/DSU stands between the switch and the terminal.

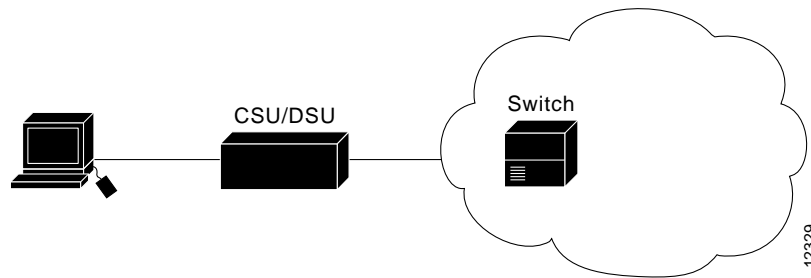

ISDN Terminal Adapter

An ISDN terminal adapter is a device used to connect ISDN Basic Rate Interface (BRI) connections to other interfaces, such as EIA/TIA-232. A terminal adapter is essentially an ISDN modem. Figure 3-9 illustrates the placement of the terminal adapter in an ISDN environment.

Figure 3-9 The terminal adapter connects the ISDN terminal adapter to other interfaces.

