



Sun™ Expert3D Graphics Card Installation Guide

Sun Microsystems, Inc.
901 San Antonio Road
Palo Alto, CA 94303-4900 U.S.A.
650-960-1300

Part No. 806-1859-11
September 2000, [Revision B](#)

[Send comments about this document to: docfeedback@sun.com](mailto:docfeedback@sun.com)

Copyright 2000 Sun Microsystems, Inc., 901 San Antonio Road • Palo Alto, CA 94303 USA. All rights reserved.

This product or document is protected by copyright and distributed under licenses restricting its use, copying, distribution, and decompilation. No part of this product or document may be reproduced in any form by any means without prior written authorization of Sun and its licensors, if any. Third-party software, including font technology, is copyrighted and licensed from Sun suppliers.

Parts of the product may be derived from Berkeley BSD systems, licensed from the University of California. UNIX is a registered trademark in the U.S. and other countries, exclusively licensed through X/Open Company, Ltd. OpenGL is a registered trademark of Silicon Graphics, Inc.

Sun, Sun Microsystems, the Sun logo, Sun Enterprise, docs.sun.com, AnswerBook2, SunService, OpenWindows, SunVTS, Ultra, and Solaris are trademarks or registered trademarks of Sun Microsystems, Inc. in the United States and in other countries. All SPARC trademarks are used under license and are trademarks or registered trademarks of SPARC International, Inc. in the United States and in other countries. Products bearing SPARC trademarks are based upon an architecture developed by Sun Microsystems, Inc.

The OPEN LOOK and Sun™ Graphical User Interface was developed by Sun Microsystems, Inc. for its users and licensees. Sun acknowledges the pioneering efforts of Xerox in researching and developing the concept of visual or graphical user interfaces for the computer industry. Sun holds a non-exclusive license from Xerox to the Xerox Graphical User Interface, which license also covers Sun's licensees who implement OPEN LOOK GUIs and otherwise comply with Sun's written license agreements.

Federal Acquisitions: Commercial Software—Government Users Subject to Standard License Terms and Conditions.

DOCUMENTATION IS PROVIDED "AS IS" AND ALL EXPRESS OR IMPLIED CONDITIONS, REPRESENTATIONS AND WARRANTIES, INCLUDING ANY IMPLIED WARRANTY OF MERCHANTABILITY, FITNESS FOR A PARTICULAR PURPOSE OR NON-INFRINGEMENT, ARE DISCLAIMED, EXCEPT TO THE EXTENT THAT SUCH DISCLAIMERS ARE HELD TO BE LEGALLY INVALID.

Copyright 2000 Sun Microsystems, Inc., 901 San Antonio Road • Palo Alto, CA 94303 Etats-Unis. Tous droits réservés.

Ce produit ou document est protégé par un copyright et distribué avec des licences qui en restreignent l'utilisation, la copie, la distribution, et la décompilation. Aucune partie de ce produit ou document ne peut être reproduite sous aucune forme, par quelque moyen que ce soit, sans l'autorisation préalable et écrite de Sun et de ses bailleurs de licence, s'il y en a. Le logiciel détenu par des tiers, et qui comprend la technologie relative aux polices de caractères, est protégé par un copyright et licencié par des fournisseurs de Sun.

Des parties de ce produit pourront être dérivées des systèmes Berkeley BSD licenciés par l'Université de Californie. UNIX est une marque déposée aux Etats-Unis et dans d'autres pays et licenciée exclusivement par X/Open Company, Ltd. OpenGL est une marque déposée de Silicon Graphics, Inc.

Sun, Sun Microsystems, le logo Sun, Sun Enterprise, docs.sun.com, AnswerBook2, SunService, OpenWindows, SunVTS, Ultra, et Solaris sont des marques de fabrique ou des marques déposées, ou marques de service, de Sun Microsystems, Inc. aux Etats-Unis et dans d'autres pays. Toutes les marques SPARC sont utilisées sous licence et sont des marques de fabrique ou des marques déposées de SPARC International, Inc. aux Etats-Unis et dans d'autres pays. Les produits portant les marques SPARC sont basés sur une architecture développée par Sun Microsystems, Inc.

L'interface d'utilisation graphique OPEN LOOK et Sun™ a été développée par Sun Microsystems, Inc. pour ses utilisateurs et licenciés. Sun reconnaît les efforts de pionniers de Xerox pour la recherche et le développement du concept des interfaces d'utilisation visuelle ou graphique pour l'industrie de l'informatique. Sun détient une licence non exclusive de Xerox sur l'interface d'utilisation graphique Xerox, cette licence couvrant également les licenciés de Sun qui mettent en place l'interface d'utilisation graphique OPEN LOOK et qui en outre se conforment aux licences écrites de Sun.

CETTE PUBLICATION EST FOURNIE "EN L'ETAT" ET AUCUNE GARANTIE, EXPRESSE OU IMPLICITE, N'EST ACCORDEE, Y COMPRIS DES GARANTIES CONCERNANT LA VALEUR MARCHANDE, L'APTITUDE DE LA PUBLICATION A REPOUDRE A UNE UTILISATION PARTICULIERE, OU LE FAIT QU'ELLE NE SOIT PAS CONTREFAISANTE DE PRODUIT DE TIERS. CE DENI DE GARANTIE NE S'APPLIQUERAIT PAS, DANS LA MESURE OU IL SERAIT TENU JURIDIQUEMENT NUL ET NON AVENU.



Regulatory Compliance Statements

Your Sun product is marked to indicate its compliance class:

- Federal Communications Commission (FCC) — USA
- Industry Canada Equipment Standard for Digital Equipment (ICES-003) - Canada
- Voluntary Control Council for Interference (VCCI) — Japan
- Bureau of Standards Metrology and Inspection (BSMI) — Taiwan

Please read the appropriate section that corresponds to the marking on your Sun product before attempting to install the product.

FCC Class A Notice

This device complies with Part 15 of the FCC Rules. Operation is subject to the following two conditions:

1. This device may not cause harmful interference.
2. This device must accept any interference received, including interference that may cause undesired operation.

Note: This equipment has been tested and found to comply with the limits for a Class A digital device, pursuant to Part 15 of the FCC Rules. These limits are designed to provide reasonable protection against harmful interference when the equipment is operated in a commercial environment. This equipment generates, uses, and can radiate radio frequency energy, and if it is not installed and used in accordance with the instruction manual, it may cause harmful interference to radio communications. Operation of this equipment in a residential area is likely to cause harmful interference, in which case the user will be required to correct the interference at his own expense.

Shielded Cables: Connections between the workstation and peripherals must be made using shielded cables to comply with FCC radio frequency emission limits. Networking connections can be made using unshielded twisted-pair (UTP) cables.

Modifications: Any modifications made to this device that are not approved by Sun Microsystems, Inc. may void the authority granted to the user by the FCC to operate this equipment.

FCC Class B Notice

This device complies with Part 15 of the FCC Rules. Operation is subject to the following two conditions:

1. This device may not cause harmful interference.
2. This device must accept any interference received, including interference that may cause undesired operation.

Note: This equipment has been tested and found to comply with the limits for a Class B digital device, pursuant to Part 15 of the FCC Rules. These limits are designed to provide reasonable protection against harmful interference in a residential installation. This equipment generates, uses and can radiate radio frequency energy and, if not installed and used in accordance with the instructions, may cause harmful interference to radio communications. However, there is no guarantee that interference will not occur in a particular installation. If this equipment does cause harmful interference to radio or television reception, which can be determined by turning the equipment off and on, the user is encouraged to try to correct the interference by one or more of the following measures:

- Reorient or relocate the receiving antenna.
- Increase the separation between the equipment and receiver.
- Connect the equipment into an outlet on a circuit different from that to which the receiver is connected.
- Consult the dealer or an experienced radio/television technician for help.

Shielded Cables: Connections between the workstation and peripherals must be made using shielded cables in order to maintain compliance with FCC radio frequency emission limits. Networking connections can be made using unshielded twisted pair (UTP) cables.

Modifications: Any modifications made to this device that are not approved by Sun Microsystems, Inc. may void the authority granted to the user by the FCC to operate this equipment.

ICES-003 Class A Notice - Avis NMB-003, Classe A

This Class A digital apparatus complies with Canadian ICES-003.

Cet appareil numérique de la classe A est conforme à la norme NMB-003 du Canada.

ICES-003 Class B Notice - Avis NMB-003, Classe B

This Class B digital apparatus complies with Canadian ICES-003.

Cet appareil numérique de la classe B est conforme à la norme NMB-003 du Canada.

VCCI 基準について

クラス A VCCI 基準について

クラス A VCCI の表示があるワークステーションおよびオプション製品は、クラス A 情報技術装置です。これらの製品には、下記の項目が該当します。

この装置は、情報処理装置等電波障害自主規制協議会 (VCCI) の基準に基づくクラス A 情報技術装置です。この装置を家庭環境で使用すると電波妨害を引き起こすことがあります。この場合には使用者が適切な対策を講ずるよう要求されることがあります。

クラス B VCCI 基準について

クラス B VCCI の表示  があるワークステーションおよびオプション製品は、クラス B 情報技術装置です。これらの製品には、下記の項目が該当します。

この装置は、情報処理装置等電波障害自主規制協議会 (VCCI) の基準に基づくクラス B 情報技術装置です。この装置は、家庭環境で使用することを目的としていますが、この装置がラジオやテレビジョン受信機に近接して使用されると、受信障害を引き起こすことがあります。取扱説明書に従って正しい取り扱いをしてください。

BSMI Class A Notice

The following statement is applicable to products shipped to Taiwan and marked as Class A on the product compliance label.

警告使用者：
這是甲類的資訊產品，在居住的環境中使用時，可能會造成射頻干擾，在這種情況下，使用者會被要求採取某些適當的對策。

Contents

Preface xiii

- 1. Sun Expert3D Graphics Card Overview** 1
 - Installation Kit 2

- 2. Installing the Sun Expert3D Graphics Card** 3
 - Before Installation 3
 - Installing the Hardware 3
 - Installing the Sun Expert3D Card in an Ultra 60 System 4
 - Installing the Sun Expert3D Card in an Ultra 80 System 6
 - Installing the Sun Expert3D Card in an Sun Blade 1000 System 8
 - Installing the Sun Expert3D Card in a Sun Enterprise 450 Server 10
 - Installing the Sun Expert3D Card in a Sun Enterprise 420R System 13

- 3. Installing the Sun Expert3D Software** 15
 - Software Requirements 15
 - Sun Expert3D Software Package 16
 - Software Package Locations 16
 - Sun Expert3D Software Package Names 16
 - Sun Expert3D Patches 17
 - Sun OpenGL for Solaris Software 17

Software Package Locations	17
Sun OpenGL for Solaris Software Package Names	18
Sun OpenGL for Solaris Patches	19
Installing Sun Expert3D Software	20
Removing Sun Expert3D Software	24
Multiple Frame Buffer Configuration	25
Sun Expert3D as Default Console	25
Sun Expert3D Man Pages	27
Changing the Monitor Screen Resolution	27
A. Sun Expert3D Graphics Card Features and Specifications	29
Sun Expert3D Graphics Card Features	29
Sun Expert3D Specifications	32
Sun Expert3D Multiview Ports	35
Sun Expert3D Screen Resolutions and Video Formats	38

Figures

FIGURE 1-1	Sun Expert3D Graphics Accelerator	1
FIGURE 1-2	Sun Expert3D External I/O Port Connectors	2
FIGURE 2-1	Ultra 60 PCI 66-Mhz and 33-Mhz Connector Locations	4
FIGURE 2-2	Installing Sun Expert3D Graphics Card in an Ultra 60 System	5
FIGURE 2-3	Ultra 80 PCI 66-Mhz and 33-Mhz Connector Locations	6
FIGURE 2-4	Installing Sun Expert3D Graphics Card in an Ultra 80 System	7
FIGURE 2-5	Installing Sun Expert3D Graphics Card in a Sun Blade 1000 System	9
FIGURE 2-6	Installing Sun Expert3D Graphics Card in an Enterprise 450 System	11
FIGURE 2-7	Securing the Sun Expert3D Card Faceplate	11
FIGURE 2-8	Installing Sun Expert3D Graphics Card in a Sun Enterprise 450 Server	12
FIGURE 2-9	Removing a Sun Enterprise 420R Filler Panel	13
FIGURE 2-10	Installing Sun Expert3D Graphics Card in a Sun Enterprise 420R	14
FIGURE A-1	Sun Expert3D Connectors	32
FIGURE A-2	Sun Expert3D 7-Pin DIN Female Stereo Connector	34
FIGURE A-3	Sun Expert3D Multiview-In and Multiview-Out Connectors	37

Tables

TABLE 2-1	Sun Expert3D and Fan Card PCI Slot Configuration for Sun Enterprise 450	10
TABLE 3-1	Location of Sun Expert3D Software Packages	16
TABLE 3-2	Solaris 2.6, Solaris 7, and Solaris 8 Software Package Names	16
TABLE 3-3	Sun Expert3D Patches	17
TABLE 3-4	Location of Sun OpenGL for Solaris Software Packages	18
TABLE 3-5	Sun OpenGL Version 1.2 and 1.1.2 for Solaris Package Names for Solaris 2.6, Solaris 7, and Solaris 8 Software	18
TABLE 3-6	Sun OpenGL Version 1.2.1 for Solaris Patches	19
TABLE 3-7	Sun OpenGL Version 1.2 for Solaris Patches	19
TABLE 3-8	Sun OpenGL Version 1.1.2 for Solaris Patches	20
TABLE A-1	Sun Expert3D Video Output Port	33
TABLE A-2	Sun Expert3D Stereo Output Port	34
TABLE A-3	Sun Expert3D Multiview-In Port and Multiview-Out Port Pinout	35
TABLE A-4	Sun Expert3D Monitor Resolutions	38

Preface

This guide describes how to install the Sun™ Expert3D graphics accelerator hardware and software in a Sun system.

How This Book Is Organized

Chapter 1 provides an overview of the Sun Expert3D product and lists the supported Sun systems.

Chapter 2 describes how to install the Sun Expert3D graphics card.

Chapter 3 describes how to install Sun Expert3D software.

Appendix A provides Sun Expert3D features, specifications, and multiview configuration.

Using UNIX Commands

This document does not contain information on basic UNIX commands and procedures such as shutting down the system, booting the system, and configuring devices.

See one or more of the following for this information:

- *Solaris 2.x Handbook for SMCC Peripherals*
- AnswerBook2™ online documentation for the Solaris™ 2.x operating environment
- Other software documentation that you received with your system

Typographic Conventions

Typeface	Meaning	Examples
AaBbCc123	The names of commands, files, and directories; on-screen computer output.	Edit your <code>.login</code> file. Use <code>ls -a</code> to list all files. % You have mail.
AaBbCc123	What you type, when contrasted with on-screen computer output.	% su Password:
<i>AaBbCc123</i>	Book titles, new words, or terms; words to be emphasized; command-line variable: replace with a real name or value.	Read Chapter 6 in the <i>User's Guide</i> . These are called <i>class</i> options. You <i>must</i> be root to do this. To delete a file, type <code>rm filename</code> .

Shell Prompts

Shell	Prompt
C shell	%
C shell superuser	#
Bourne shell and Korn shell	\$
Bourne shell and Korn shell superuser	#

Accessing Sun Documentation Online

The `docs.sun.comsm` web site enables you to access a select group of Sun technical documentation on the Web. You can browse the `docs.sun.com` archive or search for a specific book title or subject at:

<http://docs.sun.com>

Ordering Sun Documentation

Fatbrain.com, an Internet professional bookstore, stocks select product documentation from Sun Microsystems, Inc.

For a list of documents and how to order them, visit the Sun Documentation Center on Fatbrain.com at:

<http://www.fatbrain.com/documentation/sun>

Sun Welcomes Your Comments

Sun is interested in improving its documentation and welcomes your comments and suggestions. You can email your comments to Sun at:

`docfeedback@sun.com`

Please include the part number (806-1859-11) of your document in the subject line of your email.

Sun Expert3D Graphics Card Overview

The Sun Expert3D graphics accelerator (FIGURE 1-1) is a high-resolution, high-performance graphics frame buffer that provides hardware texture mapping. The Sun Expert3D graphics card supports screen resolutions that include 1920 x 1200 double-buffered, z-buffered, and 1280 x 1024 stereo displays.

This document provides Sun Expert3D graphics card installation instructions for the following Sun workstations:

- Sun Ultra™ 60 system
- Sun Ultra 80 system
- Sun Blade™ 1000 system
- Sun Enterprise™ 450 server
- Sun Enterprise 420R system

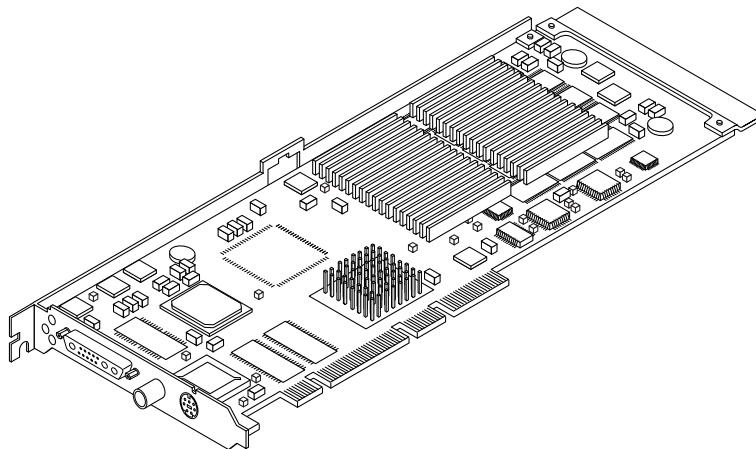

FIGURE 1-1 Sun Expert3D Graphics Accelerator

For assistance and other information not found in this document concerning the Sun Expert3D card, see SunServiceSM at <http://www.sun.com/service/online/>.

FIGURE 1-2 shows the Sun Expert3D graphics card external I/O ports, which are described in Appendix A, “Sun Expert3D Graphics Card Features and Specifications.”

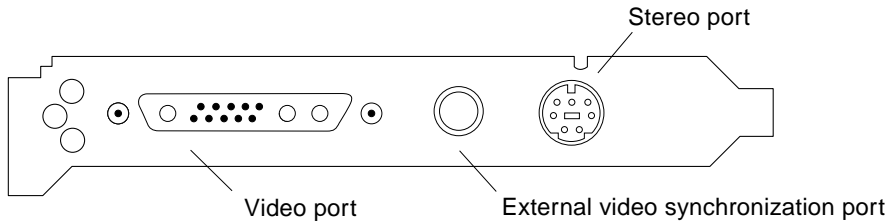

FIGURE 1-2 Sun Expert3D External I/O Port Connectors

Installation Kit

The Expert3D graphics card installation kit includes:

- Sun Expert3D graphics card
- Antistatic wrist strap
- Sun Expert3D software (CD-ROM)
- Sun Expert3D multiview cable
- *Sun Expert3D Graphics Card Installation Guide*, this document

Updated versions of SunTM OpenGL[®] for SolarisTM and the latest graphics system software patches for the Sun Expert3D graphics card are available at:

<http://www.sun.com/software/graphics/OpenGL/>

Installing the Sun Expert3D Graphics Card

This chapter provides Sun Expert3D hardware installation information.

- “Installing the Sun Expert3D Card in an Ultra 60 System” on page 4
- “Installing the Sun Expert3D Card in an Ultra 80 System” on page 6
- “Installing the Sun Expert3D Card in an Sun Blade 1000 System” on page 8
- “Installing the Sun Expert3D Card in a Sun Enterprise 450 Server” on page 10
- “Installing the Sun Expert3D Card in a Sun Enterprise 420R System” on page 13

Before Installation

Refer to the *Solaris Handbook for Sun Peripherals* that corresponds to your operating environment. The handbook describes how to shut down the system safely before installing any internal cards, and rebooting your system after installation.

Installing the Hardware

Refer to the hardware installation documentation provided with your Sun workstation for general instructions on accessing your system internal modules, and handling Sun PCI graphics cards.

Installing the Sun Expert3D Card in an Ultra 60 System

The Sun Expert3D graphics card connects into the 66-Mhz or 33-Mhz PCI connector on the Sun Ultra 60 motherboard. Best performance is achieved by putting the Sun Expert3D card into the Ultra 60 66-Mhz PCI slot. The Sun Ultra 60 supports up to two Sun Expert3D cards.

1. Shut down your workstation and remove the Ultra 60 enclosure.
2. Attach the antistatic wrist strap to your wrist and to the power supply.
3. Locate the Ultra 60 PCI 66-Mhz and 33-Mhz connectors (FIGURE 2-1).

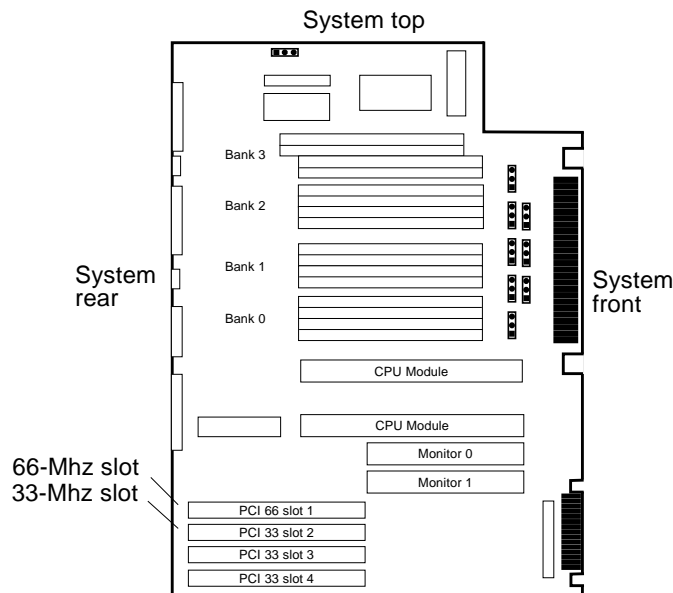

FIGURE 2-1 Ultra 60 PCI 66-Mhz and 33-Mhz Connector Locations

4. Using a No. 2 Phillips screwdriver, remove the screw that secures the PCI slot filler panel and remove the filler panel.
5. Install the Sun Expert3D graphics card.
 - a. Position the Sun Expert3D card into the chassis (FIGURE 2-2).

- b. Guide the Sun Expert3D backplate bracket tab into the chassis back-panel opening; guide the opposite end of the card into the fan bracket card guide so that the card is aligned evenly with the motherboard slot.
- c. Holding the two upper corners of the Sun Expert3D card, push the card straight down into the slot until it is fully seated.
- d. Using a No. 2 Phillips screwdriver, replace the screw securing the Sun Expert3D bracket tab to the system chassis.

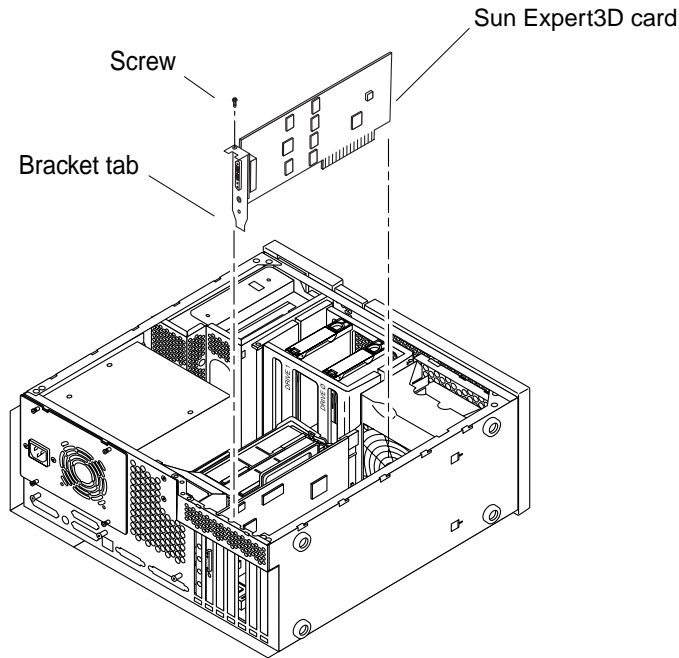

FIGURE 2-2 Installing Sun Expert3D Graphics Card in an Ultra 60 System

6. Replace the Ultra 60 enclosure and go to Chapter 3.

Note – See “Sun Expert3D Multiview Ports” on page 35 for procedures on cabling two or more Sun Expert3D graphics cards for multiviewing.

Installing the Sun Expert3D Card in an Ultra 80 System

The Sun Expert3D graphics card connects into the 66-Mhz or 33-Mhz PCI connector on the Sun Ultra 80 motherboard. Best performance is achieved by putting the Sun Expert3D card into the Ultra 80 66-Mhz PCI slot. The Sun Ultra 80 supports up to two Sun Expert3D cards.

1. Shut down your workstation and remove the Ultra 80 enclosure.
2. Attach the antistatic wrist strap to your wrist and power supply.
3. Locate the Ultra 80 PCI 66-Mhz and 33-Mhz connectors (FIGURE 2-3).

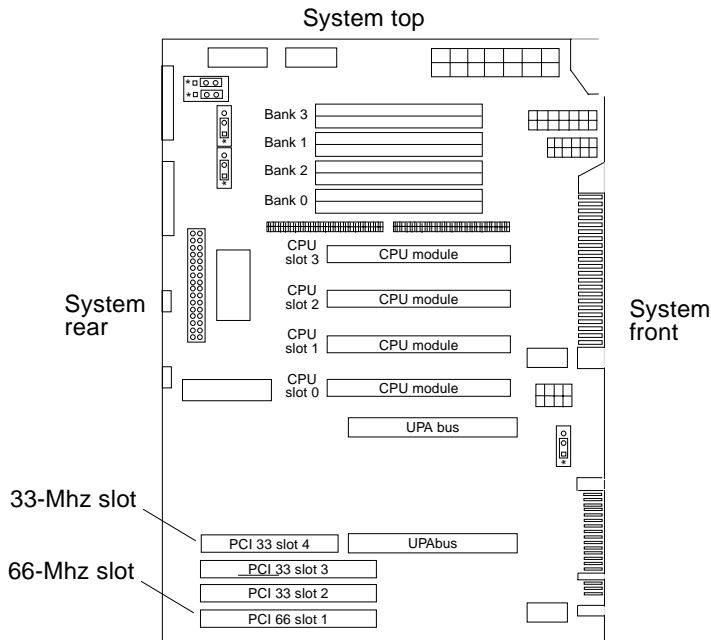

FIGURE 2-3 Ultra 80 PCI 66-Mhz and 33-Mhz Connector Locations

4. Using a No. 2 Phillips screwdriver, remove the screw that secures the PCI slot filler panel and remove the filler panel.
5. Install the Sun Expert3D graphics card.
 - a. Position the Sun Expert3D card into the chassis.

- b. Lower the Sun Expert3D connector so that it touches its associated PCI card slot on the motherboard (FIGURE 2-4).
- c. Guide the Sun Expert3D backplate bracket tab into the chassis back panel.
- d. At the two upper corners of the card, push the card straight down into the slot until the card is fully seated.
- e. Using a No. 2 Phillips-head screwdriver, replace the screw securing the Sun Expert3D bracket tab to the system unit chassis.

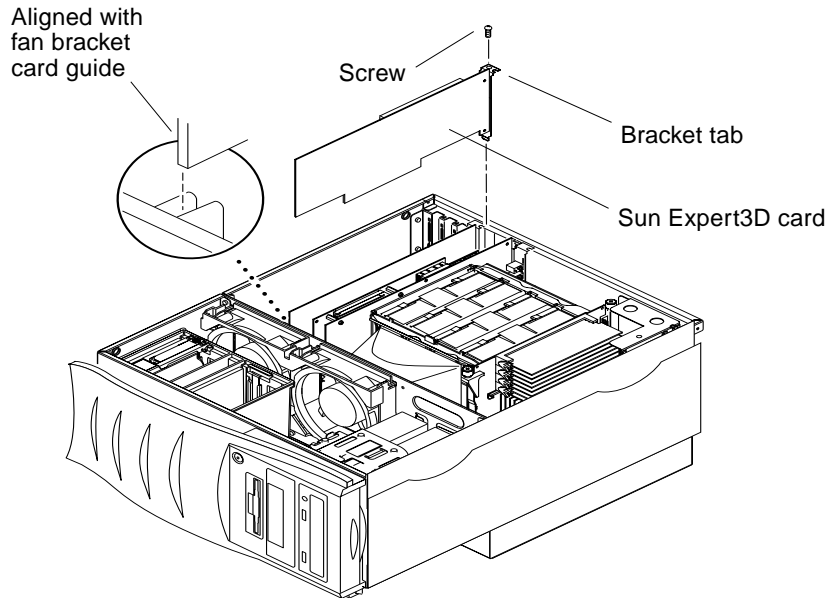

FIGURE 2-4 Installing Sun Expert3D Graphics Card in an Ultra 80 System

6. Replace the side access cover and go to Chapter 3.

Note – See “Sun Expert3D Multiview Ports” on page 35 for procedures on cabling two or more Sun Expert3D graphics cards for multiviewing.

Installing the Sun Expert3D Card in an Sun Blade 1000 System

The Sun Expert3D graphics card connects into a 33-Mhz PCI connector on the Sun Blade 1000 motherboard. The 33-Mhz PCI connectors are the three slots located closest to the CPU module. The Sun Blade 1000 supports up to two Sun Expert3D cards.

- 1. Shut down your system and attach the antistatic wrist strap.**
- 2. Remove the Sun Blade 1000 access panel, and lay the system on its side.**
- 3. Lay the system on its side.**
- 4. Position the Sun Expert3D card in the chassis (FIGURE 2-5).**
- 5. Guide the card bracket tab into the chassis back-panel opening. Guide the opposite end of the card into the fan bracket card guide so that the card is aligned evenly with the motherboard connector.**
- 6. At the two upper corners of the Sun Expert3D card, push the card straight down into the connector until the Sun Expert3D card is fully seated.**
- 7. Using a No. 2 Phillips screwdriver, replace the screw securing the Sun Expert3D card bracket tab to the system chassis.**

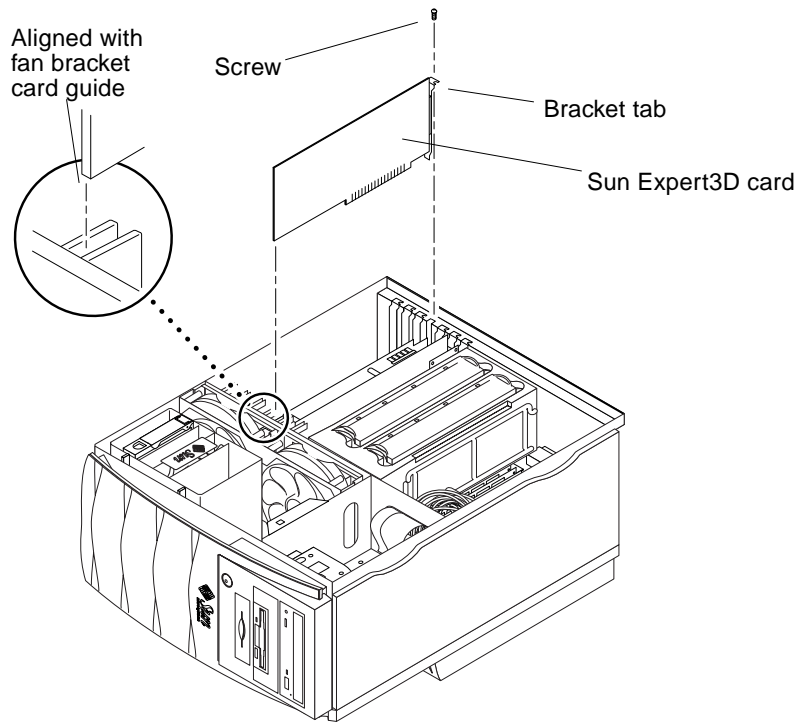

FIGURE 2-5 Installing Sun Expert3D Graphics Card in a Sun Blade 1000 System

8. Replace the side access cover and go to Chapter 3.

Note – See “Sun Expert3D Multiview Ports” on page 35 for procedures on cabling two or more Sun Expert3D graphics cards for multiviewing.

Installing the Sun Expert3D Card in a Sun Enterprise 450 Server

The Sun Enterprise 450 Server supports up to three Sun Expert3D cards.

The Sun Expert3D Installation Kit for your Sun Enterprise 450 is accompanied by a Fan Card Installation Kit. The Fan Card Installation Kit includes:

- Sun Expert3D-F Fan Card
- Sun Expert3D multiview cable (longer for multiple card configurations)

The Sun Expert3D graphics card connects into the 66-Mhz or 33-Mhz PCI connector on the Sun Enterprise 450 motherboard. Each Sun Expert3D card requires a fan card in the adjacent PCI slot below the Sun Expert3D card. See TABLE 2-1 for the Sun Expert3D card and fan card configuration options.

TABLE 2-1 Sun Expert3D and Fan Card PCI Slot Configuration for Sun Enterprise 450

Number of Expert3Ds	Sun Expert3D and Fan Card Configuration
One Expert3D	Sun Expert3D card: use one of the following 66Mhz slots: 4, 5, or 6 Fan card: use adjacent slots: 3, 4, or 5, respectively.
Two Expert3Ds	Sun Expert3D card: use 66Mhz slots 4 and 6. Fan card: use adjacent slots: 3 and 5.
Three Expert3Ds	Sun Expert3D card: use slots 2 (33Mhz), 4 (66Mhz), and 6 (66Mhz). Fan card: use adjacent slots: 1, 3, and 5.

- 1. Shut down your system and remove the Enterprise 450 enclosure.**
- 2. Attach the antistatic wrist strap,**
- 3. If necessary, remove the system rear panel filler panel.**
- 4. Insert the Sun Expert3D card into the appropriate slot on the main logic board (FIGURE 2-6).**
 - a. Insert the left side of the Sun Expert3D card into the selected opening on the rear panel. At the same time, insert the right side of the card into the corresponding groove on the CPU cage.**

b. Push the Sun Expert3D card into the slot on the main logic board.

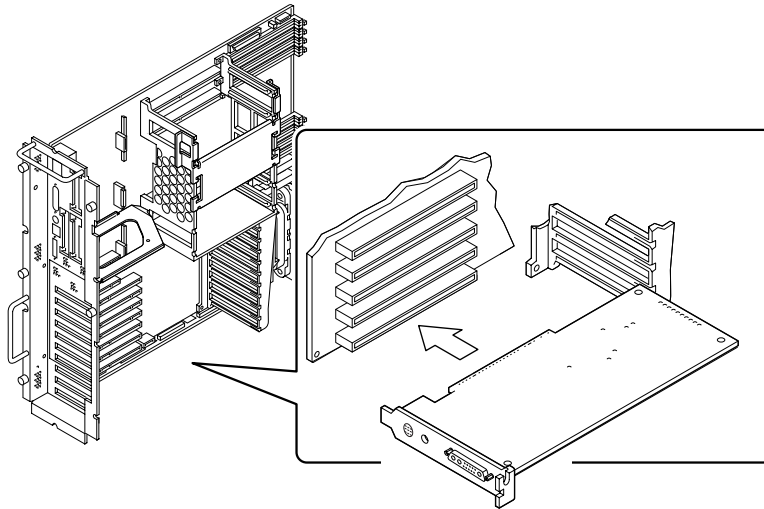

FIGURE 2-6 Installing Sun Expert3D Graphics Card in an Enterprise 450 System

c. Align the left side of the card with the appropriate opening on the rear panel.

d. Push the card into the corresponding slot on the main logic board.

5. Secure the Sun Expert3D card faceplate to the rear panel with the Phillips screw.

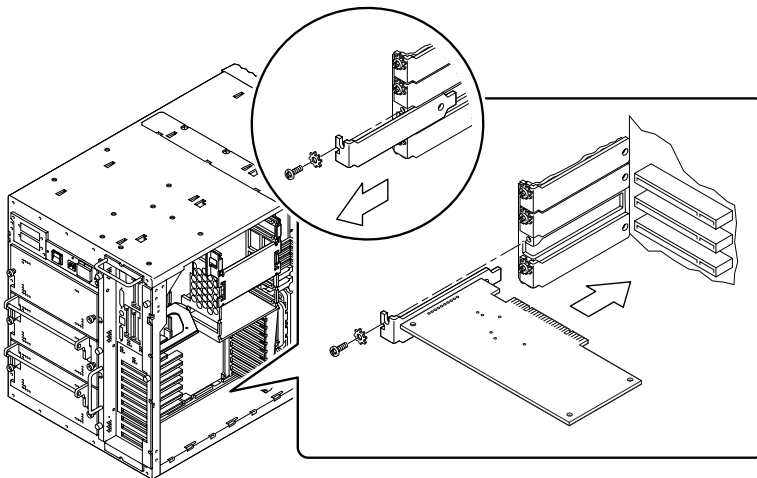

FIGURE 2-7 Securing the Sun Expert3D Card Faceplate

6. Install the Sun Expert3D fan card.

Each Sun Expert3D card requires a fan card in the adjacent PCI slot below the Sun Expert3D card (see TABLE 2-1). Use the procedure in steps 4 through 5 for installing the fan card.

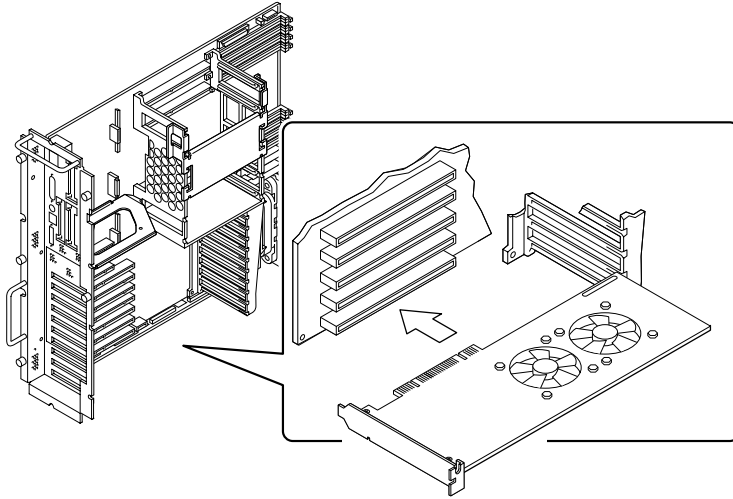

FIGURE 2-8 Installing Sun Expert3D Graphics Card in a Sun Enterprise 450 Server

7. Replace the side access cover and go to Chapter 3.

Note – See “Sun Expert3D Multiview Ports” on page 35 for procedures on cabling two or more Sun Expert3D graphics cards for multiviewing.

Installing the Sun Expert3D Card in a Sun Enterprise 420R System

The Sun Expert3D graphics card connects into the 66Mhz or 33Mhz PCI connector on the Sun Enterprise 420R motherboard. Best performance is achieved by putting the Sun Expert3D card into the Enterprise 420R 66Mhz PCI slot. The Sun Enterprise 420R supports up to two Sun Expert3D cards.

1. Shut down your system and remove the Sun Enterprise 450 enclosure.
2. Attach the antistatic wrist strap,
3. If necessary, remove the system rear panel filler panel.

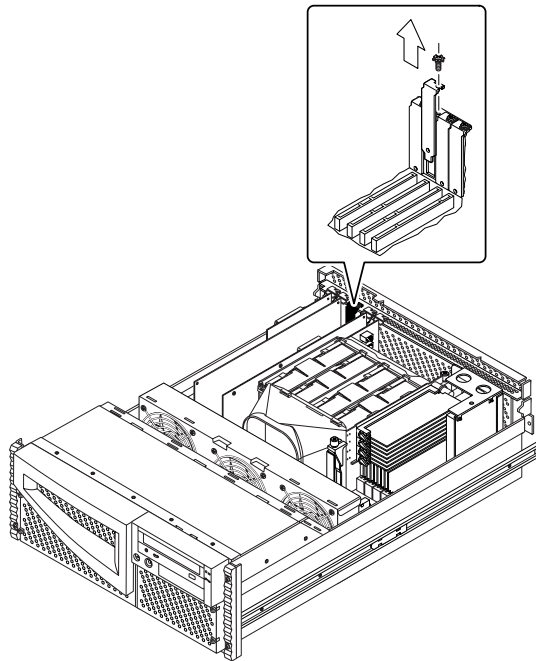

FIGURE 2-9 Removing a Sun Enterprise 420R Filler Panel

4. Insert the Sun Expert3D into the appropriate connector slot on the main logic board.

- a. Insert the faceplate end of the Sun Expert3D card into appropriate opening in the system back panel.
- b. Guide the opposite end of the Sun Expert3D card into the card slot on the fan tray assembly.
- c. Push the card into the connector on the main logic board.
Apply even pressure along the edge of the card.

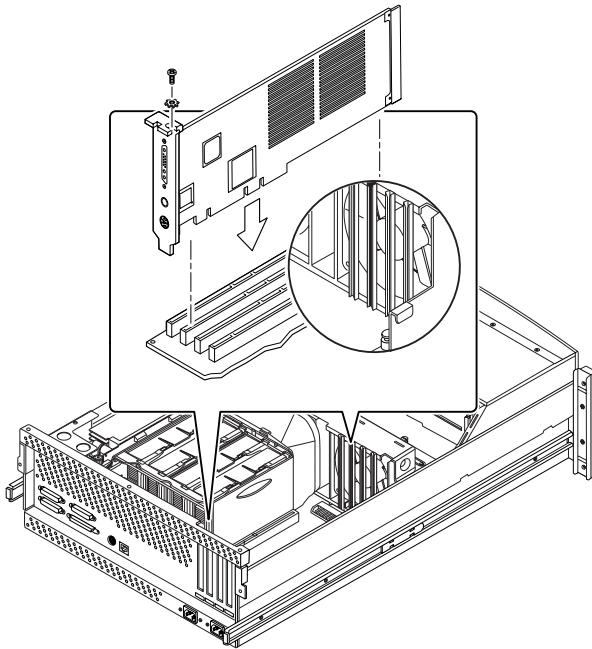

FIGURE 2-10 Installing Sun Expert3D Graphics Card in a Sun Enterprise 420R

5. Replace the side access cover and go to Chapter 3.

Note – See “Sun Expert3D Multiview Ports” on page 35 for procedures on cabling two or more Sun Expert3D graphics cards for multiviewing.

Installing the Sun Expert3D Software

This chapter provides the Sun Expert3D software installation information.

Software Requirements

- Solaris 2.6 Hardware: 3/99, Solaris 7 Hardware: 8/99, Solaris 8 or a subsequent compatible version of the operating environment
- OpenWindows™ Version 3.6, 3.6.1, and 3.6.2
- 1.5 Mbytes of available disk space for Sun Expert3D software
- 42-90 Mbytes of disk space for Sun OpenGL for Solaris (up to 90 Mbytes if 64-bit Sun OpenGL for Solaris is installed)

Note – If your system does not have the Solaris 2.6, Solaris 7, or Solaris 8 operating environment installed, you must install it. Use the text command version of `suninstall` to install the required Solaris operating environment. Refer to the main Solaris installation manuals for this information.

Updated versions of Sun OpenGL for Solaris are available at:

<http://www.sun.com/software/graphics/OpenGL/>

Note – Sun Expert3D graphics card support is included in Solaris 8 software. The Solaris 8 Sun Expert3D software on the CD-ROM contains enhancements and bug fixes that are not present in the Solaris 8 installation.

Sun Expert3D Software Package

Sun Expert3D software is delivered unbundled on a CD-ROM provided with your installation kit.

Software Package Locations

TABLE 3-1 lists the directory locations of the Sun Expert3D software packages.

TABLE 3-1 Location of Sun Expert3D Software Packages

Expert3D Software Packages	Directory Location
Solaris 2.6 software	/cdrom/cdrom0/Expert3D/Solaris_2.6/Product/
Solaris 7 software	/cdrom/cdrom0/Expert3D/Solaris_7/Product/
Solaris 8 software	/cdrom/cdrom0/Expert3D/Solaris_8/Product/

Sun Expert3D Software Package Names

TABLE 3-2 lists the Sun Expert3D software package names and descriptions.

TABLE 3-2 Solaris 2.6, Solaris 7, and Solaris 8 Software Package Names

Package name	Description
SUNWifb.u	64-bit device driver for the PCI Bus Sun Expert3D (IFB) graphics accelerator
SUNWifbcf	Configuration utility for the PCI Bus Sun Expert3D (IFB) graphics accelerator
SUNWifbmn	Manual pages for the PCI Bus Sun Expert3D (IFB) graphics accelerator (not applicable to Solaris 8 operating environment)
SUNWifbr	Boot-time device initialization support for the PCI Bus Sun Expert3D (IFB) graphics accelerator
SUNWifbw	X server loadable module for the PCI Bus Sun Expert3D (IFB) graphics accelerator
SUNWifbx.u	64-bit device driver for the PCI Bus Sun Expert3D (IFB) graphics accelerator (Solaris 7 and Solaris 8 software only)

TABLE 3-2 Solaris 2.6, Solaris 7, and Solaris 8 Software Package Names *(Continued)*

Package name	Description
SUNWifbvt	SunVTS for Sun Expert3D (IFB)
SUNWifbvz	64-bit SunVTS for Sun Expert3D (IFB)

Note – If SunVTS™ is installed in your system, the installation script adds Sun Expert3D to your system VTS framework.

Sun Expert3D Patches

TABLE 3-3 lists the patches for Sun Expert3D software packages.

TABLE 3-3 Sun Expert3D Patches

Solaris release	Patch
Solaris 2.6 software	108788-02
Solaris 7 software	108787-02
Solaris 8 software	108576-03

Sun OpenGL for Solaris Software

The Sun Expert3D graphics card is supported in Sun OpenGL Version 1.1.2 for Solaris, Sun OpenGL Version 1.2 for Solaris, and Sun OpenGL Version 1.2.1 for Solaris operating environments.

Software Package Locations

TABLE 3-4 lists the directory locations of the Sun OpenGL for Solaris software packages.

TABLE 3-4 Location of Sun OpenGL for Solaris Software Packages

Sun OpenGL for Solaris Software Packages	Directory Location
Sun OpenGL 1.1.2 for Solaris, Solaris 2.6 software	/cdrom/cdrom0/OpenGL/1.1.2/Solaris_2.6/Product/
Sun OpenGL 1.1.2 for Solaris, Solaris 7 software	/cdrom/cdrom0/OpenGL/1.1.2/Solaris_7/Product/
Sun OpenGL 1.1.2 for Solaris, Solaris 8 software	/cdrom/cdrom0/OpenGL/1.1.2/Solaris_8/Product/
Sun OpenGL 1.2 for Solaris, Solaris 2.6, Solaris 7, and Solaris 8 software	/cdrom/cdrom0/OpenGL/1.2/Product/
Sun OpenGL 1.2.1 for Solaris, Solaris 2.6, Solaris 7, and Solaris 8 software	/cdrom/cdrom0/OpenGL/1.2.1/Product/

Sun OpenGL for Solaris Software Package Names

TABLE 3-5 lists the Sun OpenGL 1.2.1, 1.2, and 1.1.2 for Solaris software package names and descriptions.

TABLE 3-5 Sun OpenGL Version 1.2.1, 1.2, and 1.1.2 for Solaris Package Names for Solaris 2.6, Solaris 7, and Solaris 8 Software

Package name	Description
SUNWafbg1	Sun OpenGL for Solaris Elite3D support
SUNWafbgx	Sun OpenGL for Solaris 64-bit Elite3D support
SUNWffbg1	Sun OpenGL for Solaris Creator graphics (FFB) support
SUNWffbgx	Sun OpenGL for Solaris 64-bit Creator graphics (FFB) support
SUNWgldoc	Sun OpenGL for Solaris documentation and man pages
SUNWgleg	Sun OpenGL for Solaris utilities and example programs
SUNWglh	Sun OpenGL for Solaris header files
SUNWglrt	Sun OpenGL for Solaris Runtime Libraries
SUNWglrtu	Sun OpenGL for Solaris Platform Specific Runtime Libraries
SUNWglrtx	Sun OpenGL for Solaris 64-bit Runtime Libraries

TABLE 3-5 Sun OpenGL Version 1.2.1, 1.2, and 1.1.2 for Solaris Package Names for Solaris 2.6, Solaris 7, and Solaris 8 Software (*Continued*)

Package name	Description
SUNWifbgl	Sun OpenGL for Solaris Sun Expert3D graphics support
SUNWifbgx	Sun OpenGL for Solaris 64-bit Sun Expert3D graphics support
SUNWglshr	Sun OpenGL for Solaris Runtime Generic Software
SUNWglsrxx	Sun OpenGL for Solaris 64-bit Optimized SW Rasterizer
SUNWglsrz	Sun OpenGL for Solaris Optimized SW Rasterizer

Sun OpenGL for Solaris Patches

TABLE 3-6 lists the Sun OpenGL Version 1.2.1 for Solaris patches required for Solaris 2.6, Solaris 7 and Solaris 8 operating environments.

TABLE 3-6 Sun OpenGL Version 1.2.1 for Solaris Patches

Solaris release	Patch	Directory Location
Solaris 2.6	109543-01	/cdrom/cdrom0/OpenGL/1.2.1/Solaris_2.6/Patches
Solaris 2.6 (64-bit)	109544-01	/cdrom/cdrom0/OpenGL/1.2.1/Solaris_2.6/Patches
Solaris 7	109543-01	/cdrom/cdrom0/OpenGL/1.2.1/Solaris_7/Patches
Solaris 7 (64-bit)	109544-01	/cdrom/cdrom0/OpenGL/1.2.1/Solaris_7/Patches
Solaris 8	109543-01	/cdrom/cdrom0/OpenGL/1.2.1/Solaris_8/Patches
Solaris 8 (64-bit)	109544-01	/cdrom/cdrom0/OpenGL/1.2.1/Solaris_8/Patches

TABLE 3-7 lists the Sun OpenGL Version 1.2 for Solaris patches required for Solaris 2.6, Solaris 7, and Solaris 8 operating environments.

TABLE 3-7 Sun OpenGL Version 1.2 for Solaris Patches

Solaris Release	Patch	Directory Location
Solaris 2.6	108131-10	/cdrom/cdrom0/OpenGL/1.2/Solaris_2.6/Patches
Solaris 2.6 (64-bit)	108132-10	/cdrom/cdrom0/OpenGL/1.2/Solaris_2.6/Patches
Solaris 7	108131-10	/cdrom/cdrom0/OpenGL/1.2/Solaris_7/Patches
Solaris 7 (64-bit)	108132-10	/cdrom/cdrom0/OpenGL/1.2/Solaris_7/Patches
Solaris 8	108131-10	/cdrom/cdrom0/OpenGL/1.2/Solaris_8/Patches
Solaris 8 (64-bit)	108132-10	/cdrom/cdrom0/OpenGL/1.2/Solaris_8/Patches

TABLE 3-8 lists the Sun OpenGL Version 1.1.2 for Solaris patches required for Solaris 2.6, Solaris 7, and Solaris 8 operating environments.

TABLE 3-8 Sun OpenGL Version 1.1.2 for Solaris Patches

Solaris Release	Patch	Directory Location
Solaris 2.6	106735-16	/cdrom/cdrom0/OpenGL/1.1.2/Solaris_2.6/Patches
Solaris 7 (32-bit)	107104-11	/cdrom/cdrom0/OpenGL/1.1.2/Solaris_7/Patches
Solaris 7 (64-bit)	107105-11	/cdrom/cdrom0/OpenGL/1.1.2/Solaris_7/Patches
Solaris 8 (32-bit)	107104-11	/cdrom/cdrom0/OpenGL/1.1.2/Solaris_8/Patches
Solaris 8 (64-bit)	107105-11	/cdrom/cdrom0/OpenGL/1.1.2/Solaris_8/Patches

The Sun Expert3D installation script installs these patches automatically, if required. You can manually install or remove these patches by using `installpatch` and `backoutpatch` for the Solaris 2.6 operating environment, or `patchadd` and `patchrm` for the Solaris 7 and Solaris 8 operating environments.

- To add a patch in the Solaris 2.6 operating environment, type:

```
# installpatch patchnumber
```

- To add a patch in the Solaris 7 and Solaris 8 operating environment, type:

```
# patchadd patchnumber
```

Installing Sun Expert3D Software

Install the Sun Expert3D software from the CD-ROM provided with your installation kit.

1. **After installing the Sun Expert3D card into your system, boot your system at the `ok` prompt:**

```
ok boot -r
```

2. **Log in as superuser.**
3. **Insert the CD-ROM into the drive.**

4. Mount the CD-ROM drive.

- If the drive is already mounted, type the following, and go to Step 5:

```
# cd /cdrom/cdrom0
```

- If the CD-ROM is not already mounted, type:

```
# mount -F hsfs -O -o ro /dev/dsk/c0t6d0s0 /cdrom
# cd /cdrom
```

Note – The CD-ROM device may be different on your system. For example, /dev/dsk/c0t2d0s2.

5. To install the software, as superuser, type:

```
# ./install
```

The following is displayed:

```
# ./install
*** Checking if Sun Expert3D support is already installed...
*** Checking if fbconfig is already installed...
*** Checking if Sun OpenGL is installed...

Select one of the following Sun OpenGL installation options:
1) Install Sun OpenGL 1.1.2
2) Install Sun OpenGL 1.2
3) Install Sun OpenGL 1.2.1
4) Do not install Sun OpenGL
Select an option:
```

The installation program checks if Sun Expert3D software is already installed. If a version of Sun Expert3D software is installed, the program checks to determine the version.

- If a version of Sun Expert3D software is already installed and it is lower than the version you are installing from the CD-ROM, then the program prompts you to confirm an upgrade to the latest release. It then installs the latest version.

- If the same version of Sun Expert3D software is already installed, the program checks that it is fully installed and displays the following:

```
# ./install
*** Checking if Sun Expert3D support is already installed...
*** Checking if fbconfig is already installed...
*** Checking if Sun OpenGL is installed...
*** Checking if Sun OpenGL 1.2 support for Sun Expert3D is installed...

All required software for Sun Expert3D and Sun OpenGL support is already
installed. No software will be installed at this time.
```

- If a higher version of Sun Expert3D software is already installed, the program does not select Sun Expert3D software installation.

The installation program also displays similar prompts when checking for fbconfig and Sun OpenGL for Solaris versions. If Sun OpenGL for Solaris 1.1.2 is fully installed on your system, the program checks for required patches. If no patches are found, the program installs the appropriate patches during the installation process.

6. Select the appropriate Sun OpenGL for Solaris version.

Option 2 is selected for this example:

```
*** Checking if Sun OpenGL 1.2 support for Sun Expert3D is installed...

About to take the following actions:
- Install Sun Expert3D support for Solaris 7
- Install fbconfig
- Install Sun OpenGL 1.2
- Install Sun OpenGL 1.2 support for Sun Expert3D

To cancel installation of this software, press 'q'.
Press any other key to begin installation:
```

7. Press any key and Return to start installation.

Once complete, the following is displayed and the program provides a directory for locating a file log of the installation process. It also provides configuration and reboot instructions.

```
*** Installing Sun Expert3D support for Solaris 7...
*** Installing fbconfig...
*** Installing Sun OpenGL 1.2...
*** Installing Sun OpenGL 1.2 support for Sun Expert3D...
*** Installation complete.
```

To remove this software, use the 'remove' script on this CDROM, or the following script:

```
/var/tmp/expert3d.remove
```

A log of this installation can be found at:

```
/var/tmp/expert3d.install.2000.09.27
```

To configure a Sun Expert3D accelerator, use the fbconfig utility. See the fbconfig(1m) and SUNWifb_config(1m) manual pages for more details.

*** IMPORTANT NOTE! ***

This system must be rebooted for the new software to take effect.

Shutdown the system using the shutdown command and then reboot the system using the 'boot -r' PROM command at the 'ok' prompt. See the shutdown(1M) and boot(1M) manual pages for more details.

8. Shut down the system after Sun Expert3D software is installed:

```
# shutdown
```

See the shutdown(1M) and boot(1M) manual pages for more details.

9. Reboot the system at the ok prompt to complete the installation:

```
ok boot -r
```

Removing Sun Expert3D Software

1. To remove Sun Expert3D software, become superuser and type:

```
# ./remove
```

The following list of options is displayed.

```
# ./remove
1) Remove Sun Expert3D support
2) Remove fbconfig
3) Remove OpenGL
4) Remove All (Sun Expert3D, fbconfig, and OpenGL)
5) Quit
Select an option:
```

2. Select 4 to remove all packages.

The following then is displayed:

```
About to take the following actions:
- Remove Sun Expert3D support
- Remove fbconfig
- Remove OpenGL
Press 'q' to quit, or press any other key to continue:
```

3. Press any key and Return to start the removal process.

Once complete, the following is displayed and the program provides a directory for locating a log of the removal process:

```
*** Removing packages...
*** Done. A log of this removal can be found at:
    /var/tmp/expert3d.remove.2000.09.27
```

Multiple Frame Buffer Configuration

To run more than one frame buffer, you must modify your `/etc/dt/config/Xservers` file. The Sun Expert3D device is identified as `ifbx` (for example, `ifb0` and `ifb1` for two Sun Expert3D devices). To do this:

1. **Become superuser and open the `/etc/dt/config/Xservers` file.**

```
# cd /etc/dt/config
# vi Xservers
```

2. **Modify the file by adding the device locations for the applicable frame buffers being used.**

The following example shows the `Xservers` configuration file modified for one Sun Creator card and two Sun Expert3D cards:

```
:0 Local local_uid@console root /usr/openwin/bin/Xsun :0 -dev /dev/fbs/ffb0
-dev /dev/fbs/ifb1 -dev /dev/fbs/ifb0 -nobanner
```

See “Sun Expert3D Multiview Ports” on page 35 for frame locking multiple Sun Expert3D graphics cards in a single system.

Sun Expert3D as Default Console

To set the Sun Expert3D graphics card as the default monitor console display:

1. **At the `ok` prompt, type:**

```
ok show-displays
```

The following is an example of what is displayed:

```
a) /PCI@@11, 2000/SUNW,Expert3D@1
b) /PCI@@15, 2000/SUNW,afb@1
q) NO SELECTION
```

2. Select the graphics card you want to be the default console display.

In this example, you would select a for the Sun Expert3D card.

3. Set the device you selected to be the console device.

```
ok setenv output-device <Control -Y> <ENTER>
```

4. Reset the output-device environment:

```
ok reset
```

5. Connect your monitor cable to the Sun Expert3D card on your system back panel.

6. Create an alias name for the Sun Expert3D device (optional):

You can simplify future OpenBoot PROM commands by creating an alias for the Sun Expert3D device. To do this,

a. Select the Sun Expert3D device from the `show-displays` menu.

b. Name the Sun Expert3D device (this example names the device as `screen1`).

```
ok nvalias screen1 <Control -Y> <ENTER>
```

c. Store the name as the alias.

```
ok nvstore
```

d. Verify the alias.

```
ok devaliases
```

The selected alias is then displayed.

You can now refer to `screen1` for the Sun Expert3D device. For example,

```
ok setenv output-device screen1
```

Sun Expert3D Man Pages

The Sun Expert3D man pages allow you to query frame buffer attributes such as screen resolutions and visual configurations.

The `fbconfig(1M)` man page is used for configuring Sun graphics accelerators. The `SUNwifb_config(1M)` man page contains Sun Expert3D device-specific configuration information.

Use the `help` option to display the attributes and parameters information of the man page.

- **To access the `fbconfig` man page, type:**

```
# man fbconfig
```

- **To access the `SUNwifb_config` man page, type:**

```
# man SUNwifb_config
```

Changing the Monitor Screen Resolution

For most installations, the Sun Expert3D device automatically configures itself to the proper screen resolution and refresh rate for your monitor. However, if it is not a Sun monitor that is connected to the Sun Expert3D device, the monitor may have the wrong screen resolution. To change the screen resolution, use the `fbconfig` and `SUNwifb_config` utilities.

Sun Expert3D Graphics Card Features and Specifications

This appendix provides features and specifications for the Sun Expert3D graphics accelerator. It also describes how to configure multiple Sun Expert3D cards in a single system.

Sun Expert3D Graphics Card Features

- Geometry acceleration
 - Model view matrix transformation of vertex and normal coordinates
 - Texture matrix transformation of texture coordinates
 - Full lighting calculations with up to 24 light sources
 - Up to six user clip planes
 - Perspective transformation
 - Viewport transformation
 - View volume clipping
 - Image processing

- OpenGL operations
 - Points (2D, 3D, wide)
 - Vectors (2D and 3D lines and line strips; wide, stippled)
 - Polygons (triangles, triangle strips, quads, quad strips, polygons, point/line polygon mode)
 - Antialiased points, vectors, and polygons
 - Image support (multiple formats, zoom, bilinear scaling, color matrix, color tables)
 - Alpha operations
 - Scissoring
 - Window clipping
 - Masking
 - Fogging (linear, exponential, exponential², user-defined)
 - Texture mapping (point, bilinear, trilinear, multiple internal formats)
 - Stencil operations
 - Dithering
 - Rich set of blending operations
 - Fast window clears
 - Fast window-mode double buffering
 - Frame-sequential stereo support
- Extensive support of OpenGL extensions
 - Imaging extensions such as pixel buffer, color table, color matrix, and convolution
 - Blend extensions such as blend color, blend minmax, and blend function separate
 - Texture extensions (edge clamp, border clamp, LOD clamp, generate mipmap)
 - Texture color table
 - Post-texturing specular
 - Stencil operation wrap

Additional Sun Expert3D Features

- 8 Mbytes of SDRAM DirectBurst memory
- 64 Mbytes onboard SDRAM texture memory with full mipmapped trilinear interpolated texture processing
- 64 Mbytes of frame buffer SDRAM memory
- 10-bit gamma correction
- Hardware cursor
- Stereoscopic viewing support (interlaced or frame sequential)
- Display Data Channel (DDC) monitor support for bidirectional communication
- Display Power Management Signaling (DPMS) to enable monitor's power-saving mode
- High-speed, full-featured DMA over the PCI-64 bus
- Multiscreen support using multiple cards in a single workstation
- Frame locking of the video timing to an external timing source
- Multiview functionality for frame locking and rate locking of multiple workstations
- Two video lookup tables

Sun Expert3D Specifications

The Sun Expert3D graphics accelerator is a full-length PCI graphics card with internal I/O ports for multiviewing and external I/O ports for external video synchronization and stereo capabilities.

Internal I/O Ports

The internal I/O ports (Multiview-In and Multiview-Out) are accessible only inside the workstation chassis and are used for cable connections from one Sun Expert3D card to another. See “Sun Expert3D Multiview Ports” on page 35.

External I/O Ports

The external I/O ports are accessible through the I/O connectors on the Sun Expert3D card backplate (FIGURE A-1).

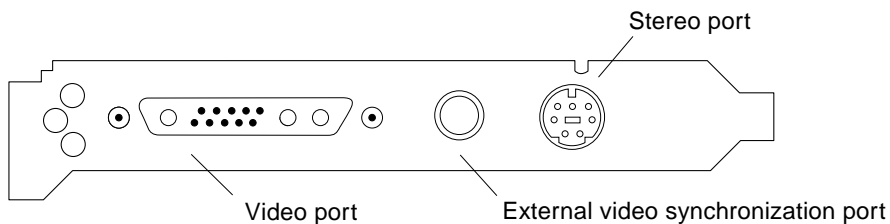

FIGURE A-1 Sun Expert3D Connectors

The Sun Expert3D graphics card has the following external I/O ports:

- Video output port
- Stereo output port
- External video synchronization port

Video Output Port

The video output port is a 13W3 connector that connects the workstation monitor.

TABLE A-1 Sun Expert3D Video Output Port

Pin	Signal
A1	Red analog video
A2	Green analog video
A3	Blue analog video
1	DDC SCL (serial clock)
2	DDC power (5.0V) (Fused, will supply up to 300mA, limited to 1.0A.)
3	No connection
4	Ground (DDC return)
5	Composite sync
6	DDC SDA (serial data)
7	Vertical sync
8	No connection
9	No connection
10	Ground (sync return)

Stereo Output Port

FIGURE A-2 and TABLE A-2 shows the Sun Expert3D stereo connector and pinout signals.

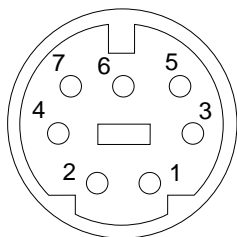

FIGURE A-2 Sun Expert3D 7-Pin DIN Female Stereo Connector

TABLE A-2 Sun Expert3D Stereo Output Port

Pin	Signal
1	Ground
2	5.0V (Fused, will supply up to 300mA, limited to 1.0A.)
3	12.0V (Fused, will supply up to 300mA, limited to 1.0A.)
4	Stereo sync
5	No connection
6	No connection
7	No connection

External Video Synchronization Port

The external video synchronization port uses a 75-Ohm BNC male connector. A 75-Ohm coax cable terminated with a female BNC connector is needed to connect to this port and provide a periodic signal to which the display system attempts to lock its vertical refresh rate.

The supported formats are:

- NTSC composite video
- PAL composite video
- TTL, LVTTTL, or CMOS level compatible periodic signal (50 Hz–180 Hz), with a minimum low or high pulse or 100ns (TBV)

Sun Expert3D Multiview Ports

The Multiview-In and Multiview-Out ports use a polarized 10-pin dual-in-line header. These ports allow frame locking and rate locking of multiple Sun Expert3D cards in a single workstation in order to display synchronous multiscreen applications. Cards are daisy-chained together, using the multiview cable supplied in the Sun Expert3D x-option kit, by connecting the Multiview-Out port of one card to the Multiview-In port, and is designated as the master card. The last card in the chain has no connection to the Multiview-Out port.

TABLE A-3 Sun Expert3D Multiview-In Port and Multiview-Out Port Pinout

Pin	Multiview-In port pinout signal	Multiview-Out port pinout signal
1	Ground	Ground
2	Done Output	Done Input
3	Ground	Ground
4	Release Input	Release Output
5	Ground	Ground
6	Sense Input	Sense Loopback
7	Ground	Ground
8	Ground	Sense Loopback
9	Ground	Ground
10	Pixel Align Input	Pixel Align Output

Frame Locking Multiple Sun Expert3D Graphics Cards

You can frame lock only two Sun Expert3D graphics cards for multiviewing in Ultra 60 and Ultra 80 systems.

- When rebooting your system after installing the Sun Expert3D software, the Solaris operating environment places *all* Sun Expert3D cards in the system in master mode. Use `fbconfig` to set the slave Sun Expert3D cards.
- There can only be *one* master Sun Expert3D card in a system.
- You must choose a resolution supported by Sun Expert3D and assure that each Sun Expert3D monitor in frame lock is set to that resolution.

- Refer to the `boot -r` man page for device location and device numbering information for how devices are numbered based on their physical location. You may select any device (that is, `ifb0` or `ifb1`) to be the master Sun Expert3D device.
- To configure multiple Sun Expert3D cards for multiviewing through frame locking:

1. Select a Sun Expert3D card to designate as master for the Sun Expert3D graphics cards.

One solution for designating a Sun Expert3D to be the master is to use the Sun Expert3D that serves as the boot/console head for that system.

2. Make sure that each Sun Expert3D installed has the same monitor resolution as the Sun Expert3D in master mode.

If the resolution on each Sun Expert3D graphics card is not the same, you must change it to match the Sun Expert3D card in master mode.

- a. To check the resolution of a Sun Expert3D card, use the `fbconfig` command. For example:**

```
% fbconfig -dev /dev/fbs/ifb0 -prconf
```

- b. You must repeat this command for each Sun Expert3D card in the system.**

The `fbconfig` command displays the current monitor resolution setting. It also displays additional information such as whether the Sun Expert3D card is a master or slave.

- c. If you need to change the resolution of a Sun Expert3D card, use the `fbconfig` command. For example:**

```
% fbconfig -dev /dev/fbs/ifb1 -res 1280x1024x76 now nocheck
```

3. **Connect the frame lock multiview cable to each Sun Expert3D graphics card (FIGURE A-3).**
 - a. **Connect the top of the multiview frame lock cable assembly to the multiview-out J2 connector of the master Sun Expert3D card.**
 - b. **Connect the other end of the multiview frame lock cable to the multiview-in J1 connector of the slave Sun Expert3D card.**

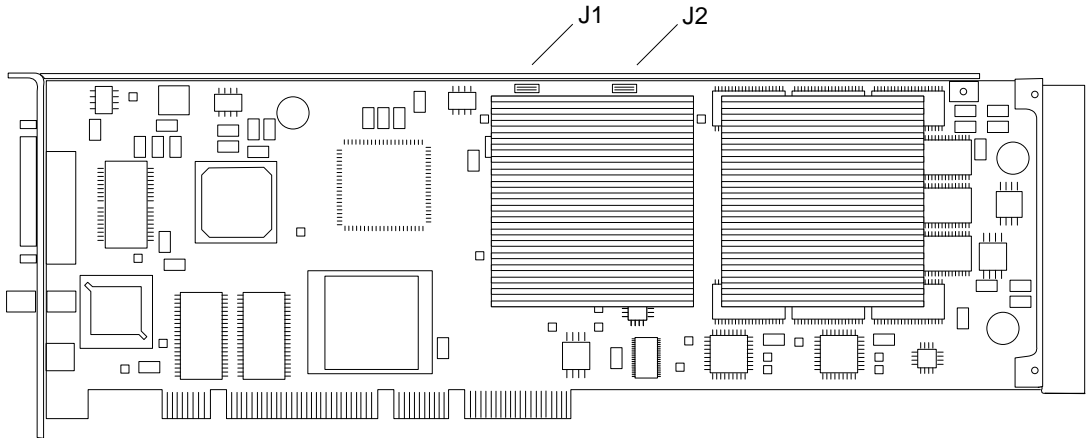

FIGURE A-3 Sun Expert3D Multiview-In and Multiview-Out Connectors

4. **From the master Sun Expert3D graphics card display window, configure the other Sun Expert3D graphics card in slave mode.**

To do this, use the `fbconfig` command.

```
% fbconfig -dev /dev/fbs/ifb1 -slave on
```

You must configure each card separately.

In order to reconfigure your Sun Expert3D graphics card from slave mode back to master mode, do one of the following:

- Power cycle the system.
- Use the `fbconfig` command. For example:

```
% fbconfig -dev /dev/fbs/ifb1 -slave off
```

You must configure each card in slave mode separately.

Your system is now ready for frame lock and buffer swap synchronization software applications.

Sun Expert3D Screen Resolutions and Video Formats

TABLE A-4 lists the monitor screen resolutions and video formats supported by the Sun Expert3D graphics accelerator:

TABLE A-4 Sun Expert3D Monitor Resolutions

Display resolution	Vertical refresh rate	Sync standard	Aspect ratio format
1920 x 1200	70, 75 Hz	Sun	16:10
1920 x 1080	72 Hz	Sun	16:9
1792 x 1344	75 Hz	VESA	4:3
1600 x 1280	76 Hz	Sun	5:4
1600 x 1200	75 Hz	VESA	4:3
1600 x 1000	66, 76 Hz	Sun	16:10
1440 x 900	76 Hz	Sun	16:10
1280 x 800	112 Hz	Sun-Stereo	16:10
1280 x 800	76 Hz	Sun	16:10
1280 x 1024	60, 75, 85 Hz	VESA	5:4
1280 x 1024	67, 76 Hz	Sun	5:4
1280 x 1024	112 Hz	Sun-Stereo	5:4
1152 x 900	66, 76 Hz	Sun	5:4
1024 x 800	84 Hz	Sun	5:4
1024 x 768	75 Hz	VESA	4:3
1024 x 768	60, 70, 77 Hz	Sun	4:3
960 x 680	108, 112 Hz	Sun-Stereo	Sun-Stereo
768 x 575	50i Hz	PAL	PAL
640 x 480	60 Hz	VESA	4:3
640 x 480	60i Hz	NTSC	NTSC